

MXV-B

Vertical Multi-Stage Close Coupled Pumps



The electropumps MXV-B.. series comply with the European Regulation no. 547/2012.

Construction

Vertical multi-stage close coupled pumps with suction and delivery connections of the same diameter and arranged along the same axis (in-line).

All parts that come into contact with the liquid, are in chrome-nickel stainless steel with corrosion-resistant bearing sleeves lubricated by the pumped liquid.

Version with frequency converter (on request)

Applications

For water supply systems.

For clean non-explosive liquids, without solid, filamentary or abrasive matter and non-aggressive for stainless steel (with adaptation of sealing materials on request).

A universal pump for civil and industrial use, for pressure-boosting systems, high-pressure washing plants, irrigation, agricultural uses and sport installations.

Operating conditions

Temperature of liquid: from -15 °C to +90 °C.

Operating environment temperature: up to 40 °C.

Maximum permissible pressure in pump casing: 16 bar.

Continuous duty.

Motor

2-pole induction motor, 50 Hz ($n \approx 2900$ rpm).

MXV-B: three-phase 230/400 V $\pm 10\%$ up to 3 kW;
400/690 V $\pm 10\%$ from 3,7 kW.

MXV-BM: single-phase 230 V $\pm 10\%$, with thermal protector.
Capacitor inside the terminal box.

Insulation class F.

Protection IP 54.

Three-phase motor suitable for operation with frequency converter.

IE3 efficiency class for three-phase motors.

Constructed in accordance with: EN 60034-1, EN 60034-30-1.
EN 60335-1, EN 60335-2-41.

Materials (wetted parts)

Component	Material
External jacket	Chrome-nickel steel 1.4301 EN 10088 (AISI 304)
Suction casing	
Delivery casing	
Stage casing	
Impeller	
Lower cover	
Upper cover	
Spacer sleeve	Cr-Ni steel 1.4301 EN 10088 (AISI 304)
Pump shaft	
Plug	Cr-Ni steel 1.4301 EN 10088 (AISI 304)
Mechanical seal ISO 3069 - KU	Ceramic alumina/Carbon/EPDM
Wear ring	PTFE
O-ring	NBR
Oval Counterflanges	Cr-Ni steel 1.4301 EN 10088 (AISI 304)

Special features on request

- Other voltages.
- Frequency 60 Hz.
- Protection IP 55.
- Special mechanical seal
- Pump casing seal rings in FPM.
- Higher or lower liquid or ambient temperatures.

Designation

Series MXV-B M EI 25 - 305 O

Single-phase motor (up to 2.2 kW) _____

With frequency converter I-MAT _____

DN ports in mm _____

Rated capacity in m³/h _____

Number of stages _____

Oval Flanges _____

Coverage chart $n \approx 2900$ rpm

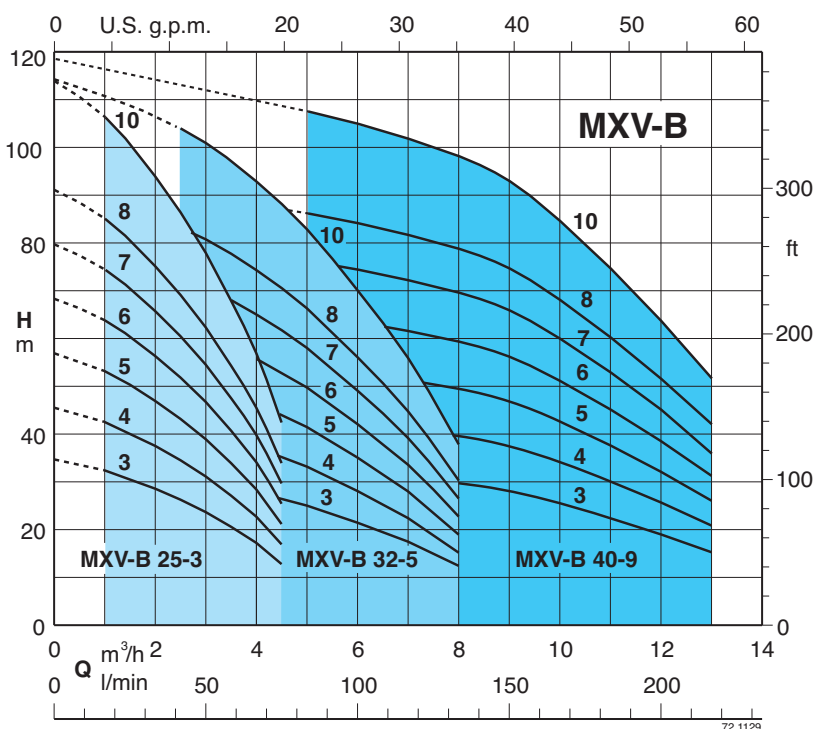

Pumps with frequency converter

The **MXV-B EI** pumps are available with power from 0,75 kW up to 3,7 kW, the pumps are equipped with **I-MAT** installed on board which allows to realize a variable-speed system extremely compact and efficient, ideal in applications of water supply and in the distribution of hot and cold water. The pump is equipped with transducers suitable for operation and is already programmed at the factory.

Advantages

- Energy saving
- Compact design
- Easy to use
- Programmable to suit the system requirements
- Reliability

Costruction

The system comprises of:

- Pump
- Induction motor
- I-MAT Frequency converter
- Motor adapter for the motor mounting of the frequency converter
- Connection cable between frequency converter and induction motor
- Transducers

Main features

- Rated motor power output from 0,75 kW to 3,7 kW
- Control range from 1750 to 2900 rpm (2-pole)
- Protection against dry running
- Protection against operations with closed connection ports
- Protection against system leakages
- Protection against overcurrent in the motor
- Protection against overvoltage and undervoltage of the power supply
- Protection against current unbalances between phases



Operating modes



Constant pressure mode with pressure transducer

In this mode, the system maintains the preset pressure when the flow required by the installation changes.

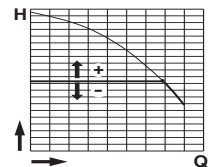

Proportional pressure mode with pressure transducer

In this mode the system changes the working pressure according to the required flow rate.

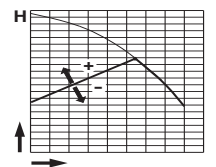

Constant flow mode with flow meter

In this mode the system maintains a constant flow rate value in a point of the installation according to the required pressure.

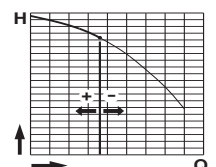

Fixed speed mode with setting of the speed preferential rotation.

In this mode, by changing the working frequency, you may choose any operational curve included within the working range.

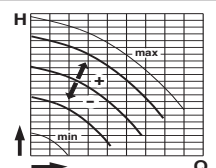

Constant temperature mode with temperature transducer

In this mode the system keeps the temperature constant inside a system by changing the speed of the pump.

Characteristic curves and performance $n \approx 2900$ rpm

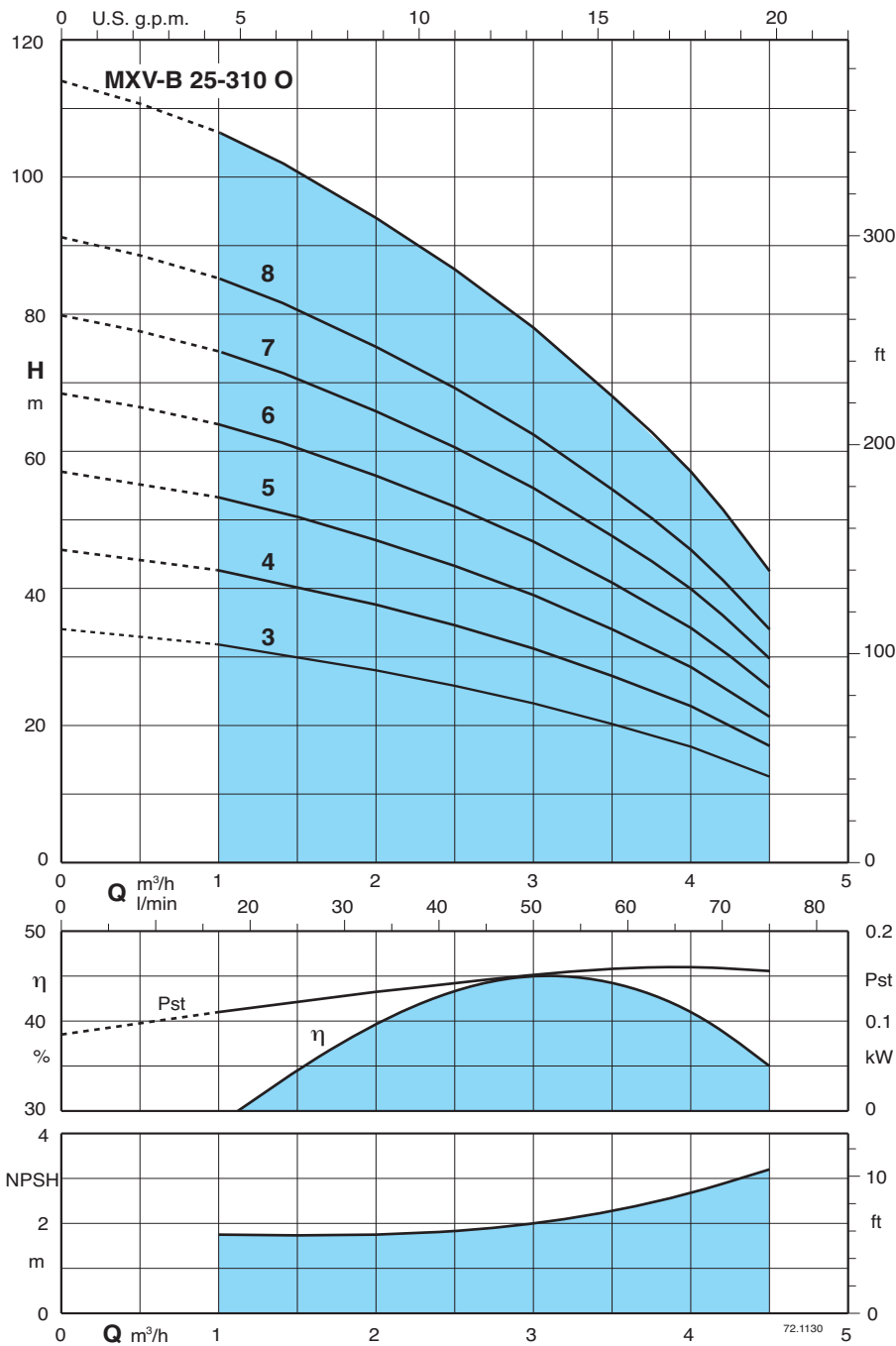

Test results with clean cold water, without gas content.
 A safety margin of + 0.5 m is recommended for the NPSH value.
 Tolerances in accordance with UNI EN ISO 9906:2012

Head and power values valid for liquids with density $\rho = 1,0 \text{ kg/dm}^3$ and kinematic viscosity $\nu = \text{max } 20 \text{ mm}^2/\text{sec}$.

Pst = Power with reference to one stage.
 P1 Max. power input.
 P2 Rated motor power output.

3 ~	230 V 400 V		1 ~	230 V P1		P2		m³/h Q l/min	H								
	A	A		A	kW	kW	HP		0	1	1,5	2	2,5	3	3,5	4	4,5
MXV-B 25-303 O	4	2,3	MXV-BM 25-303 O	5,8	1,1	0,75	1	0	0	16,6	25	33,3	41,6	50	58,3	66,6	75
MXV-B 25-304 O	4	2,3	MXV-BM 25-304 O	5,8	1,1	0,75	1	34	32	30	28	26	23,5	20,5	17	12,5	
MXV-B 25-305 O	4	2,3	MXV-BM 25-305 O	5,8	1,1	0,75	1	44	42,5	40	37,5	34,5	31	27	22,5	17	
MXV-B 25-306 O	4,7	2,7	MXV-BM 25-306 O	7,4	1,5	1,1	1,5	56	53	50	47	43	39	34	28	21	
MXV-B 25-307 O	4,7	2,7	MXV-BM 25-307 O	7,4	1,6	1,1	1,5	68	63,5	60,5	56	51,5	46,5	40,5	34	25	
MXV-B 25-308 O	7,5	4,3	MXV-BM 25-308 O	9,2	2	1,5	2	79,5	74	70,5	65,5	60	54,5	47,5	39,5	30	
MXV-B 25-310 O	7,5	4,3	MXV-BM 25-310 O	9,2	2,3	1,5	2	91	85	80,5	75	69	62	54	45,5	34	
								114	106	101	94	86	78	68	57	42	

Characteristic curves and performance $n \approx 2900$ rpm

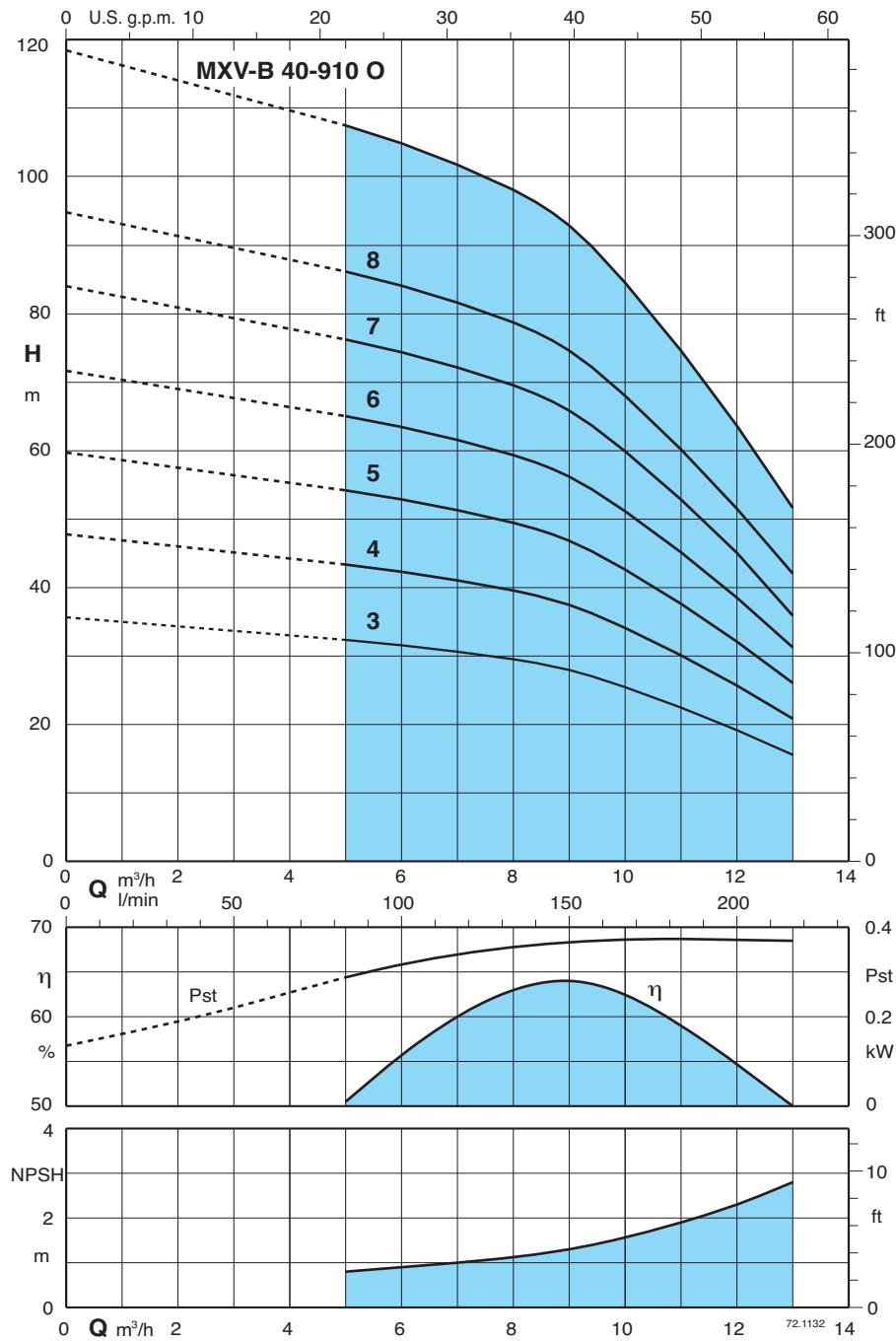

Test results with clean cold water, without gas content.
 A safety margin of + 0.5 m is recommended for the NPSH value.
 Tolerances in accordance with UNI EN ISO 9906:2012

Head and power values valid for liquids with density $\rho = 1,0 \text{ kg/dm}^3$ and kinematic viscosity $\nu = \text{max } 20 \text{ mm}^2/\text{sec}$.

Pst = Power with reference to one stage.
 P1 Max. power input.
 P2 Rated motor power output.

3 ~	230 V 400 V		1 ~	230 V P1		P2		m³/h Q l/min	H m												
	A	A		A	kW	kW	HP		0	5	6	7	8	9	10	11	12	13			
MXV-B 40-903 O	4,7	2,7	MXV-BM 40-903 O	7,4	1,6	1,1	1,5	0	83,3	100	116,6	133,3	150	166,6	183,3	200	216,6				
MXV-B 40-904 O	7,5	4,3	MXV-BM 40-904 O	9,2	2,3	1,5	2	35,5	32,5	31,5	31	29,5	28	25,5	22,5	19,5	15,5				
MXV-B 40-905 O	9,15	5,3				2,2	3	47	43	42	41	40	37	34	30	26	21				
MXV-B 40-906 O	9,15	5,3				2,2	3	59	54	53	51	50	47	43	38	32	26				
MXV-B 40-907 O	11,5	6,6				3	4	71	65	63	62	59	56	51	45	39	31				
MXV-B 40-908 O	11,5	6,6				3	4	83	76	74	72	69	66	60	53	45	36				
MXV-B 40-910 O		9,6				3,7	5	95	87	85	82	79	75	69	60	51	42				
								119	109	106	103	99	94	86	75	64	52				

Dimensions and weights

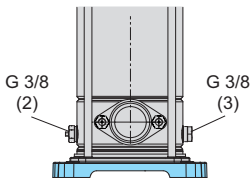

Oval Counterflanges

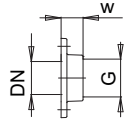

PN 16

DN	G	w	Holes	
			N.	Ø
25	1	23	2	12
32	1 1/4	23	2	12
40	1 1/2	26	2	15

Oval Flanges

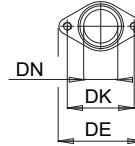

PN 16

DN	DE	DK	Holes	
			N.	Ø
25	95	75	2	M10
32	95	75	2	M10
40	125	100	2	M12

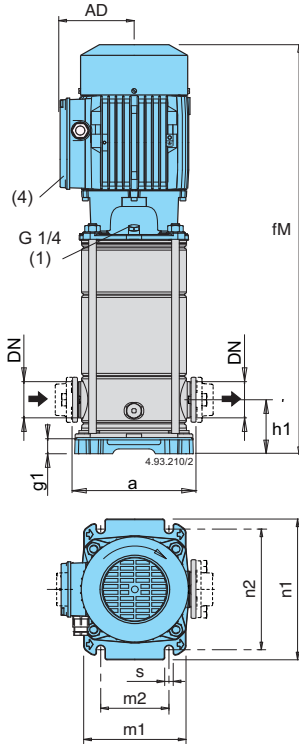

Pump	Motor P ₂		mm										
	kW	HP	DN	a	h1	fM	AD	n1	n2	m1	m2	s	g1
MXV-B(M) 25-303 O	0,75	1	25	160	50	553	128	205	180	165	100	13	20
MXV-B(M) 25-304 O	0,75	1	25	160	50	553	128	205	180	165	100	13	20
MXV-B(M) 25-305 O	0,75	1	25	160	50	577	128	205	180	165	100	13	20
MXV-B(M) 25-306 O	1,1	1,5	25	160	50	601	128	205	180	165	100	13	20
MXV-B(M) 25-307 O	1,1	1,5	25	160	50	625	128	205	180	165	100	13	20
MXV-B(M) 25-308 O	1,5	2	25	160	50	649	128	205	180	165	100	13	20
MXV-B(M) 25-310 O	1,5	2	25	160	50	697	128	205	180	165	100	13	20
MXV-B(M) 32-503 O	0,75	1	32	160	50	553	128	205	180	165	100	13	20
MXV-B(M) 32-504 O	1,1	1,5	32	160	50	553	128	205	180	165	100	13	20
MXV-B(M) 32-505 O	1,1	1,5	32	160	50	577	128	205	180	165	100	13	20
MXV-B(M) 32-506 O	1,5	2	32	160	50	601	128	205	180	165	100	13	20
MXV-B(M) 32-507 O	1,5	2	32	160	50	625	128	205	180	165	100	13	20
MXV-B 32-508 O	2,2	3	32	160	50	689	128	205	180	165	100	13	20
MXV-B 32-510 O	2,2	3	32	160	50	737	128	205	180	165	100	13	20
MXV-B(M) 40-903 O	1,1	1,5	40	200	80	601	128	250	215	190	130	14	30,5
MXV-B(M) 40-904 O	1,5	2	40	200	80	601	128	250	215	190	130	14	30,5
MXV-B 40-905 O	2,2	3	40	200	80	631	128	250	215	190	130	14	30,5
MXV-B 40-906 O	2,2	3	40	200	80	701	128	250	215	190	130	14	30,5
MXV-B 40-907 O	3	4	40	200	80	755	138	250	215	190	130	14	30,5
MXV-B 40-908 O	3	4	40	200	80	789	138	250	215	190	130	14	30,5
MXV-B 40-910 O	3,7	5	40	200	80	849	138	250	215	190	130	14	30,5

- (1) Filling
- (2) Air vent suction side
- (3) Draining
- (3) Standard position of terminal box

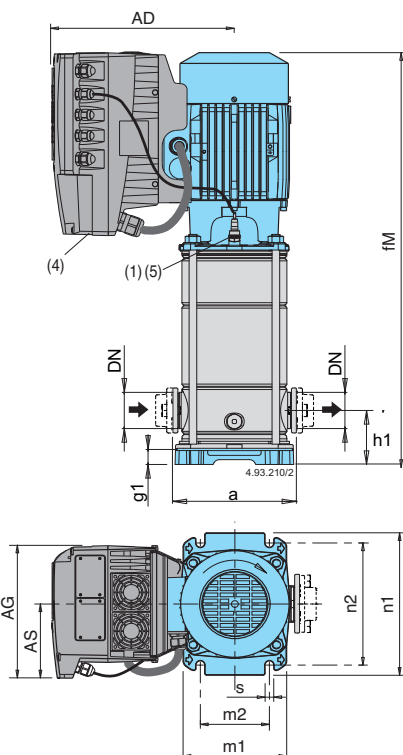

Pump	Motor P ₂		mm												
	kW	HP	DN	a	h1	fM	AD	AG	AS	n1	n2	m1	m2	s	g1
MXV-B EI 25-303 O	0,75	1	25	160	50	553	286	190	105	205	180	165	100	13	20
MXV-B EI 25-304 O	0,75	1	25	160	50	553	286	190	105	205	180	165	100	13	20
MXV-B EI 25-305 O	0,75	1	25	160	50	577	286	190	105	205	180	165	100	13	20
MXV-B EI 25-306 O	1,1	1,5	25	160	50	601	286	190	105	205	180	165	100	13	20
MXV-B EI 25-307 O	1,1	1,5	25	160	50	625	286	190	105	205	180	165	100	13	20
MXV-B EI 25-308 O	1,5	2	25	160	50	649	286	190	105	205	180	165	100	13	20
MXV-B EI 25-310 O	1,5	2	25	160	50	697	286	190	105	205	180	165	100	13	20
MXV-B EI 32-503 O	0,75	1	32	160	50	553	286	190	105	205	180	165	100	13	20
MXV-B EI 32-504 O	1,1	1,5	32	160	50	553	286	190	105	205	180	165	100	13	20
MXV-B EI 32-505 O	1,1	1,5	32	160	50	577	286	190	105	205	180	165	100	13	20
MXV-B EI 32-506 O	1,5	2	32	160	50	601	286	190	105	205	180	165	100	13	20
MXV-B EI 32-507 O	1,5	2	32	160	50	625	286	190	105	205	180	165	100	13	20
MXV-B EI 32-508 O	2,2	3	32	160	50	689	286	210	118	205	180	165	100	13	20
MXV-B EI 32-510 O	2,2	3	32	160	50	737	286	210	118	205	180	165	100	13	20
MXV-B EI 40-903 O	1,1	1,5	40	200	80	601	286	190	105	250	215	190	130	14	30,5
MXV-B EI 40-904 O	1,5	2	40	200	80	601	286	190	105	250	215	190	130	14	30,5
MXV-B EI 40-905 O	2,2	3	40	200	80	631	286	210	118	250	215	190	130	14	30,5
MXV-B EI 40-906 O	2,2	3	40	200	80	701	286	210	118	250	215	190	130	14	30,5
MXV-B EI 40-907 O	3	4	40	200	80	755	294	210	118	250	215	190	130	14	30,5
MXV-B EI 40-908 O	3	4	40	200	80	789	294	210	118	250	215	190	130	14	30,5
MXV-B EI 40-910 O	3,7	5	40	200	80	849	294	210	118	250	215	190	130	14	30,5

- (1) Filling
- (2) Air vent suction side
- (3) Draining
- (4) Standard position of I-MAT
- (5) Pressure transducer

Features

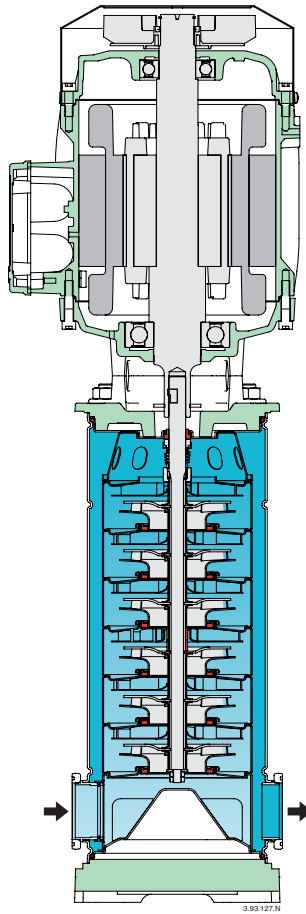

Wider Range of Application

All parts that come into contact with the liquid, including wet-end covers, are in chrome-nickel stainless steel.

With corrosion-resistant seal rings and guide ring.

Low Cost Installation

Vertical construction with reduced pump height for installation in small spaces.

In-line connections to simplify the piping layout with the possibility of inserting the pump in straight pipe-lines.

Disassembly, inspection or cleaning of internal parts without removal of piping.

Robust and Reliable

The suction and discharge nozzles arranged in-line absorb the forces of the piping on the pump without the creation of distorting loads causing local friction and early wears.

The lantern brackets compact and robust design maintains a sure alignment between rotating and fixed parts, reducing vibration.

The upper cover design prevents entrapment of air around the mechanical seal.

Low-Noise Operation

The water filled shroud around the stages and thick external walls, work together for low-noise operation.