



Construction

5" Close coupled multi-stage submersible pumps. Easy to install, compact and plug and play with integrated pressure transducer for automatic control of starting/stopping of the pump when utilization points are opened/closed with a integrated non-return valve.

External jacket in stainless steel AISI 304 and stages Noryl. E-MPSM with built-in capacitor, accessible through the delivery casing.

Hydraulics located below the motor with the motor cooled by the pumped fluid. Safe operation is possible with the motor only partially submerged.

Double shaft seal with oil chamber.

The suction strainer prevents the entrance of solids with diameter bigger than 2 mm.

Applications

For water supply from wells, tanks or reservoirs.

For domestic, civil and industrial applications, for garden use, irrigation and rain water harvesting systems.

Features

- high efficiency asynchronous single-phase motor
- capacitor less stressed in voltage
- uniform and lower motor temperature
- motor power control
- programmable re-start pressure
- programmable stop pressure
- no hydraulic losses due to the measuring devices
- voltage and current control
- monitoring of maximum starting current

Protections

- dry-run protection
- overload control and overheating motor control
- pump blockage
- power supply control
- starts per hour control

Operating conditions

Water temperature up to 35 °C.

Minimum internal diameter of well: 140 mm.

Minimum immersion depth: 100 mm.

Maximum immersion depth: 20 m (with suitable cable length).

Continuous duty.

Motor

2-pole induction motor, 50 Hz ($n \approx 2800$ rpm).

Single-phase 230 V \pm 10%, with thermal protector.

Incorporated capacitor.

Cable: - Pump 07BB-F, 3G1+4x0,34 mm², length 23 m.

- Power supply cable H07RN8-F, 3G1,5 length 1,5 m with plug CEI-UNEL 47166.

Insulation class F.

Protection IP X8 (for continuous immersion).

Triple impregnation humidity-proof dry winding.

Constructed in accordance with EN 60335-2-41.



EASY TO INSTALL
Plug And Play solution



ECONOMIC SAVING
High efficiency asynchronous single-phase motor
24 % less energy consumption compared to a standard pump

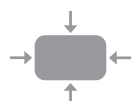

EASY TO USE
Equipped with a programmable software and, thanks to the analogic pressure sensor, the product allows to set the restart pressure. An ideal solution which allows to reduce or remove the need of an expansion tank

Materials

Component	Material
Delivery casing External jacket Suction strainer Motor jacket	Chrome-nickel steel 1.4301 EN 10088 (AISI 304)
Non-return valve	POM - POLYACETAL
Stage casing Impeller	PPO-GF20 (Noryl)
Shaft	Chrome-nickel steel 1.4301 EN 10088 (AISI 304)
Capacitor cover Oil chamber cover Preload ring stages Support ring preload	PPS Polymer (Grivory)
Upper mechanical seal Lower mechanical seal	Steatite, carbon, NBR Carbon, silicon carbide, NBR
Seal lubrication oil	Oil for food machinery and pharmaceutical use

Performance $n \approx 2800$ 1/min

1 ~	230 V			Capacitor		P ₁ kW	P ₂		Q m ³ /h l/min	0	1	1,5	2	2,5	3	3,5	4	4,5	
	A	μ F	V	kW	kW		HP	0		16,6	25	33,3	41,6	50	58,3	66,6	75		
E-MPSM 304	4,1	25	450	0,8	0,55	0,75	H m	44	40	37,5	35	31,5	28,5	24,5	21	16			
E-MPSM 305	5	30	450	1	0,75	1		56	50	47	44	40	36	32	26,5	21,5			
E-MPSM 306	6	35	450	1,2	0,9	1,2		66,5	60,5	57	53	48,5	43,5	38	32	26			

1 ~	230 V			Capacitor		P ₁ kW	P ₂		Q m ³ /h l/min	0	2,5	3	3,5	4	4,5	5	6	7	8
	A	μ F	V	kW	kW		HP	0		41,6	50	58,3	66,6	75	83,3	100	116	133	
E-MPSM 504	6	35	450	1,2	0,9	1,2	H m	45	39,5	37,8	35,8	33,5	31	28	22	15,5	8		
E-MPSM 505	7	35	450	1,3	1,1	1,5		53	47,5	45,5	43	40	37	33	26	18	10		

P1 Max. power input. P2 Rated motor power output. Tolerances according to UNI EN ISO 9906:2012 Test results with clean cold water, without gas content.

Dimensions and weights

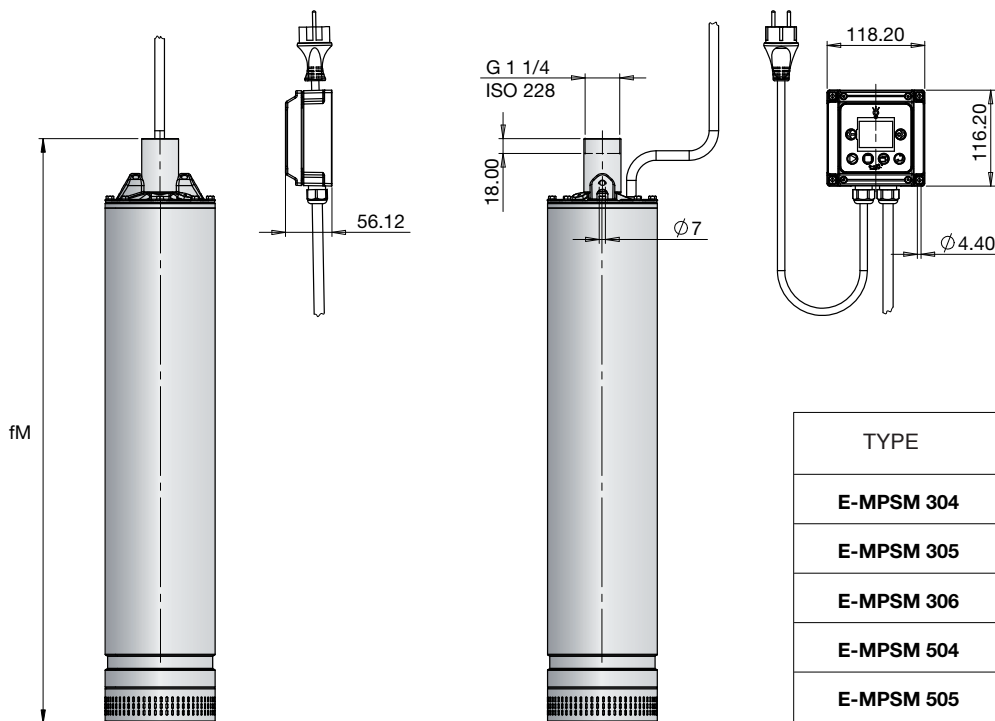

TYPE	fM mm	Net weight kg ¹⁾
E-MPSM 304	659.2	15.5
E-MPSM 305	708.2	16.9
E-MPSM 306	732.2	17.8
E-MPSM 504	684.2	17.1
E-MPSM 505	708.2	17.4

¹⁾ With cable length: 23 m

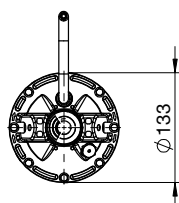

Characteristic curves $n \approx 2800$ 1/min

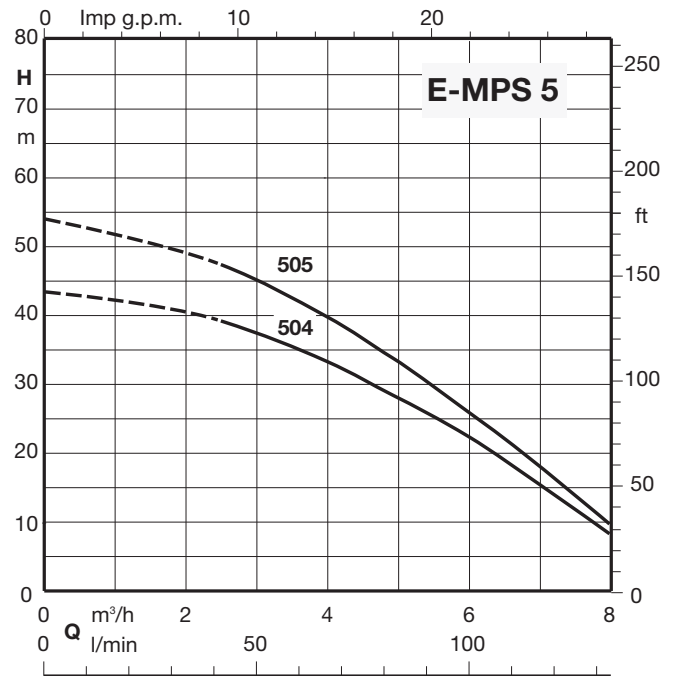
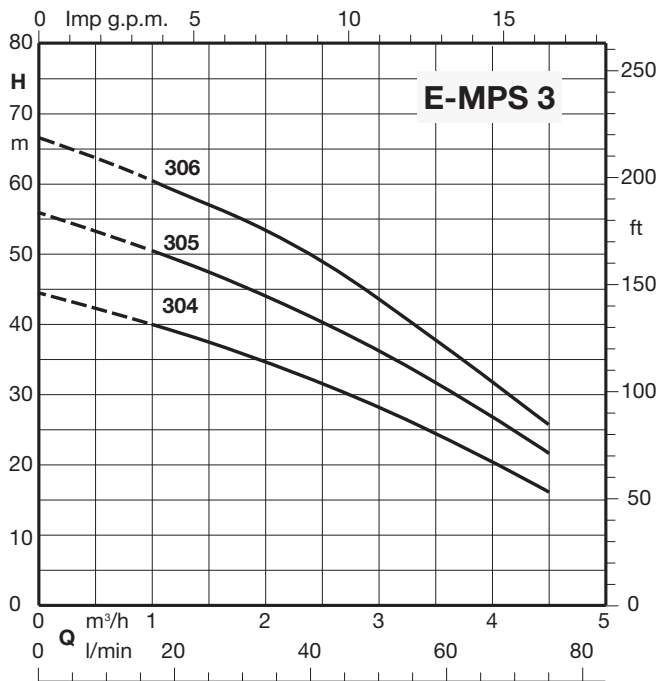

Installation

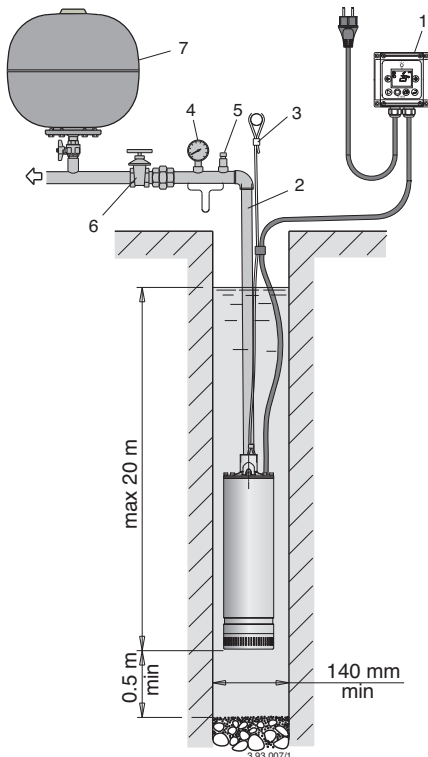

Pump in the suspended position

1. Control box
2. Delivery pipe
3. Safety rope
4. Pressure gauge
5. Air vent valve
6. Gate valve
7. Pressure tank

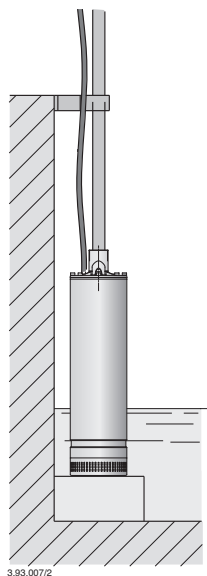

Pump in the standing position

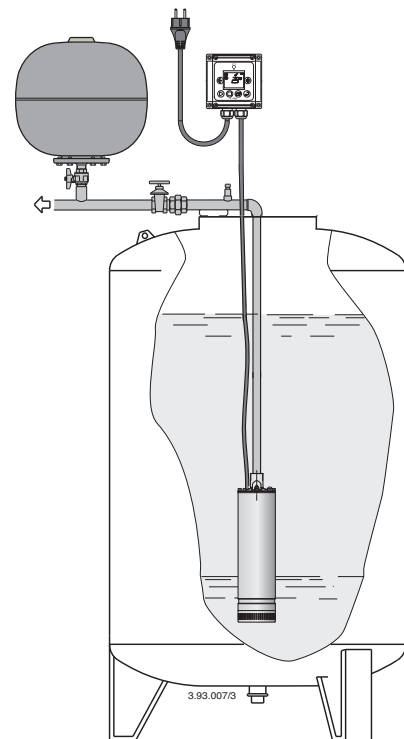

Installation examples