



Data sheet

Hydraulic data

Minimum efficiency index (MEI)	≥0.7
Maximum operating pressure P_N	16 bar
Min. fluid temperature T_{min}	-20 °C
Max. fluid temperature T_{max}	140 °C
Min. ambient temperature T_{min}	0 °C
Max. ambient temperature T_{max}	50 °C

Drive

Mains connection	3~400 V, 50/60 Hz
Number of poles	4
Motor efficiency class	IE5
Power consumption $P_{1 max}$	3300 W
Rated power P_2	3 kW
Max current I_{max}	5.1 A
Emitted interference	EN 61800-3
Interference resistance	EN 61800-3
Insulation class	F
Protection class motor	IP55
Motor protection	PTC integrated

Materials

Pump housing	Grey cast iron
Impeller	PPS-GF40
Shaft	Stainless steel
Shaft seal	AQ1EGG
Lantern	5.1301/EN-GJL-250 KTL-coated

Approved liquids (other liquids upon request)

Heating water (as per VDI 2035)	yes
Heat carrier oil	Special version at additional charge
Cooling and cold water circulation systems	yes
Water-glycol mixtures (at 20 – 40 vol. % glycol and fluid temperature ≤ 40 °C)	yes

Installation dimensions

Port-to-port length L_0	360 mm
Pipe connection on the suction side DN_s	DN 80
Pipe connection on the discharge side DN_d	DN 80

Pump curves

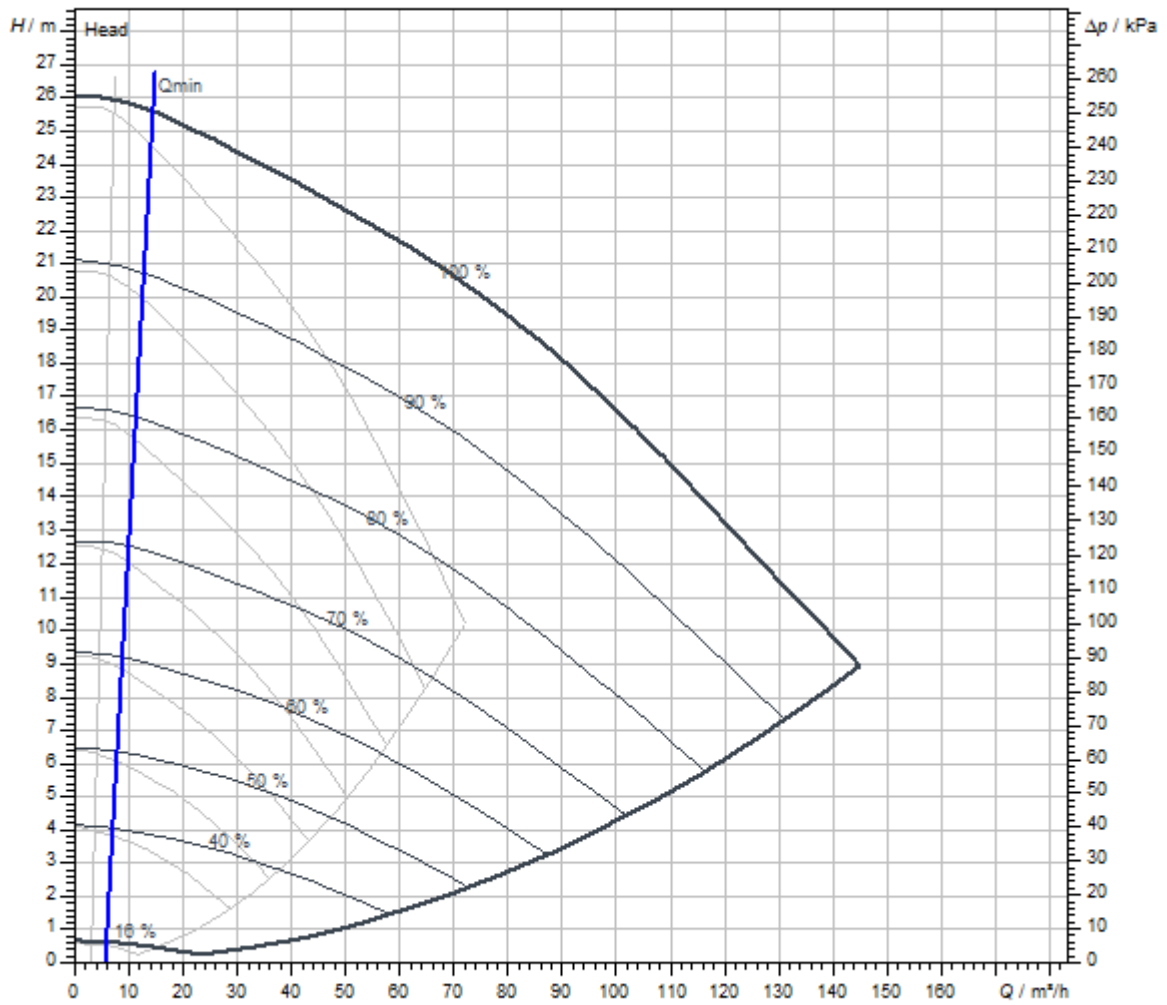

Fluid media	Water 100 %
Fluid temperature <i>T</i>	20.00 °C
speed at duty point <i>n hydr. @ OP</i>	3,140 1/min

Dimensions and dimensions drawings

Stratos GIGA2.0-D 80/1-24/3,0-R1

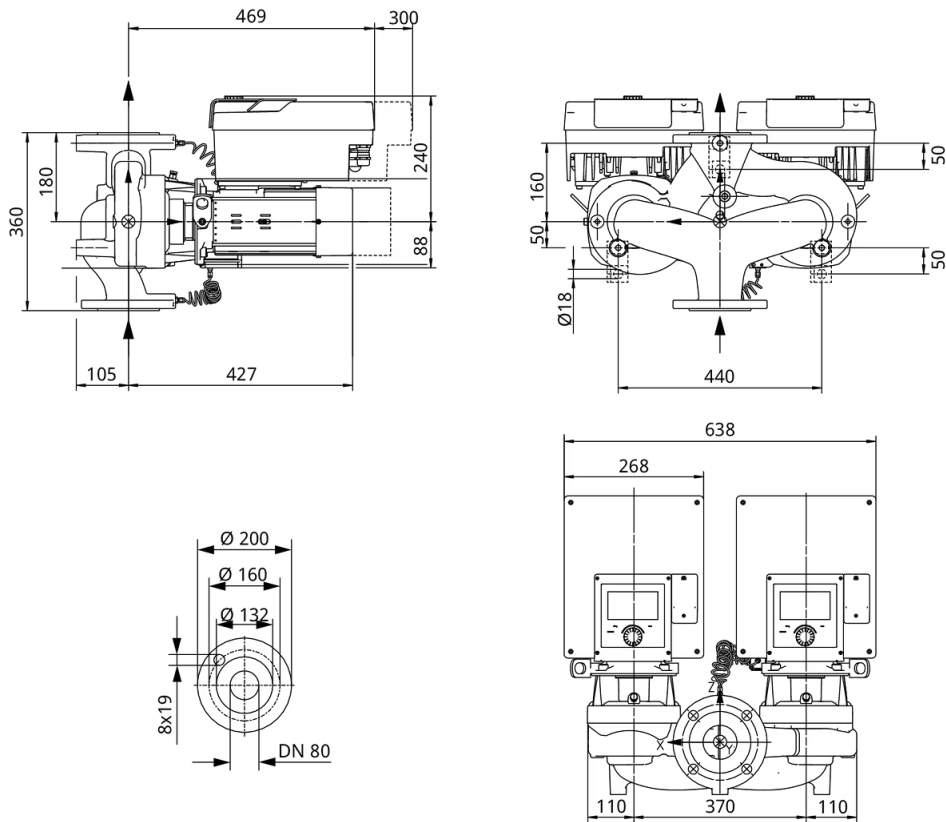

Wiring diagram

Wilo-Stratos GIGA2.0

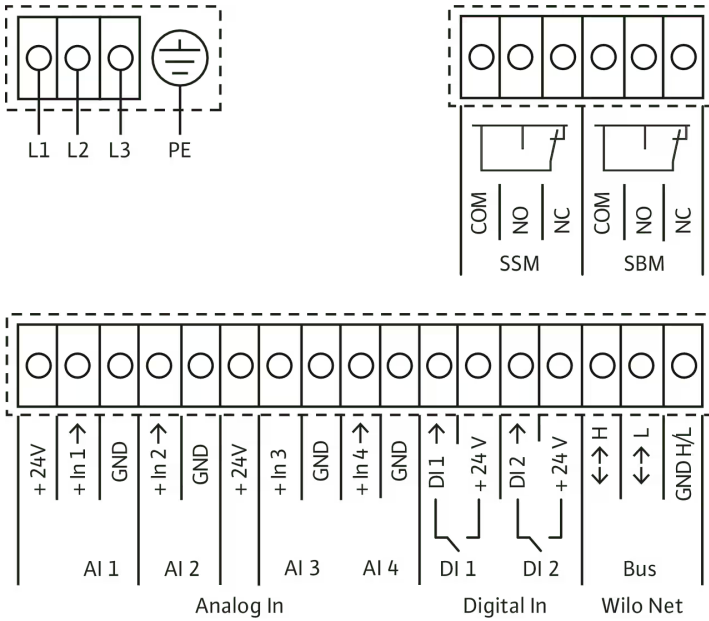

Bezeichnung

Tender text

High-efficiency in-line pump with EC motor of energy efficiency class IE5 in accordance with IEC 60034-30-2, hydraulics with minimum efficiency index $MEI \geq 0.7$ and electronic power adjustment in glanded pump construction. The pump is configured as a single-stage low-pressure centrifugal pump with flange connection and mechanical seal. The **Stratos GIGA2.0-D** has been predominantly designed for pumping heating water (acc. to VDI 2035), cold water and water-glycol mixtures without abrasive substances in heating, air-conditioning and cooling systems.

Design ...-R1:

- > Single-stage low-pressure centrifugal pump with one-piece shaft in monobloc design
- > Spiral housing in in-line design (suction and discharge ports with the same flanges in a line)
- > PN 16 flange – in accordance with EN 1092-2
- > Pressure measuring connections (R 1/8) for retrofitting of a differential pressure sensor (version ...-R1 without differential pressure sensor)
- > Pump housing and motor flange with cataphoretic coating as standard
- > Mechanical seal for pumping water up to $T_{max.} = +140\text{ °C}$. A glycol admixture of 20 % to +40 % by volume is permitted up to $T \leq +40\text{ °C}$. An alternative mechanical seal must be provided in water-glycol mixtures with glycol proportions > 40 % up to max. 50 % by volume and a fluid temperature of > +40 °C up to max. +120 °C or fluids other than water. When using water-glycol mixtures, the use of an S1 variant with a corresponding mechanical seal is generally recommended.
- > Connection voltages:
 - > 3~440 V $\pm 10\%$ 50/60 Hz; 3~400 V $\pm 10\%$ 50/60 Hz; 3~380 V -5 % +10 % 50/60 Hz
 - > Version M-: 1~220 V ... 240 V ($\pm 10\%$), 50/60 Hz
- > Compliance with electromagnetic compatibility without additional measures
 - > Interference emission for residential environment according to EN 61800-3:2018
 - > Interference immunity for industrial environments according to EN 61800-3:2018

Control modes:

- > Constant speed (**n-const.**)
- > Constant temperature (**T-const.**)
- > Constant differential temperature (**dT-const.**)
- > User-defined **PID** control
- > Only possible with differential pressure sensor:
 - > Permanent, automatic performance adjustment to system requirements without setpoint specification **Wilo Dynamic Adapt plus** (factory setting).
 - > Needs-based volume flow optimisation of the feeder pump through connectivity and communication between multiple secondary pumps (**Multi-Flow Adaptation**).
- > Constant volume flow (**Q-const.**)
- > Variable differential pressure (**dp-v**) with the option to set the nominal duty point Q and H
- > Constant differential pressure (**dp-c**)
- > Differential pressure control (dp-c) to a remote point in the pipe network (**index circuit evaluator**)

Functions:

- > Selection of the field of application in the **setting assistant**
- > **Operating modes of twin-head pump: Main/standby operation**
- > **Switchover** between **heating and cooling mode** (automatic, external or manual)
- > Ability to save and restore configured pump settings (**3 restoration points**)
- > **Fault and warning messages** shown in plain text with advice on resolving the issue
- > Integrated **full motor protection**
- > Only possible with differential pressure sensor:
 - > **Heat quantity measurement**
 - > **Cooling quantity measurement**
 - > Adjustable volume flow limiter using the Q-Limit function (**Q_{min.}** and **Q_{max.}**)
 - > Pump automatically deactivates when no flow is detected (**No-Flow Stop**)
 - > Efficiency-optimised **parallel operation** for dp-c and dp-v

Display in the "Home screen" of the graphic display:

- > Control mode currently set
- > Current setpoint
- > Current volume flow (only if a differential pressure sensor is connected)
- > Current fluid temperature (only if temperature sensor is connected)
- > Current power consumption
- > Cumulative electric consumption

Version:

- > **4** configurable **analogue inputs**: 0 – 10 V, 2–10 V, 0 – 20 mA, 4 – 20 mA and commercially available PT1000 (only on two analogue inputs); +24 V DC power supply
- > **2** configurable **digital inputs** (Ext. OFF, Ext. Min, Ext. Max, heating/cooling, manual override (uncoupled from building automation), operation lock (key lock and remote operation configuration protection))
- > **2** configurable **signal relays** for **run signals and fault messages**
- > **Slot for Wilo-CIF modules** with interfaces for building automation (BA) (optional accessories: CIF modules Modbus RTU, BACnet MS/TP, LON, PLR, CAN)
- > **Wilo Net** as a Wilo system bus for communication between Wilo products, e.g. Multi-Flow Adaptation; twin-head pump operation
- > **Automatic emergency operation** with definable pump speed for exceptional circumstances, e.g. bus communication or sensor value malfunction
- > **Rotatable, graphic colour display** (4.3 inches) with one button manual operation level
- > **Bluetooth interface** via Wilo-Smart Connect module BT
- > Use the Wilo-Assistant app to read and set operating data and –among other things– set up a commissioning protocol through the Bluetooth interface
- > Integrated **dual pump management** (twin-head pumps are prewired) when using 2 single pumps as twin-head pump unit (connection via Wilo Net)
- > **Cable break detection** when using an analogue signal (in connection with 2 – 10 V or 4 – 20 mA)
- > **Time stamp** for error/warnings and historical operating data
- > Continuous **operating data memory**
- > Standard **condensate drainage holes** in the motor housing (closed upon delivery)
- > **Air vent valve** on the lantern

Scope of delivery:

- > Pump
- > Wilo-Smart Connect Module BT
- > Threaded cable glands with sealing inserts
- > Installation and operating instructions and declaration of conformity

Accessories must be ordered separately:

3 mounting brackets with fixation material for installation on a base

- > Blind flanges for twin-head pump housing
- > Installation aid for mechanical seal (incl. mounting bolts)
- > For connection to building automation:
 - > CIF module PLR
 - > CIF module LON
 - > CIF module BACnet MS/TP
 - > Modbus RTU CIF module
 - > CIF module CANopen
 - > CIF module Ethernet Multi-protocol (Modbus TCP, BACnet/IP)
 - > Connection M12 RJ45 CIF Ethernet
- > Differential pressure sensor DPS 2 ... 10 V
- > Differential pressure sensor DPS 4 ... 20 mA
- > Temperature sensor PT1000 AA
- > Sensor sleeves for the installation of temperature sensors in the pipe

Operating Data

Min. fluid temperature T_{\min}	-20 °C
Max. fluid temperature T_{\max}	140 °C
Min. ambient temperature T_{\min}	0 °C
Max. ambient temperature T_{\max}	50 °C
Maximum operating pressure P_N	16 bar
Minimum efficiency index (MEI)	≥ 0.7

Drive

Mains connection	3~400 V, 50/60 Hz
Motor efficiency class	IE5
Power consumption $P_{1\max}$	3300 W
Rated power P_2	3 kW
Max current I_{\max}	5.1 A
Max. speed n_{\max}	3150 1/min
Emitted interference	EN 61800-3
Interference resistance	EN 61800-3
Insulation class	F
Protection class motor	IP55
Motor protection	PTC integrated

Materials

Pump housing	Grey cast iron
Impeller	PPS-GF40
Shaft	Stainless steel
Shaft seal	AQ1EGG
Lantern	5.1301/EN-GJL-250 KTL-coated

Installation dimensions

Pipe connection on the suction side DN_s	DN 80
Pipe connection on the discharge side DN_d	DN 80
Port-to-port length L_0	360 mm

Ordering information

Brand	Wilo
Product description	Stratos GIGA2.0-D 80/1-24/3,0-R1
Net weight, approx. m	101 kg
Article number	2205763 