



## Data sheet

### Hydraulic data

Minimum efficiency index (MEI)	≥0.7
Maximum operating pressure $P_N$	16 bar
Min. fluid temperature $T_{min}$	-20 °C
Max. fluid temperature $T_{max}$	140 °C
Min. ambient temperature $T_{min}$	0 °C
Max. ambient temperature $T_{max}$	50 °C

### Drive

Mains connection	3~400 V, 50/60 Hz
Number of poles	4
Motor efficiency class	IE5
Power consumption $P_{1\ max}$	4300 W
Rated power $P_2$	4 kW
Max current $I_{max}$	6.9 A
Emitted interference	EN 61800-3
Interference resistance	EN 61800-3
Insulation class	F
Protection class motor	IP55
Motor protection	PTC integrated

### Materials

Pump housing	Grey cast iron
Impeller	PPS-GF40
Shaft	Stainless steel
Shaft seal	AQ1EGG
Lantern	5.1301/EN-GJL-250 KTL-coated

### Approved liquids (other liquids upon request)

Heating water (as per VDI 2035)	yes
Heat carrier oil	Special version at additional charge
Cooling and cold water circulation systems	yes
Water-glycol mixtures (at 20 – 40 vol. % glycol and fluid temperature ≤ 40 °C)	yes

### Installation dimensions

Port-to-port length $L_0$	360 mm
Pipe connection on the suction side $DN_s$	DN 80
Pipe connection on the discharge side $DN_d$	DN 80

Pump curves

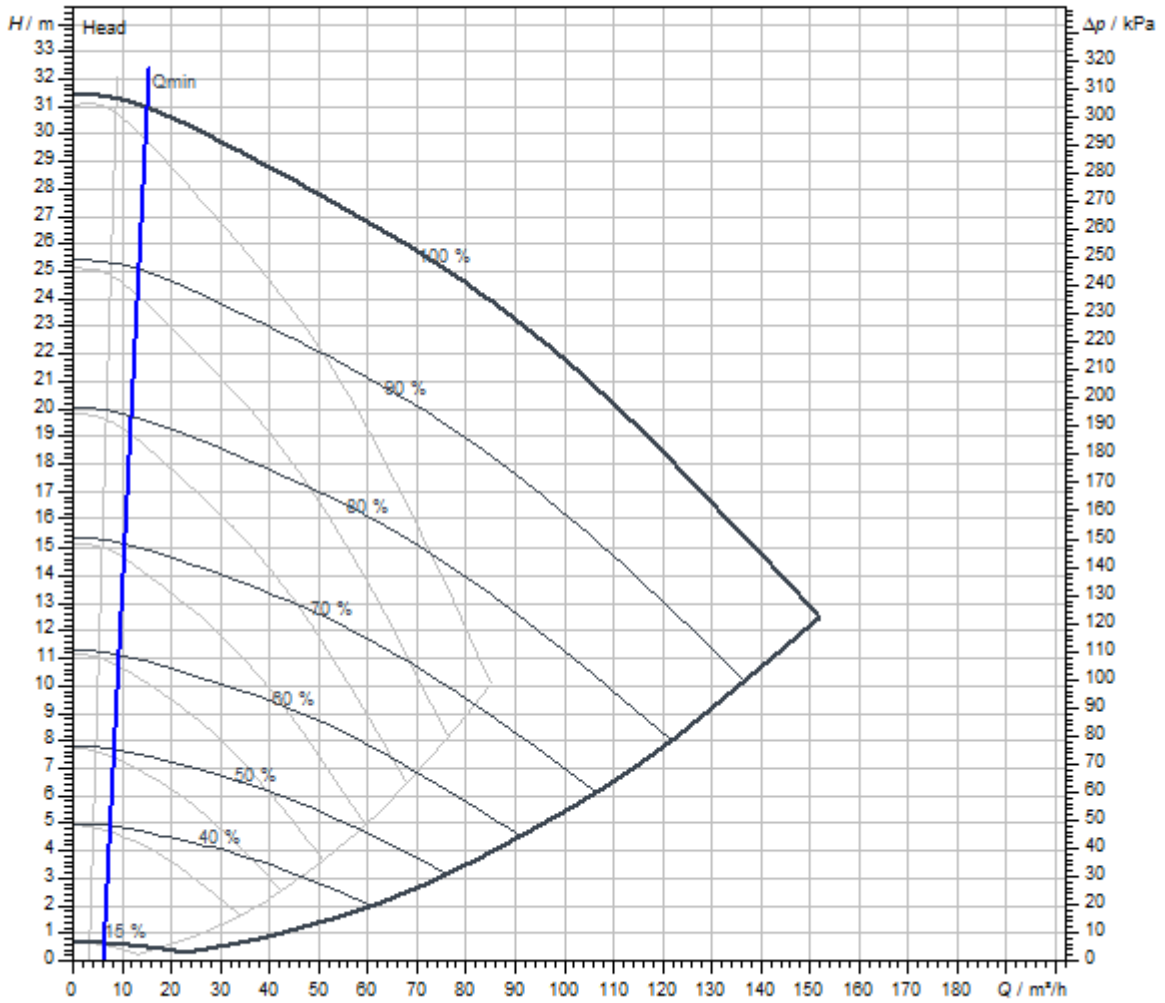

Fluid media	Water 100 %
Fluid temperature <i>T</i>	20.00 °C
speed at duty point <i>n hydr. @ OP</i>	3,461 1/min

Dimensions and dimensions drawings

Stratos GIGA2.0-D 80/1-30/4,0-R1

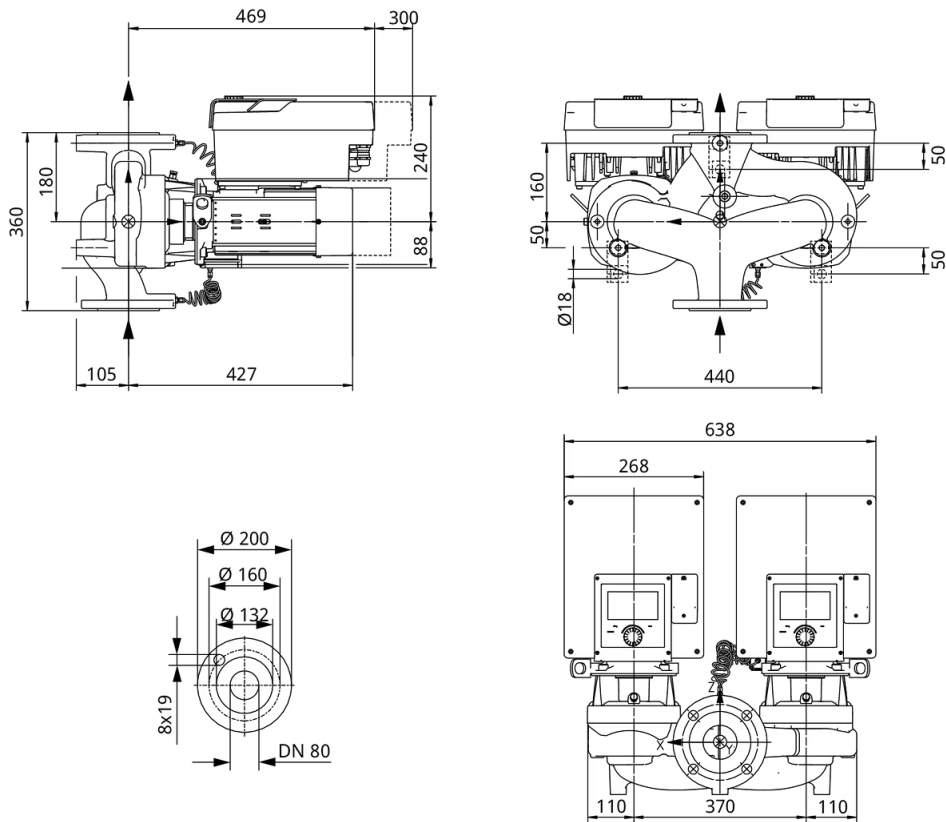

Wiring diagram

Wilo-Stratos GIGA2.0

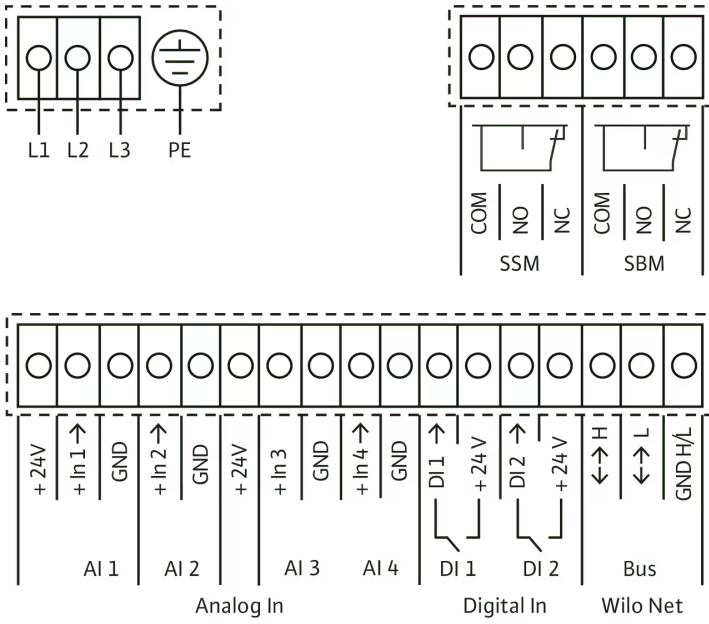

Bezeichnung

## Tender text

High-efficiency in-line pump with EC motor of energy efficiency class IE5 in accordance with IEC 60034-30-2, hydraulics with minimum efficiency index  $MEI \geq 0.7$  and electronic power adjustment in glanded pump construction. The pump is configured as a single-stage low-pressure centrifugal pump with flange connection and mechanical seal. The **Stratos GIGA2.0-D** has been predominantly designed for pumping heating water (acc. to VDI 2035), cold water and water-glycol mixtures without abrasive substances in heating, air-conditioning and cooling systems.

### Design ...-R1:

- > Single-stage low-pressure centrifugal pump with one-piece shaft in monobloc design
- > Spiral housing in in-line design (suction and discharge ports with the same flanges in a line)
- > PN 16 flange - in accordance with EN 1092-2
- > Pressure measuring connections (R 1/8) for retrofitting of a differential pressure sensor (version ...-R1 without differential pressure sensor)
- > Pump housing and motor flange with cataphoretic coating as standard
- > Mechanical seal for pumping water up to  $T_{max.} = +140\text{ °C}$ . A glycol admixture of 20 % to +40 % by volume is permitted up to  $T \leq +40\text{ °C}$ . An alternative mechanical seal must be provided in water-glycol mixtures with glycol proportions > 40 % up to max. 50 % by volume and a fluid temperature of > +40 °C up to max. +120 °C or fluids other than water. When using water-glycol mixtures, the use of an S1 variant with a corresponding mechanical seal is generally recommended.
- > Connection voltages:
  - > 3~440 V  $\pm 10\%$  50/60 Hz; 3~400 V  $\pm 10\%$  50/60 Hz; 3~380 V -5 % +10 % 50/60 Hz
  - > Version M-: 1~220 V ... 240 V ( $\pm 10\%$ ), 50/60 Hz
- > Compliance with electromagnetic compatibility without additional measures
  - > Interference emission for residential environment according to EN 61800-3:2018
  - > Interference immunity for industrial environments according to EN 61800-3:2018

### Control modes:

- > Constant speed (**n-const.**)
- > Constant temperature (**T-const.**)
- > Constant differential temperature (**dT-const.**)
- > User-defined **PID** control
- > Only possible with differential pressure sensor:
  - > Permanent, automatic performance adjustment to system requirements without setpoint specification **Wilo Dynamic Adapt plus** (factory setting).
  - > Needs-based volume flow optimisation of the feeder pump through connectivity and communication between multiple secondary pumps (**Multi-Flow Adaptation**).
- > Constant volume flow (**Q-const.**)
- > Variable differential pressure (**dp-v**) with the option to set the nominal duty point Q and H
- > Constant differential pressure (**dp-c**)
- > Differential pressure control (dp-c) to a remote point in the pipe network (**index circuit evaluator**)

### Functions:

- > Selection of the field of application in the **setting assistant**
- > **Operating modes of twin-head pump: Main/standby operation**
- > **Switchover** between **heating and cooling mode** (automatic, external or manual)
- > Ability to save and restore configured pump settings (**3 restoration points**)
- > **Fault and warning messages** shown in plain text with advice on resolving the issue
- > Integrated **full motor protection**
- > Only possible with differential pressure sensor:
  - > **Heat quantity measurement**
  - > **Cooling quantity measurement**
  - > Adjustable volume flow limiter using the Q-Limit function (**Q<sub>min.</sub>** and **Q<sub>max.</sub>**)
  - > Pump automatically deactivates when no flow is detected (**No-Flow Stop**)
  - > Efficiency-optimised **parallel operation** for dp-c and dp-v

### Display in the "Home screen" of the graphic display:

- > Control mode currently set
- > Current setpoint
- > Current volume flow (only if a differential pressure sensor is connected)
- > Current fluid temperature (only if temperature sensor is connected)
- > Current power consumption
- > Cumulative electric consumption

**Version:**

- > **4** configurable **analogue inputs**: 0 – 10 V, 2–10 V, 0 – 20 mA, 4 – 20 mA and commercially available PT1000 (only on two analogue inputs); +24 V DC power supply
- > **2** configurable **digital inputs** (Ext. OFF, Ext. Min, Ext. Max, heating/cooling, manual override (uncoupled from building automation), operation lock (key lock and remote operation configuration protection))
- > **2** configurable **signal relays** for **run signals and fault messages**
- > **Slot for Wilo-CIF modules** with interfaces for building automation (BA) (optional accessories: CIF modules Modbus RTU, BACnet MS/TP, LON, PLR, CAN)
- > **Wilo Net** as a Wilo system bus for communication between Wilo products, e.g. Multi-Flow Adaptation; twin-head pump operation
- > **Automatic emergency operation** with definable pump speed for exceptional circumstances, e.g. bus communication or sensor value malfunction
- > **Rotatable, graphic colour display** (4.3 inches) with one button manual operation level
- > **Bluetooth interface** via Wilo-Smart Connect module BT
- > Use the Wilo-Assistant app to read and set operating data and –among other things– set up a commissioning protocol through the Bluetooth interface
- > Integrated **dual pump management** (twin-head pumps are prewired) when using 2 single pumps as twin-head pump unit (connection via Wilo Net)
- > **Cable break detection** when using an analogue signal (in connection with 2 – 10 V or 4 – 20 mA)
- > **Time stamp** for error/warnings and historical operating data
- > Continuous **operating data memory**
- > Standard **condensate drainage holes** in the motor housing (closed upon delivery)
- > **Air vent valve** on the lantern

**Scope of delivery:**

- > Pump
- > Wilo-Smart Connect Module BT
- > Threaded cable glands with sealing inserts
- > Installation and operating instructions and declaration of conformity

**Accessories** must be ordered separately:

3 mounting brackets with fixation material for installation on a base

- > Blind flanges for twin-head pump housing
- > Installation aid for mechanical seal (incl. mounting bolts)
- > For connection to building automation:
  - > CIF module PLR
  - > CIF module LON
  - > CIF module BACnet MS/TP
  - > Modbus RTU CIF module
  - > CIF module CANopen
  - > CIF module Ethernet Multi-protocol (Modbus TCP, BACnet/IP)
  - > Connection M12 RJ45 CIF Ethernet
- > Differential pressure sensor DPS 2 ... 10 V
- > Differential pressure sensor DPS 4 ... 20 mA
- > Temperature sensor PT1000 AA
- > Sensor sleeves for the installation of temperature sensors in the pipe

**Operating Data**

Min. fluid temperature $T_{\min}$	-20 °C
Max. fluid temperature $T_{\max}$	140 °C
Min. ambient temperature $T_{\min}$	0 °C
Max. ambient temperature $T_{\max}$	50 °C
Maximum operating pressure $P_N$	16 bar
Minimum efficiency index (MEI)	≥0.7

### Drive

Mains connection	3~400 V, 50/60 Hz
Motor efficiency class	IE5
Power consumption $P_{1\max}$	4300 W
Rated power $P_2$	4 kW
Max current $I_{\max}$	6.9 A
Max. speed $n_{\max}$	3460 1/min
Emitted interference	EN 61800-3
Interference resistance	EN 61800-3
Insulation class	F
Protection class motor	IP55
Motor protection	PTC integrated

### Materials

Pump housing	Grey cast iron
Impeller	PPS-GF40
Shaft	Stainless steel
Shaft seal	AQ1EGG
Lantern	5.1301/EN-GJL-250 KTL-coated

### Installation dimensions

Pipe connection on the suction side $DN_s$	DN 80
Pipe connection on the discharge side $DN_d$	DN 80
Port-to-port length $L_0$	360 mm

### Ordering information

Brand	Wilo
Product description	Stratos GIGA2.0-D 80/1-30/4,0-R1
Net weight, approx. $m$	104 kg
Article number	<b>2205762</b> 

## Installation type

### Continuous, infinitely variable control, differential pressure-sensitive CCe-HVAC system

#### CCe-HVAC system

CCe-HVAC system 1 x 2.2	2536676
CCe-HVAC system 2 x 2.2	2536677
CCe-HVAC system 3 x 2.2	2536678
CCe-HVAC system 4 x 2.2	2536679
CCe-HVAC system 5 x 2.2	2536680
CCe-HVAC system 6 x 2.2	2536681

#### Antenna GSM/GPRS

D-network dual-band antenna with 3 m cable	2533862
D-network tri-band antenna 10 m cable	2533863
D-network tri-band antenna 15 m cable	2533864

#### Outdoor temperature sensor Pt 100

Outdoor temperature sensor Pt 100	2533772
-----------------------------------	---------

#### DDG impulse selector

DDG impulse selector	2533770
----------------------	---------

#### BMS base module

BMS base module	2533800
-----------------	---------

#### CC communication module BACnet

CC-communication module BACnet IP (slave)	2537051
CC-communication module BACnet MS/TP (slave)	2537050

#### Communication module LON

Communication module LON	2533868
--------------------------	---------

#### Communication module ModBus

Communication module Modbus RTU	2533869
---------------------------------	---------

#### Communication module Profibus

Communication module Profibus DP	2533866
----------------------------------	---------

#### Communication module CC

CC communication module	2533850
-------------------------	---------



### Communication module GSM

GSM module	2533861
------------	---------

### Pump signalling module

Signalling module pump 1-2	2533812
----------------------------	---------

Signalling module pump 3-6	2533836
----------------------------	---------

### Signal converter retrofit kit

Signal converter 0-10 V / 0-20 mA	2534992
-----------------------------------	---------

### Connection cable control modules/signalling modules

Control modules connecting cable	2533790
----------------------------------	---------

Signalling modules connecting cable	2533890
-------------------------------------	---------

### DDG transducer

DDG transducer	501771990
----------------	-----------

### DDG power supply unit

DDG power supply unit	501865293
-----------------------	-----------

### Extension kit differential pressure sensor for Y-piece application

Extension for DDG-kit	2166098
-----------------------	---------

## Continuous, infinitely variable control, temperature-dependent CCe-HVAC system

### CCe-HVAC system

CCe-HVAC system 1 x 2.2	2536676
-------------------------	---------

CCe-HVAC system 2 x 2.2	2536677
-------------------------	---------

CCe-HVAC system 3 x 2.2	2536678
-------------------------	---------

CCe-HVAC system 4 x 2.2	2536679
-------------------------	---------

CCe-HVAC system 5 x 2.2	2536680
-------------------------	---------

CCe-HVAC system 6 x 2.2	2536681
-------------------------	---------

### Antenna GSM/GPRS

D-network dual-band antenna with 3 m cable	2533862
--	---------

D-network tri-band antenna 10 m cable	2533863
---------------------------------------	---------

D-network tri-band antenna 15 m cable	2533864
---------------------------------------	---------

### Outdoor temperature sensor Pt 100

Outdoor temperature sensor Pt 100	2533772
-----------------------------------	---------

### BMS base module

BMS base module	2533800
<b>CC communication module BACnet</b>	
CC-communication module BACnet IP (slave)	2537051
CC-communication module BACnet MS/TP (slave)	2537050
<b>Communication module LON</b>	
Communication module LON	2533868
<b>Communication module ModBus</b>	
Communication module Modbus RTU	2533869
<b>Communication module Profibus</b>	
Communication module Profibus DP	2533866
<b>Communication module CC</b>	
CC communication module	2533850
<b>Communication module GSM</b>	
GSM module	2533861
<b>Pump signalling module</b>	
Signalling module pump 1-2	2533812
Signalling module pump 3-6	2533836
<b>Signal converter retrofit kit</b>	
Signal converter 0-10 V / 0-20 mA	2534992
<b>Temperature module</b>	
Temperature module for systems with 1-3 pumps	2534991
Temperature module for systems with 4-6 pumps	2533771
<b>Connection cable control modules/signalling modules</b>	
Control modules connecting cable	2533790
Signalling modules connecting cable	2533890
<b>Continuous, infinitely variable control, differential pressure-sensitive SCe-HVAC system</b>	
<b>SCe-HVAC system</b>	
SCe-HVAC system 1x10A-WM	2545254
SCe-HVAC system 2x10A-WM	2545255
SCe-HVAC system 3x10A-WM	2545256

SCe-HVAC system 4x10A-WM	2545257
<b>Antenna GSM/GPRS</b>	
D-network dual-band antenna with 3 m cable	2533862
D-network tri-band antenna 10 m cable	2533863
D-network tri-band antenna 15 m cable	2533864
<b>Outdoor temperature sensor Pt 100</b>	
Outdoor temperature sensor Pt 100	2533772
<b>DDG impulse selector</b>	
DDG impulse selector	2533770
<b>Communication module LON (SC)</b>	
Communication module LON (SC)	2538243
<b>SC communication module BACnet</b>	
SC-communication module BACnet MS/TP (slave)	2538242
<b>Communication module GSM (SC)</b>	
Communication module GSM (SC)	2542216
<b>Pump signalling module</b>	
Signalling module pump 1-2	2533812
Signalling module pump 3-6	2533836
<b>SC-HVAC signal board</b>	
SC-HVAC signal board	2119646
<b>DDG transducer</b>	
DDG transducer	501771990
<b>DDG power supply unit</b>	
DDG power supply unit	501865293
<b>Extension kit differential pressure sensor for Y-piece application</b>	
Extension for DDG-kit	2166098