

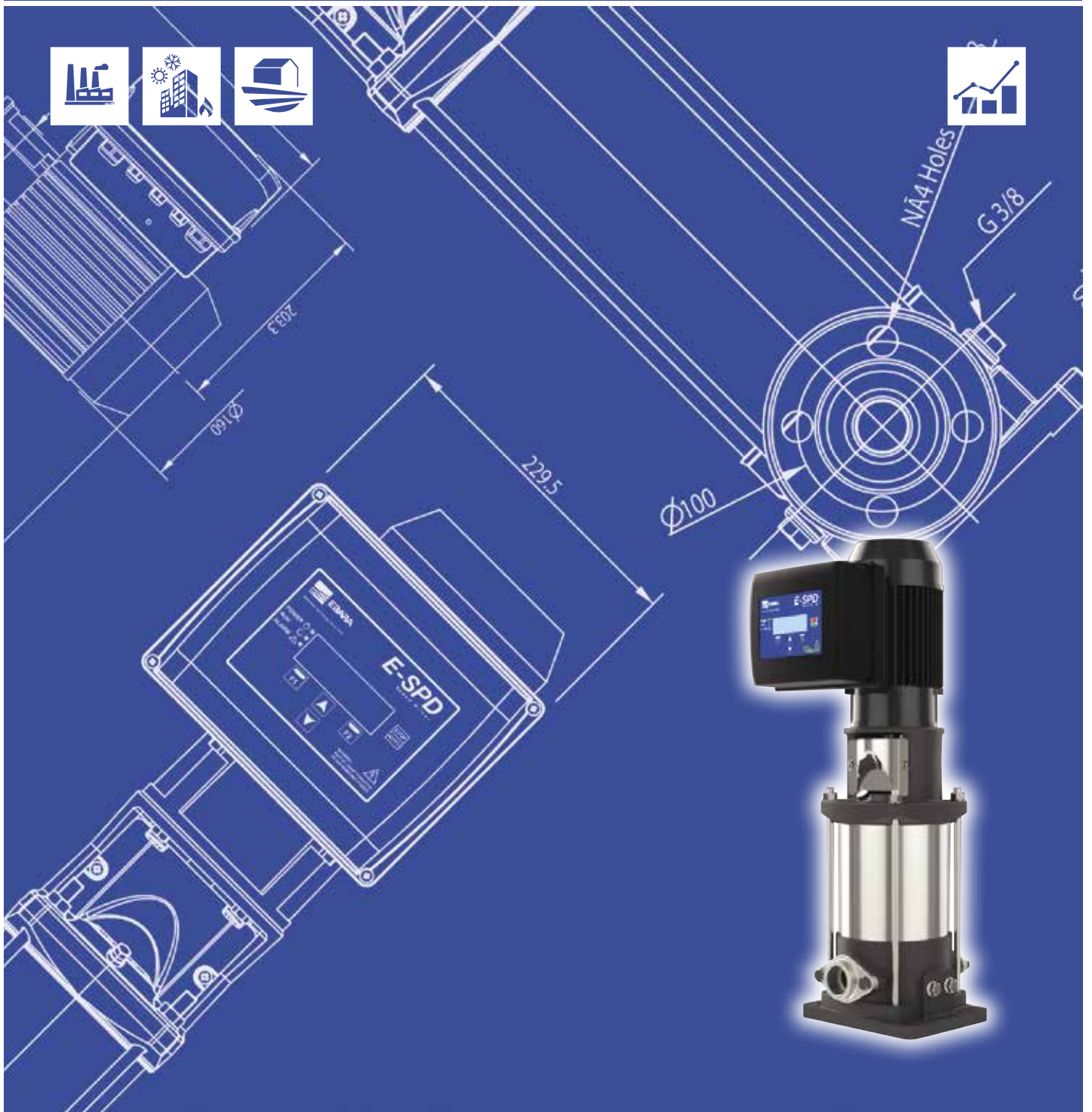

Japanese Technology since 1912

## EVMS-K - Vertical Multistage Pumps

Data Book 50Hz



### INDEX

	Page
<b>INDEX</b>	<b>2</b>
<b>DEFINITION AND USE OF EVMS-K</b>	<b>101</b>
<b>TYPICAL APPLICATIONS</b>	<b>101</b>
<b>PRINCIPLE OF OPERATION</b>	<b>101</b>
<b>OPERATING CONDITIONS</b>	<b>101</b>
TESTS AND TRIALS	102
MECHANICAL AND HYDRAULIC TESTS	102
ELECTRICAL TESTS	102
Principle of Operation of UNITS	102
<b>PRESSURISATION UNIT WATER CIRCUIT DIAGRAM</b>	<b>103</b>
<b>TYPE KEY</b>	<b>104</b>
<b>NAME PLATE</b>	<b>202</b>
<b>PRODUCT SPECIFICATIONS</b>	<b>201</b>
PUMP WITH INVERTER	201
<b>TECHNICAL PUMP DATA</b>	<b>202</b>
EVMS(.) 1-3-5-10-15-20	202
<b>TECHNICAL MOTOR DATA</b>	<b>203</b>
ETM MOTOR	203
<b>MECHANICAL SEAL DATA</b>	<b>204</b>
<b>PERFORMANCE RANGE</b>	<b>301</b>
RESEAU PUMP WITH INVERTER EVMS(.)-K1-3-5	301
RESEAU PUMP WITH INVERTER EVMS(.)-K10-15-20	302
<b>CURVE SPECIFICATION</b>	<b>401</b>
SELECTION CHART EVMS(.)-K1-3-5	402
SELECTION CHART EVMS(.)-K10-15-20	403
<b>PERFORMANCE CURVE EVMS(.)K1-3-5</b>	<b>701</b>
EVMS(.)-K1 14/0.75	701
EVMS(.)-K1 16/0.75	702
EVMS(.)-K1 18/1.1	703
EVMS(.)-K1 20/1.1	704
EVMS(.)-K1 22/1.1	705
EVMS(.)-K1 24/1.1	706
EVMS(.)-K1 26/1.1	707
EVMS(.)-K1 27/1.5	708
EVMS(.)-K1 29/1.5	709
EVMS(.)-K1 32/1.5	710

EVMS(.)-K1 34/1.5	711
EVMS(.)-K1 37/2.2	712
EVMS(.)-K1 39/2.2	713
EVMS(.)-K3 7/0.75	714
EVMS(.)-K3 8/0.75	715
EVMS(.)-K3 9/1.1	716
EVMS(.)-K3 10/1.1	717
EVMS(.)-K3 11/1.1	718
EVMS(.)-K3 12/1.1	719
EVMS(.)-K3 13/1.5	720
EVMS(.)-K3 14/1.5	721
EVMS(.)-K3 15/1.5	722
EVMS(.)-K3 16/1.5	723
EVMS(.)-K3 17/2.2	724
EVMS(.)-K3 19/2.2	725
EVMS(.)-K3 21/2.2	726
EVMS(.)-K3 23/2.2	727
EVMS(.)-K3 24/2.2	728
EVMS(.)-K3 25/3.0	729
EVMS(.)-K3 27/3.0	730
EVMS(.)-K3 29/3.0	731
EVMS(.)-K3 31/3.0	732
EVMS(.)-K3 33/3.0	733
EVMS(.)-K5 4/0.75	734
EVMS(.)-K5 5/1.1	735
EVMS(.)-K5 6/1.5	736
EVMS(.)-K5 7/1.5	737
EVMS(.)-K5 8/2.2	738
EVMS(.)-K5 9/2.2	739
EVMS(.)-K5 10/2.2	740
EVMS(.)-K5 11/2.2	741
EVMS(.)-K5 12/3.0	742
EVMS(.)-K5 13/3.0	743
EVMS(.)-K5 14/3.0	744
EVMS(.)-K5 15/3.0	745
EVMS(.)-K5 17/4.0	746
EVMS(.)-K5 19/4.0	747
EVMS(.)-K5 20/4.0	748
EVMS(.)-K10 2/0.75	749
EVMS(.)-K10 3/1.5	750

EVMS(.)-K10 4/2.2	751
EVMS(.)-K10 5/2.2	752
EVMS(.)-K10 6/2.2	753
EVMS(.)-K10 7/3.0	754
EVMS(.)-K10 8/3.0	755
EVMS(.)-K10 9/4.0	756
EVMS(.)-K10 10/4.0	757
EVMS(.)-K10 11/4.0	758
EVMS(.)-K15 1/1.1	759
EVMS(.)-K15 2/2.2	760
EVMS(.)-K15 3/3.0	761
EVMS(.)-K15 4/4.0	762
EVMS(.)-K20 1/1.5	763
EVMS(.)-K20 2/3.0	764
EVMS(.)-K20 3/4.0	765
<b>PUMP WITH INVERTER CONSTRUCTION</b>	<b>766</b>
<b>OVERALL DIMENSIONS PUMP WITH INVERTER</b>	<b>767</b>
EVMS(L)-K1	767
EVMSG-K1	768
EVMS(L)-K3	769
EVMSG-K3	770
EVMS(L)-K5	771
EVMSG-K5	772
EVMS(L)-K10	773
EVMSG-K10	774
EVMS(L)-K15	775
EVMSG-K15	776
EVMS(L)-K20	777
EVMSG-K20	778
<b>PACKING</b>	<b>779</b>
EVMS(.)-K 1-3-5	780
EVMS(.)-K 10-15-20	781
<b>CONTROL PANEL VARIABLE SPEED</b>	<b>801</b>
E-SPD SPECIFICATION	801

### DEFINITION AND USE OF EVMS-K

The EVMS-K is non-self-priming, vertical multistage in line, centrifugal pumps with VFD.

### TYPICAL APPLICATIONS

INDUSTRY	BUILDING SERVICE	WATER SUPPLY
		

### PRINCIPLE OF OPERATION

**EVMS-K** units are designed to operate with a pump controlled by an **INVERTER** on board the motor. The unit thus maintains constant pressure in the water circuit. With a single **INVERTER** controlling a single pump.

### OPERATING CONDITIONS

Ebara EVMS-K can be used, in their standard versions, for civil, industrial and agricultural applications, as follows:

- building service
- water lifting and handling
- irrigation
- washing systems

The conveyed fluid must be: clean, potable, ground or mixed water, free of solid or fibrous suspensions and aggressive chemical substances.

The units must be installed under cover, protected from the weather and freezing.

- Conveyed water temperature 0 - 80°C (depending on pumps).
- Ambient operating temperature 0 - 40°C, no higher than 1000 m above sea level.
- Max relative humidity 50% at +40°C.

NB: The system available NPSH must be greater than the NPSH demanded from the pump. For applications with different technical specifications, uses and climatic conditions (type of vector fluid, marine and aggressive industrial conditions), please contact our sales network.

### TESTS AND TRIALS

Before shipping, all EBARA pressurisation units (or components) are subject to hydraulic, mechanical and electrical testing.

### MECHANICAL AND HYDRAULIC TESTS

- Pump direction of rotation
- Mechanical testing of moving parts and running noise (on each pump)
- Tightness test with delivery port closed and nameplate rating tests

### ELECTRICAL TESTS

- Earthing system continuity
- Applied voltage (dielectric rigidity)
- Insulation resistance

### Principle of Operation of UNITS

EVMS-K units with E-SPD are designed to operate with each pumps controlled by an INVERTER installed on board its motor, on the terminal box. The system is controlled by an INVERTER in relation to the reference signal supply by a pressure transmitters (4 - 20 mA passive). As the system pressure varies, the pump varies its rotary speed to restore it to the setpoint. If the water demand exceeds the capacity, the pump goes into regulation mode to maintain the pressure setpoint. If the water demand drops off, the pressure tends to increase and the pump gradually reduces its speed to restore the correct operating pressure. Once the system pressure has been restored and the water demand is 0, the pump switches off automatically.

### PRESSURISATION UNIT WATER CIRCUIT DIAGRAM

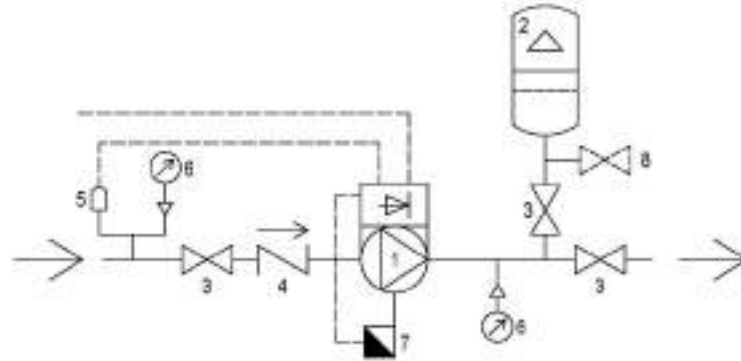

*Pressure transducer installed on pump*

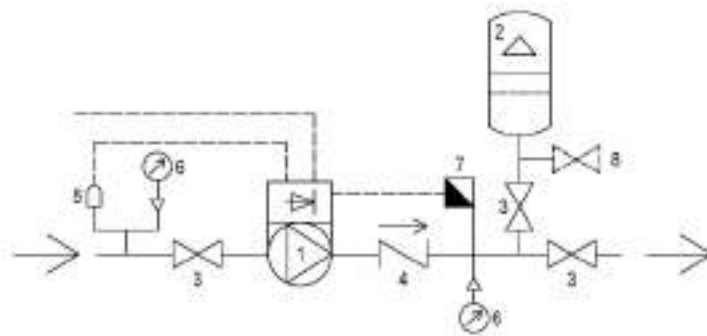

*Pressure transducer installed on pipe*

*Supply system upstream from unit at the discretion of the customer of the system designer*

- 1 – Pump with inverter “ EVMS-K ”
- 2 – Pressure vessel
- 3 – Shut-off valve
- 4 – Check valve
- 5 – Water lack control
- 6 – Pressure gauge
- 7 – Pressure Transducer
- 8 – Drain off valve

### TYPE KEY

### EVMS-K

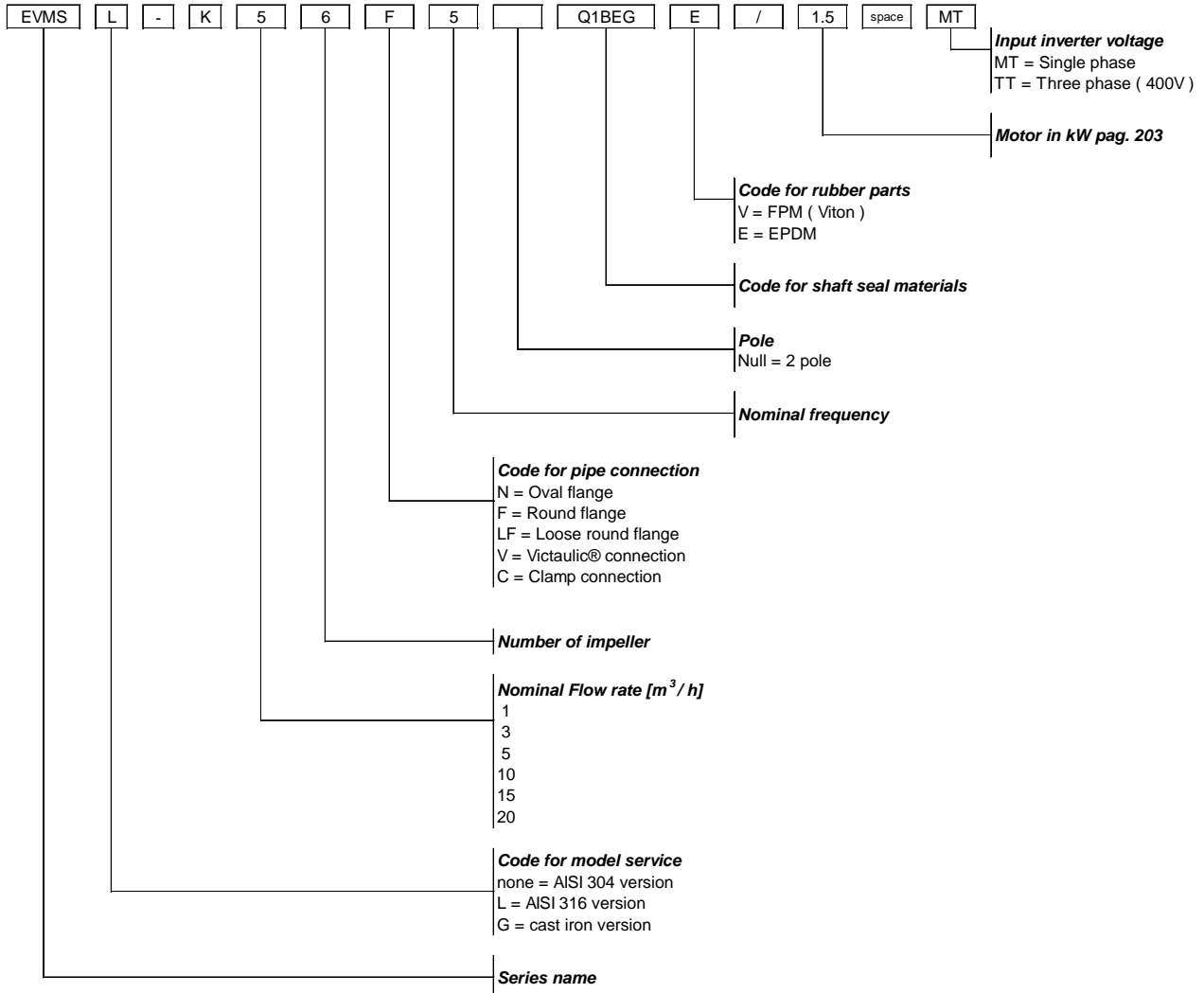



### NAME PLATE



- 1) "S/N" Serial number
- 2) "IP" Protection degree
- 3) "kg" Weight [kg]
- 4) "P/N" Pump item number
- 5) "TYPE" Pump mode

### PRODUCT SPECIFICATIONS

### PUMP WITH INVERTER

PUMP WITH INVERTER							
Version		EVMS(.)-K					
Operating range	Nominal flow rate (m <sup>3</sup> /h )	1	3	5	10	15	20
	Maximum working pressure	16 bar / 25 bar			16 bar		
	Liquid temperature range	0°C÷80°C					
	Ambient operating temperature (no higher than 1000 m above sea level)	-10°C÷40°C					
Pump	EVMS	•	•	•	•	•	•
	EVMSL	○	○	○	○	○	○
	EVMSG	○	○	○	○	○	○
Motor	ETM	From 0.75 to 4 kW					
Control	Pressure transmitter	Up to 16 bar EN 10088-1.4301 (AISI 304) / 1.4404 (AISI 316L)					
		Upper 16 bar to 25 bar EN 10088-1.4301 (AISI 304) / 1.4404 (AISI 316L)			-		
Inverter	E-SPD	Single-phase Supply inverter up to 2.2 kW					
		Three-phase Supply inverter up to 4 kW					

• : Standard ○ : Optional

### TECHNICAL PUMP DATA

#### EVMS(.) 1-3-5-10-15-20

		PUMP																		
Version		EVMSG						EVMS						EVMSL						
		1	3	5	10	15	20	1	3	5	10	15	20	1	3	5	10	15	20	
Operating range	Nominal flow rate (m <sup>3</sup> /h)																			
	Maximum working pressure	16 bar / 25 bar																		
	Liquid temperature range	-30°C÷140°C [1]																		
Key Components Material	Impeller	EN 1.4301 (AISI 304)						EN 1.4404 (AISI 316L)												
	Intermediate casing	EN 1.4301 (AISI 304)						EN 1.4404 (AISI 316L)												
	Liner ring	EN 1.4301 (AISI 304) + PPS						EN 1.4301 (AISI 304) + PPS												
	Bottom casing	Cast iron						EN 1.4301 (AISI 304)						EN 1.4404 (AISI 316L)						
	Casing cover	EN 1.4301 (AISI 304)						EN 1.4404 (AISI 316L)												
	Shaft	EN 1.4301 (AISI 304)	EVMSG / EVMS 1-3-10 . EVMSG / EVMS 5-15-20 (depend on models)																	
		EN 1.4404 (AISI 316L)	EVMSL 1-3-10 . EVMSL 5-15-20 (depend on models)																	
		EN 1.4462 (AISI 329A)	EVMSG / EVMS / EVMSL 5-15-20 (depend on models)																	
	Shaft sleeve bearing	Tungsten carbide																		
	Shaft seal	See the shaft seal options																		
	O-ring	EPDM	●	●	●	●	●	●	●	●	●	●	●	●	●	●	●	●	●	●
		FPM	●	●	●	●	●	●	●	●	●	●	●	●	●	●	●	●	●	●
	Outer casing	EN 1.4301 (AISI 304)						EN 1.4404 (AISI 316L)												
	Motor Bracket	Cast iron																		
	Tie rod	Galvanized steel 6.8 strenght class ISO 898/1																		
Coupling	Die cast aluminium																			
Base	Cast Iron						Die cast aluminium													
Pipe Connexion	Oval Flange	Up to 16 bar	○	○	○	○	○	○	○	○	○	○	○	○	○	○	○	○	○	
	Round Flange (DIN)	Up to 16 bar	○	○	○	○	○	○	○	○	○	○	○	○	○	○	○	○	○	
		From 16 bar to 25 bar	○	○	○	○	○	●	●	●	●	●	●	○	○	○	○	○	○	
	Loose round Flange (DIN)	Up to 16 bar	-	-	-	-	-	○	○	○	○	○	○	○	○	○	○	○	○	
		From 16 bar to 25 bar	-	-	-	-	-	○	○	○	○	○	○	○	○	○	○	○	○	
Victaulic®	Up to 16 bar	-	-	-	-	-	○	○	○	○	○	○	○	○	○	○	○	○		
Clamp	Up to 16 bar	-	-	-	-	-	○	○	○	○	○	○	○	○	○	○	○	○		

● : Standard ○ : Optional  
 [1] : Verify the compatibly with the pressure trasmitter used.  
 - : Not available

### TECHNICAL MOTOR DATA

#### ETM MOTOR

		ETM MOTOR	
Version		EVMS(.)	
Power source	Frequency	50 Hz	
	Phase	Three-phase	
	Rotation speed	2900 min <sup>-1</sup>	
	Power rating	0.75 ÷ 4 kW	
		1.0 ÷ 5.5 HP	
Voltage	230/400 ± 10% V		
Type	Type	Electric - TEFC	
	Efficiency level	IE3	
	N°of poles	2	
	Protection degree	IP 55	
	Insulation class	F ( temperature rise class B )	
Others	Thermal Protection	PTC sensor pre-installed for motors of 1.5 kW and above	
	Casing Material	Aluminium	
	Flange mount (IEC motor)	IM B14 ( up to 4 kW )	
	Terminal Box fixing	Unlosable screw and sealing from 0.75 ÷ 4 kW	

Motor Model	Size	Motor		Eff.	Load efficiency and power-factor (400V)				Full load current [A]		Locked rotor current [A]		Rotation speed min <sup>-1</sup>	Input [kW]
		Coupling Flange Size	Power [kW] [HP]		η %			cos-φ	230 V	400V	230 V	400V		
					50%	75%	100%							
ETM 3 71-0,75-2	71	80	0,75 1	IE3	80,2	82,5	82,1	0,76	3,0	1,7	19,7	11,4	2845	0,92
ETM 3 71-1,1-2		80	1,1 1,5	IE3	81,3	82,8	82,7	0,77	4,3	2,5	28,8	16,6	2830	1,35
ETM 3 80-1,5-2	80	90	1,5 2	IE3	83,5	84,3	84,6	0,77	5,8	3,3	44,1	25,5	2885	1,77
ETM 3 80-2,2-2		90	2,2 3	IE3	85,7	86,8	86	0,78	8,2	4,7	63,3	36,6	2875	2,59
ETM 3 90-3-2	90	100	3,0 4	IE3	85,9	87,5	87,1	0,78		6,4		51,8	2890	3,43
ETM 3 100-4-2	100	112	4,0 5,5	IE3	86	88,3	88,1	0,75		8,7		76,1	2920	4,65

### MECHANICAL SEAL DATA

#### SHAFT SEAL EVMS(.)1-3-5-10-15-20

#### 1. Shaft Seal

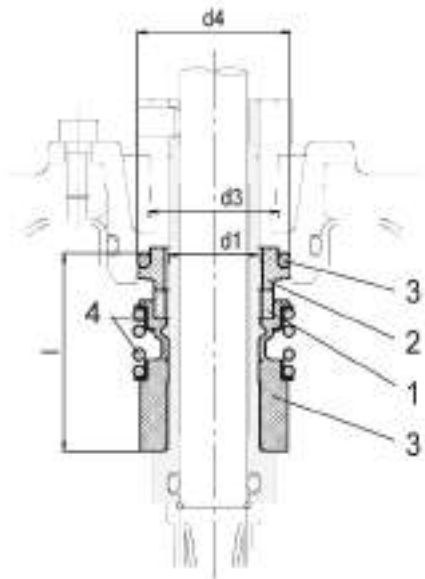

up to 16 bar  
Cartridge Unbalanced type

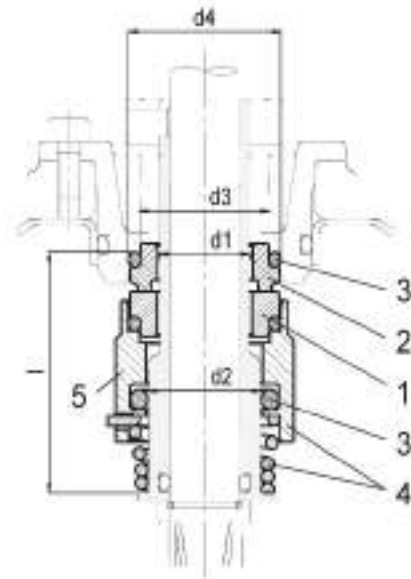

up to 25 bar  
Cartridge Balanced type

#### 2. Type of Shaft Seal and Dimensions [mm]

Type key	Availability	Max operating pressure	Max operating temperature	Shaft seal type		Shaft seal material									
				Cartridge		1		2		3		4		5	
				Type	Code	Rotating part	Code	Stationary part	Code	Elastomer	Code	Compression spring	Collar	Code	
Q1BEG	●	16 bar	-30°C to +120°C	Unbalanced	(-)	SiC	(Q1)	Carbon	(B)	EPDM	(E)	AISI 316	(G)		
BQ1VG	○	16 bar	-30°C to +80°C	Unbalanced	(-)	Carbon	(B)	SiC	(Q1)	FPM	(V)	AISI 316	(G)		
HQ1BEG	●	25 bar	+30°C to +140°C	Balanced	(H)	SiC	(Q1)	Carbon	(B)	EPDM	(E)	AISI 316	(G)		
HQ1BVG	○	25 bar	-30°C to +80°C	Balanced	(H)	SiC	(Q1)	Carbon	(B)	FPM	(V)	AISI 316	(G)		
HQgQ1EG	○	25 bar	-30°C to +140°C	Balanced	(H)	SiC with graphite	(Qg)	SiC	(Q1)	EPDM	(E)	AISI 316	(G)		
HQgQ1VG	○	25 bar	-30°C to +80°C	Balanced	(H)	SiC with graphite	(Qg)	SiC	(Q1)	FPM	(V)	AISI 316	(G)		

● Standard ○ On request

Pump model	Shaft seal type		Max operating pressure	d1 [mm]	d2 [mm]	d3 [mm]	d4 [mm]	l [mm]
EVMS 10/5	Cartridge	Unbalanced	16 bar	16	-	23	27	35
		Balanced	25 bar		20			42.5
EVMS 10/15/20	Cartridge	Unbalanced	16 bar	20	-	28	35	37.5
		Balanced	25 bar		24			45

### PERFORMANCE RANGE RESEAU PUMP WITH INVERTER EVMS(.)-K1-3-5

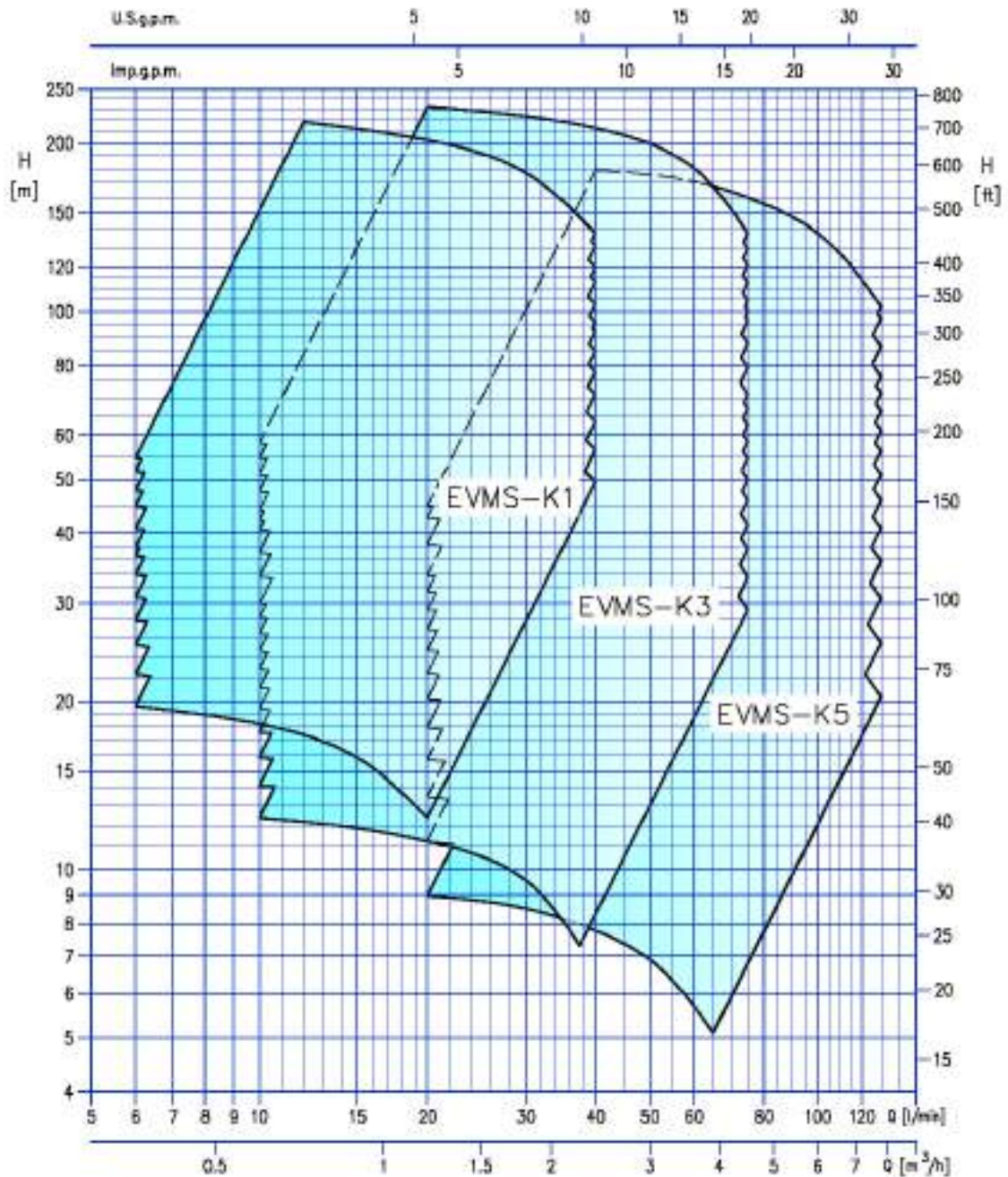

### RESEAU PUMP WITH INVERTER EVMS(.)-K10-15-20

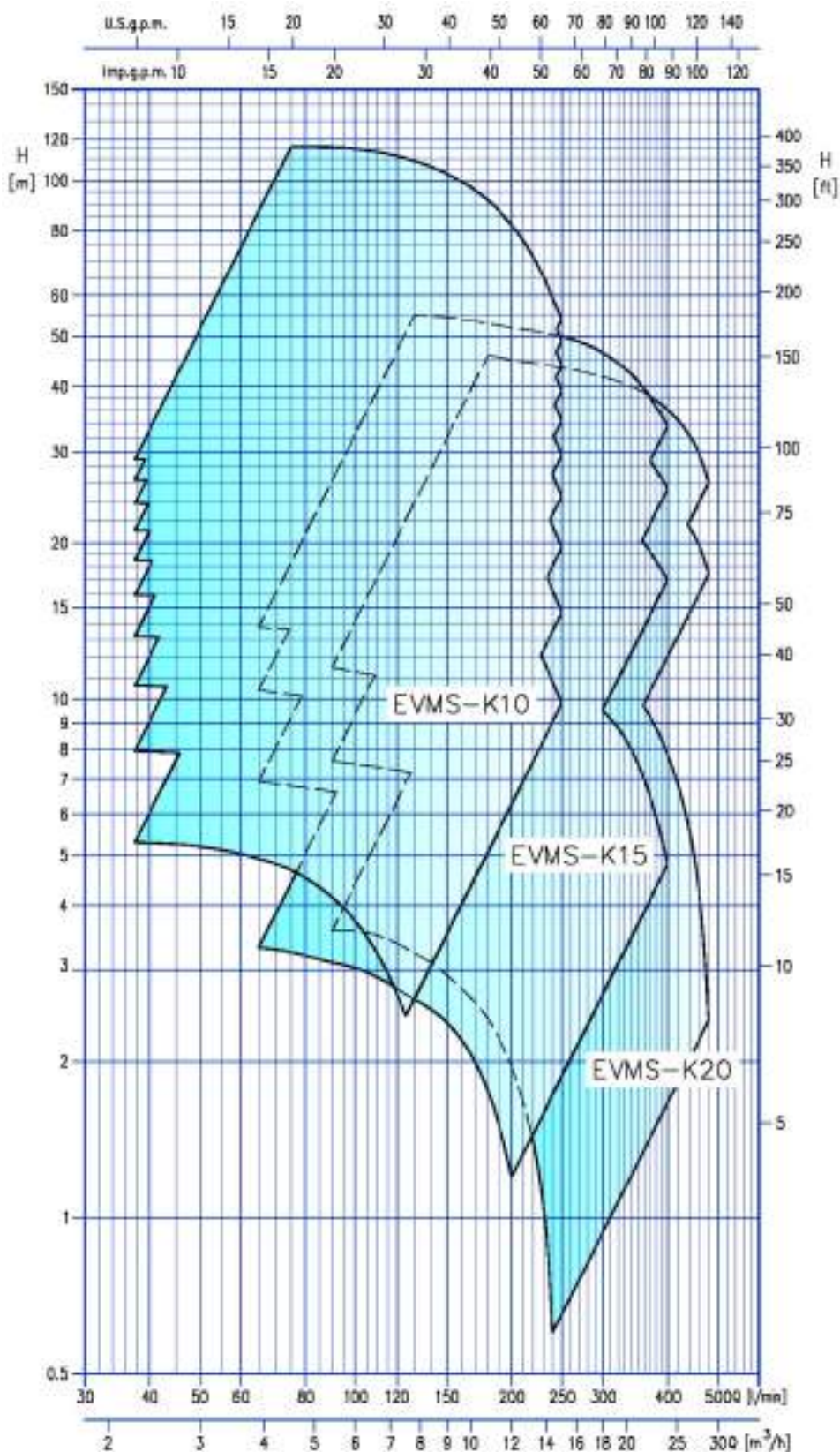

### CURVE SPECIFICATION

The specifications below qualify the curves shown on the following pages.

Tolerances according to ISO 9906:2012 – Grade 3B.

The curves refer to effective speed of asynchronous motors at 50 Hz 2 poles

Measurements were carried out with clean water at 20°C of temperature and with a kinematic viscosity of  $\nu = 1 \text{ mm}^2/\text{s}$  (1 cSt).

The NPSH curve is an average curve obtained in the same conditions of performance curves.

During the pump selection, consider to get a safety margin of at least 0.5 m.

The continuous curves indicate the recommended working range. The dotted curve is only a guide.

In order to avoid the risk of over-heating, the pumps should not be used at a flow rate below 10% of best efficiency point.

Symbols explanation:

- Q = volume flow rate
- H = total head
- P2 = pump power input (shaft power)
- $\eta$  = pump efficiency
- NPSH = net positive suction head required by the pump
- MEI = minimum efficiency index

The minimum efficiency index (MEI) is a measure of the quality of a pump size in respect to its mean efficiency. The minimum efficiency index is based on the hydraulic efficiency and on the head at the best efficiency point.

The efficiency of a pump with trimmed impeller is usually lower than that of a pump with the full impeller diameter. The trimming of the impeller will adapt the pump to a fixed duty point leading to a reduced energy consumption. The minimum efficiency index (MEI) is based on the full impeller diameter.

The operation of these water pumps with variable duty points may be more efficient and economical when controlled, for example by the use of a variable speed drive that matches the pump duty to the system.

Information on benchmark efficiency is available at: [www.europump.org](http://www.europump.org) (Ecodesign section)

Information on benchmark efficiency graph for MEI = 0.7 for the pump are available at: [www.europump.org/efficiencycharts](http://www.europump.org/efficiencycharts) (refer to "Multistage Vertical 2900 rpm")

Minimum efficiency index (MEI)

Pump type	MEI
EVMS(.1)	> 0.70
EVMS(.3)	> 0.70
EVMS(.5)	> 0.70
EVMS(.10)	> 0.70
EVMS(.15)	> 0.70
EVMS(.20)	> 0.70



### SELECTION CHART EVMS(.)-K1-3-5

Model	Supply		Motor		Maximum working pressure (MPa)	Q=Capacity									
	Single phase	Three phase	kW	HP		l/min	0	12	20	30	40	60	75	100	130
						m <sup>3</sup> /h	0	0.7	1.2	1.8	2.4	3.6	4.5	6.0	7.8
						H=Total manometric head in meters									
EVMS(.)-K1 14/0.75	•	•	0.75	1	1.6	83.5	78.5	73.0	63.5	49.5	-	-	-	-	
EVMS(.)-K1 16/0.75	•	•	0.75	1		95.5	89.5	83.0	72.5	56.5	-	-	-	-	
EVMS(.)-K1 18/1.1	•	•	1.1	1.5		2.5	107.0	101.0	93.5	82.0	63.5	-	-	-	-
EVMS(.)-K1 20/1.1	•	•	1.1	1.5			119.0	112.0	104.0	91.0	71.0	-	-	-	-
EVMS(.)-K1 22/1.1	•	•	1.1	1.5			131.0	123.0	114.0	100.0	78.0	-	-	-	-
EVMS(.)-K1 24/1.1	•	•	1.1	1.5			143.0	135.0	125.0	109.0	85.0	-	-	-	-
EVMS(.)-K1 26/1.1	•	•	1.1	1.5			155.0	146.0	135.0	118.0	92.0	-	-	-	-
EVMS(.)-K1 27/1.5	•	•	1.5	2	161.0		151.0	140.0	123.0	95.5	-	-	-	-	
EVMS(.)-K1 29/1.5	•	•	1.5	2	173.0		163.0	151.0	132.0	103.0	-	-	-	-	
EVMS(.)-K1 32/1.5	•	•	1.5	2	191.0		179.0	166.0	145.0	113.0	-	-	-	-	
EVMS(.)-K1 34/1.5	•	•	1.5	2	203.0		191.0	177.0	155.0	120.0	-	-	-	-	
EVMS(.)-K1 37/2.2	•	•	2.2	3	221		207.0	192.0	168.0	131.0	-	-	-	-	
EVMS(.)-K1 39/2.2	•	•	2.2	3	232	219.0	203.0	177.0	138.0	-	-	-	-		
EVMS(.)-K3 7/0.75	•	•	0.75	1	1.6	51.5	-	49.5	47.5	45.0	38.3	29.2	-	-	
EVMS(.)-K3 8/0.75	•	•	0.75	1		59.0	-	56.5	54.5	51.5	44.0	33.4	-	-	
EVMS(.)-K3 9/1.1	•	•	1.1	1.5		66.5	-	63.5	61.0	58.0	49.0	37.6	-	-	
EVMS(.)-K3 10/1.1	•	•	1.1	1.5		73.5	-	70.5	68.0	64.5	54.5	41.5	-	-	
EVMS(.)-K3 11/1.1	•	•	1.1	1.5		81.0	-	77.5	74.5	71.0	60.0	46.0	-	-	
EVMS(.)-K3 12/1.1	•	•	1.1	1.5		88.5	-	84.5	81.5	77.5	65.5	50.0	-	-	
EVMS(.)-K3 13/1.5	•	•	1.5	2		96.0	-	91.5	88.0	84.0	71.0	54.5	-	-	
EVMS(.)-K3 14/1.5	•	•	1.5	2		103.0	-	98.5	95.0	90.5	76.5	58.5	-	-	
EVMS(.)-K3 15/1.5	•	•	1.5	2		111.0	-	106.0	102.0	97.0	82.0	62.5	-	-	
EVMS(.)-K3 16/1.5	•	•	1.5	2		118.0	-	113.0	109.0	103.0	87.5	67.0	-	-	
EVMS(.)-K3 17/2.2	•	•	2.2	3		125.0	-	120.0	115.0	110.0	93.0	71.0	-	-	
EVMS(.)-K3 19/2.2	•	•	2.2	3		140.0	-	134.0	129.0	123.0	104.0	79.5	-	-	
EVMS(.)-K3 21/2.2	•	•	2.2	3		155.0	-	148.0	142.0	136.0	115.0	87.5	-	-	
EVMS(.)-K3 23/2.2	•	•	2.2	3		170.0	-	162.0	156.0	149.0	126.0	96.0	-	-	
EVMS(.)-K3 24/2.2	•	•	2.2	3		177.0	-	169.0	163.0	155.0	131.0	100.0	-	-	
EVMS(.)-K3 25/3.0	-	•	3.0	4		184.0	-	176.0	170.0	161.0	137.0	104.0	-	-	
EVMS(.)-K3 27/3.0	-	•	3.0	4		199.0	-	190.0	183.0	174.0	148.0	113.0	-	-	
EVMS(.)-K3 29/3.0	-	•	3.0	4	214.0	-	204.0	197.0	187.0	159.0	121.0	-	-		
EVMS(.)-K3 31/3.0	-	•	3.0	4	229	-	218.0	210.0	200.0	170.0	129.0	-	-		
EVMS(.)-K3 33/3.0	-	•	3.0	4	243	-	232.0	224.0	213.0	181.0	138.0	-	-		
EVMS(.)-K5 4/0.75	•	•	0.75	1	1.6	37.9	-	-	-	35.9	34.1	31.9	27.6	20.4	
EVMS(.)-K5 5/1.1	•	•	1.1	1.5		47.5	-	-	-	45.0	42.5	39.9	34.5	25.5	
EVMS(.)-K5 6/1.5	•	•	1.5	2		57.0	-	-	-	54.0	51.0	48.0	41.5	30.6	
EVMS(.)-K5 7/1.5	•	•	1.5	2		66.5	-	-	-	63.0	59.5	56.0	48.5	35.7	
EVMS(.)-K5 8/2.2	•	•	2.2	3		76.0	-	-	-	72.0	68.0	64.0	55.0	41.0	
EVMS(.)-K5 9/2.2	•	•	2.2	3		85.5	-	-	-	81.0	77.0	72.0	62.0	46.0	
EVMS(.)-K5 10/2.2	•	•	2.2	3		95.0	-	-	-	90.0	85.5	80.0	69.0	51.0	
EVMS(.)-K5 11/2.2	•	•	2.2	3		104.0	-	-	-	98.5	94.0	87.5	76.0	56.0	
EVMS(.)-K5 12/3.0	-	•	3.0	4		114.0	-	-	-	108.0	102.0	95.5	83.0	61.0	
EVMS(.)-K5 13/3.0	-	•	3.0	4		123.0	-	-	-	117.0	111.0	104.0	89.5	66.5	
EVMS(.)-K5 14/3.0	-	•	3.0	4		133.0	-	-	-	126.0	119.0	112.0	96.5	71.5	
EVMS(.)-K5 15/3.0	-	•	3.0	4		142.0	-	-	-	135.0	128.0	120.0	104.0	76.5	
EVMS(.)-K5 17/4.0	-	•	4.0	5.5		161.0	-	-	-	153.0	145.0	136.0	117.0	86.5	
EVMS(.)-K5 19/4.0	-	•	4.0	5.5	2.5	180	-	-	-	171.0	162.0	152.0	131.0	97.0	
EVMS(.)-K5 20/4.0	-	•	4.0	5.5		190	-	-	-	179.0	171.0	160.0	138.0	102.0	

• : Standard    ◦ : On request

### SELECTION CHART EVMS(.)-K10-15-20

Model	Supply		Motor		Maximum working pressure (MPa)	Q=Capacity												
	Single phase	Three phase	kW	HP		I/min	75	100	130	150	180	200	250	300	350	400	450	480
						m <sup>3</sup> /h	4.5	6.0	7.8	9.0	10.8	12.0	15.0	18.0	21.0	24.0	27.0	28.8
H=Total manometric head in meters																		
EVMS(.)-K10 2/0.75	●	●	0.75	1	1.6	21.8	21.2	20.8	19.7	18.7	16.6	14.9	9.8	-	-	-	-	
EVMS(.)-K10 3/1.5	●	●	1.5	2		33	31.8	31.2	29.6	28.0	24.9	22.4	14.7	-	-	-	-	
EVMS(.)-K10 4/2.2	●	●	2.2	3		43.6	42.4	41.7	39.5	37.3	33.2	29.8	19.6	-	-	-	-	
EVMS(.)-K10 5/2.2	●	●	2.2	3		54.5	53.0	52.0	49.3	46.7	41.5	37.3	24.6	-	-	-	-	
EVMS(.)-K10 6/2.2	●	●	2.2	3		65.5	63.5	62.5	59.0	56.0	50.0	45.0	29.5	-	-	-	-	
EVMS(.)-K10 7/3.0	-	●	3.0	4		76.5	74.0	73.0	69.0	65.5	58.0	52.0	34.4	-	-	-	-	
EVMS(.)-K10 8/3.0	-	●	3.0	4		87.0	84.5	83.5	79.0	74.5	66.5	59.5	39.3	-	-	-	-	
EVMS(.)-K10 9/4.0	-	●	4.0	5.5		98.0	95.5	93.5	89.0	84.0	74.5	67.0	44.0	-	-	-	-	
EVMS(.)-K10 10/4.0	-	●	4.0	5.5		109.0	106.0	104.0	98.5	93.5	83.0	74.5	49.0	-	-	-	-	
EVMS(.)-K10 11/4.0	-	●	4.0	5.5		120.0	116.0	115.0	109.0	103.0	91.5	82.0	54.0	-	-	-	-	
EVMS(.)-K15 1/1.1	●	●	1.1	1.5	1.6	14.9	-	-	13.3	13.0	12.4	12.1	10.8	9.5	7.5	4.8	-	
EVMS(.)-K15 2/2.2	●	●	2.2	3		30	-	-	27.5	27.1	26.0	26.1	24.9	23.1	20.4	16.8	-	
EVMS(.)-K15 3/3.0	-	●	3	4		44.5	-	-	41.5	40.5	39.7	39.1	37.3	34.7	30.6	25.2	-	
EVMS(.)-K15 4/4.0	-	●	4	5.5		59.0	-	-	55.0	54.5	53.0	52.0	50.0	46.5	41.0	33.6	-	
EVMS(.)-K20 1/1.5	-	●	1.5	2	1.6	17.2	-	-	-	-	14.3	13.9	12.8	11.3	9.6	7.3	4.3	
EVMS(.)-K20 2/3.0	-	●	3.0	4		33.7	-	-	-	-	30.4	29.9	28.9	27.7	26.2	23.6	19.9	
EVMS(.)-K20 3/4.0	-	●	4.0	5.5		50.5	-	-	-	-	46.0	45.0	43.4	41.6	39.2	35.5	29.9	

● : Standard ○ : On request

### PERFORMANCE CURVE EVMS(.)K1-3-5 EVMS(.)-K1 14/0.75

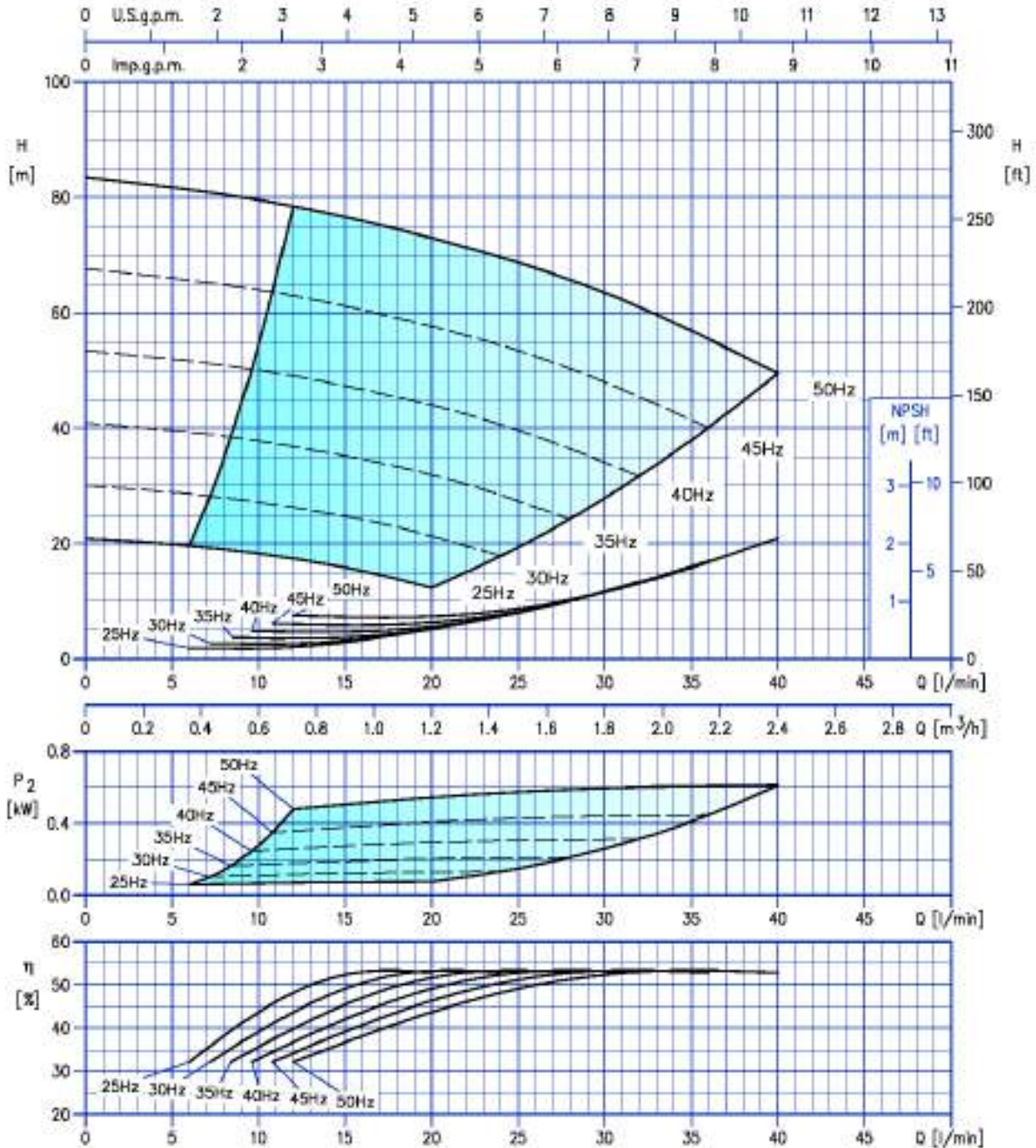

Test standard: ISO 9906: 2012 - Grade 3B

701

### EVMS(.)-K1 16/0.75

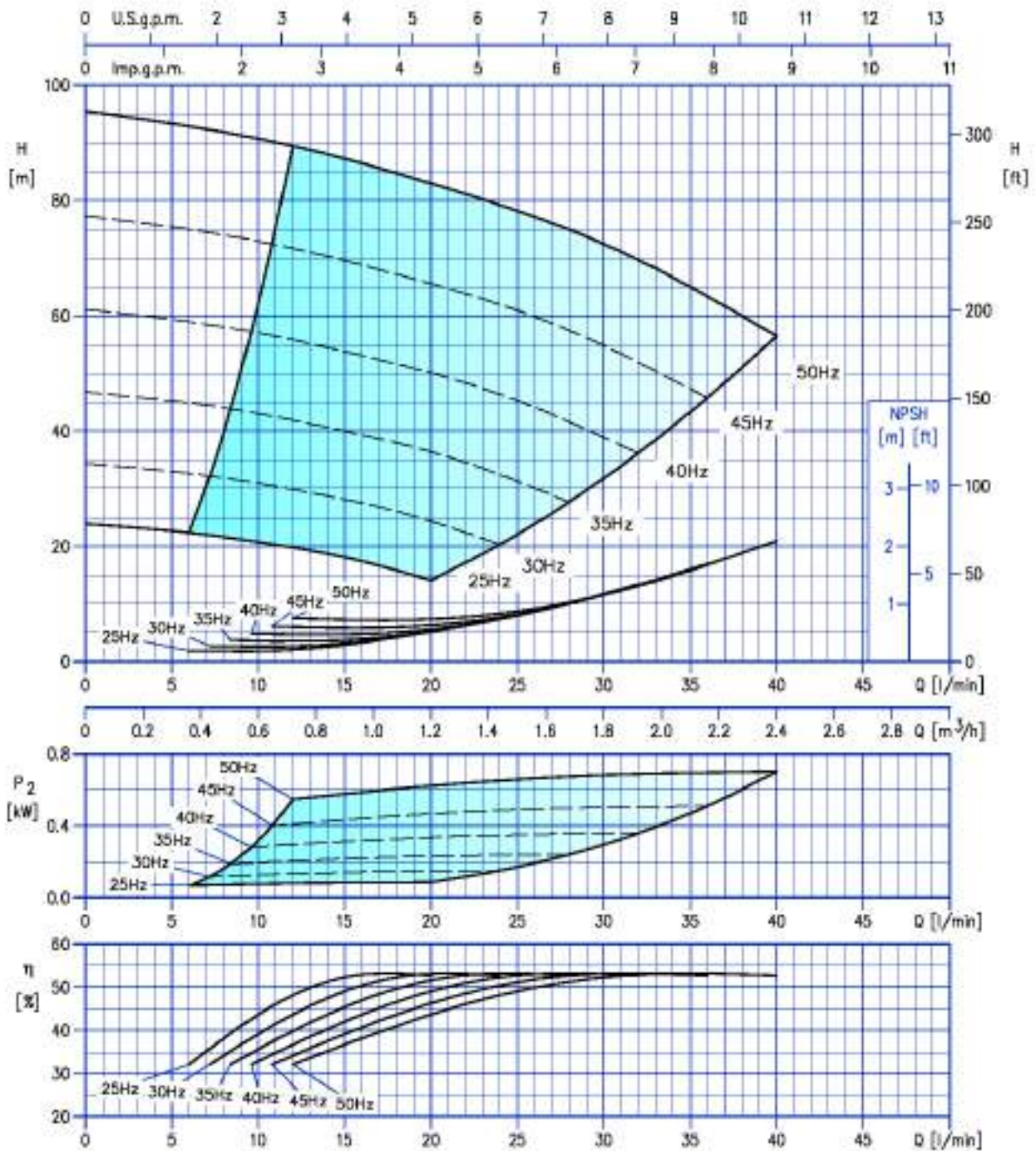

Test standard: ISO 9906: 2012 - Grade 3B

702

### EVMS(.)-K1 18/1.1

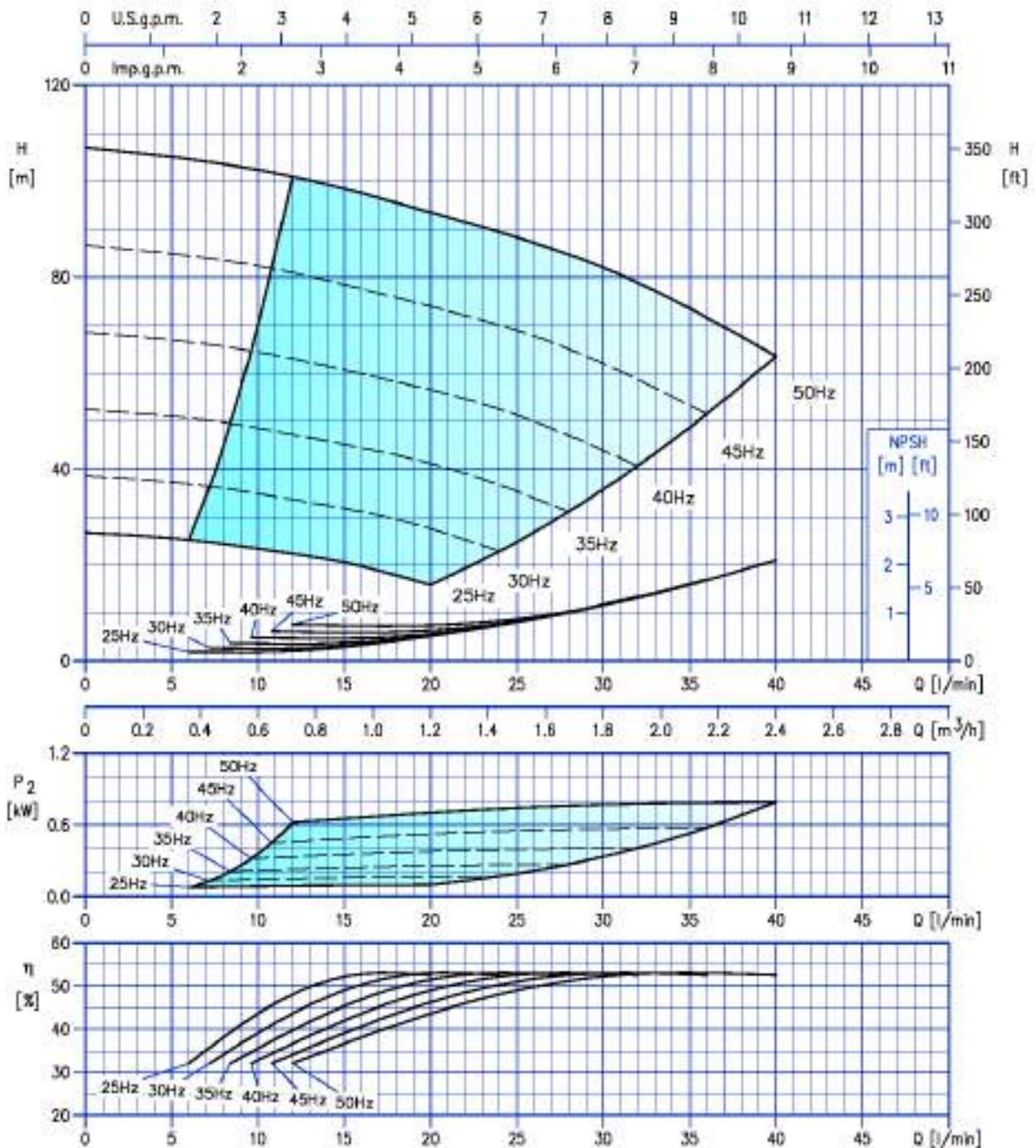

Test standard: ISO 9906: 2012 - Grade 3B

### EVMS(.)-K1 20/1.1

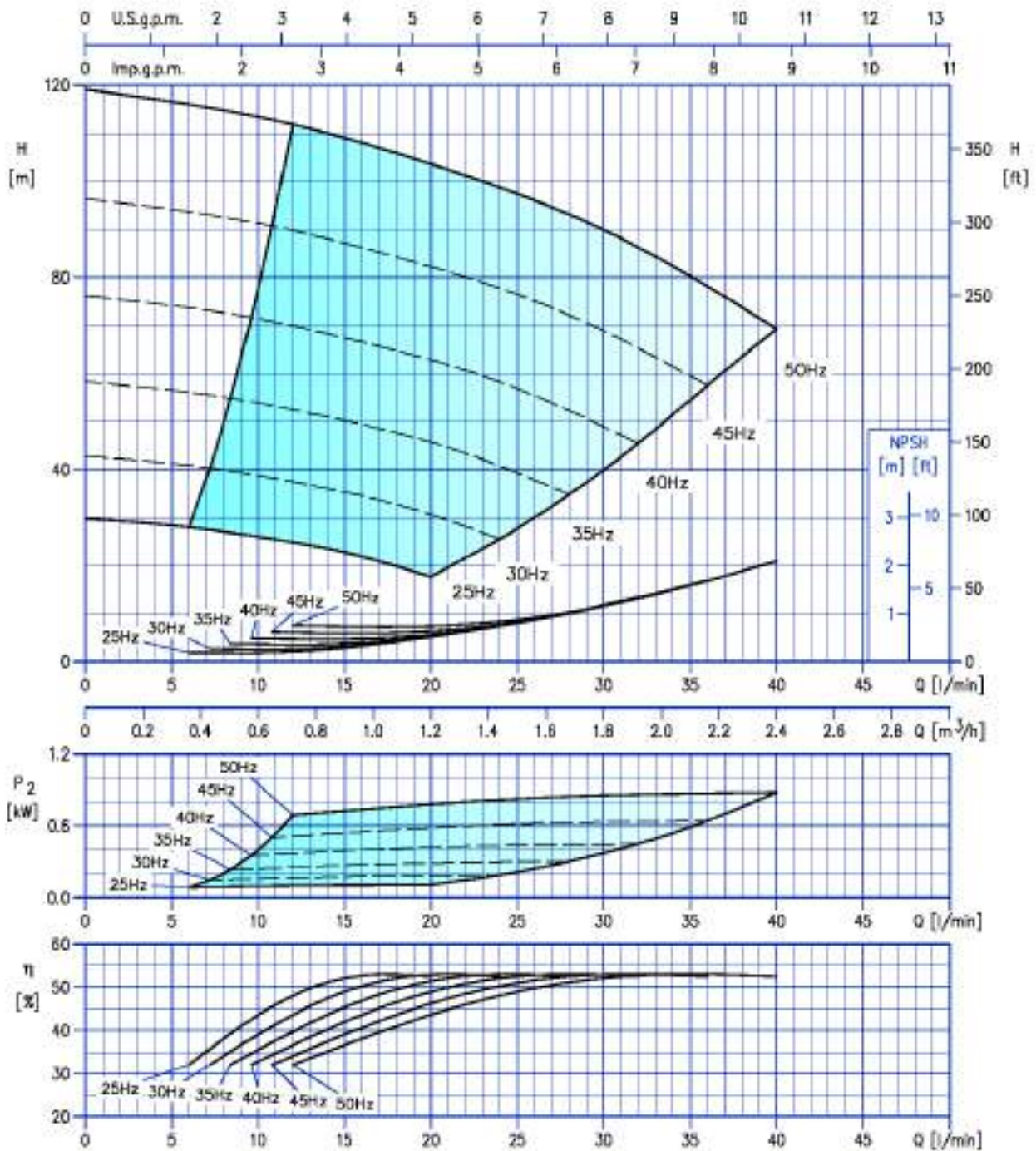

Test standard: ISO 9906: 2012 - Grade 3B

EVMS(.)-K1 22/1.1

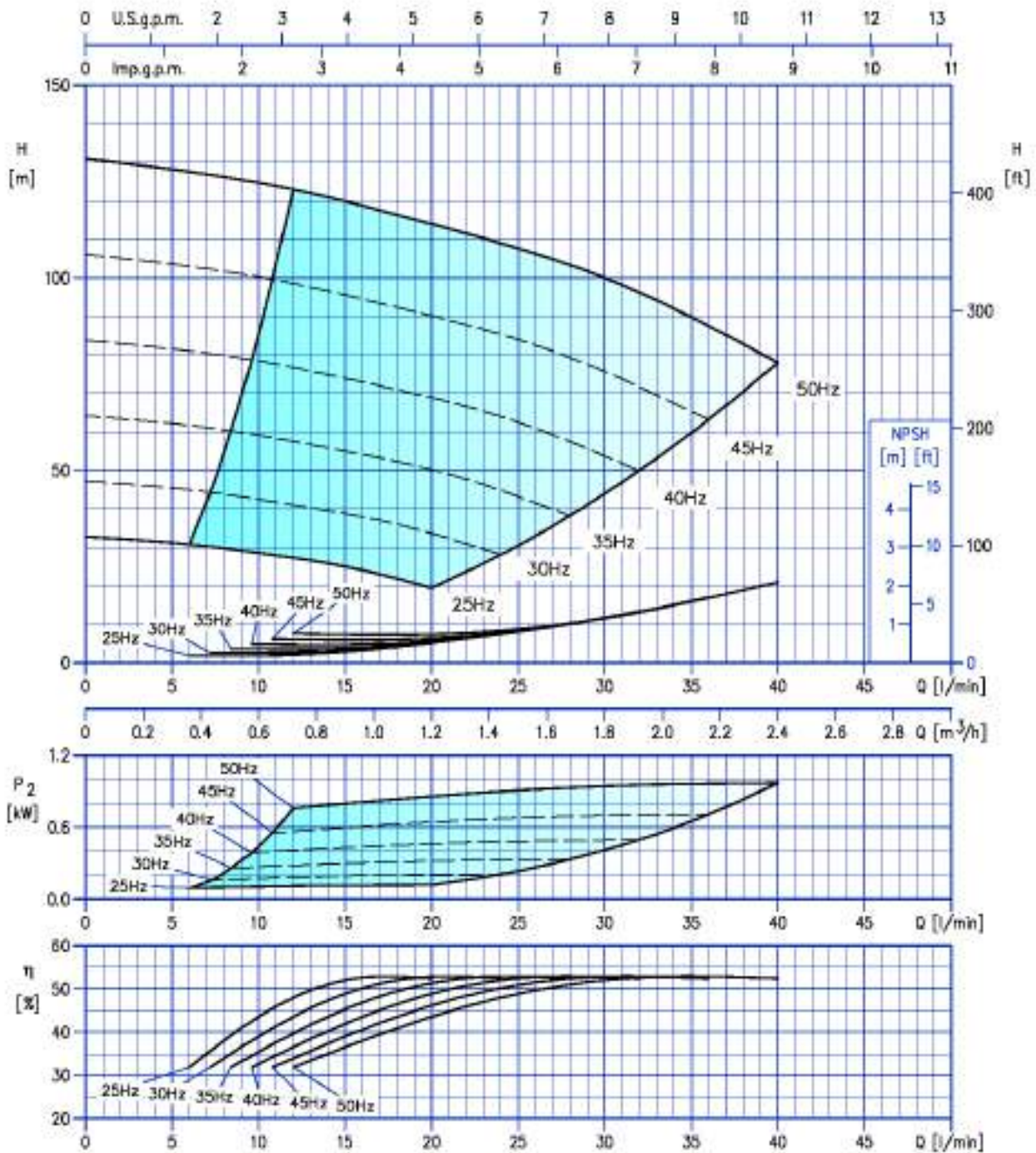

Test standard: ISO 9906: 2012 - Grade 3B

705

### EVMS(.)-K1 24/1.1

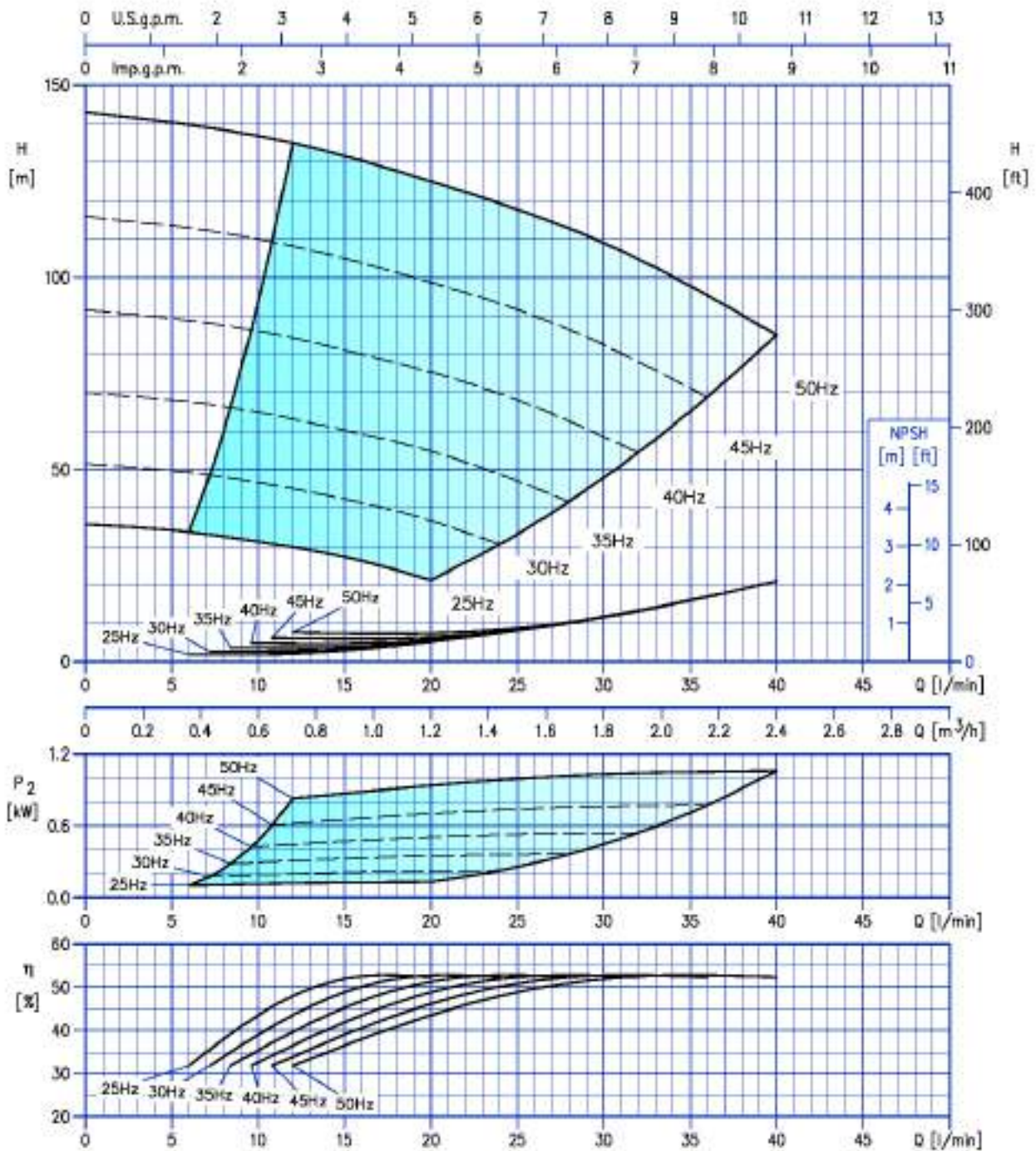

Test standard: ISO 9906: 2012 - Grade 3B

706



### EVMS(.)-K1 26/1.1

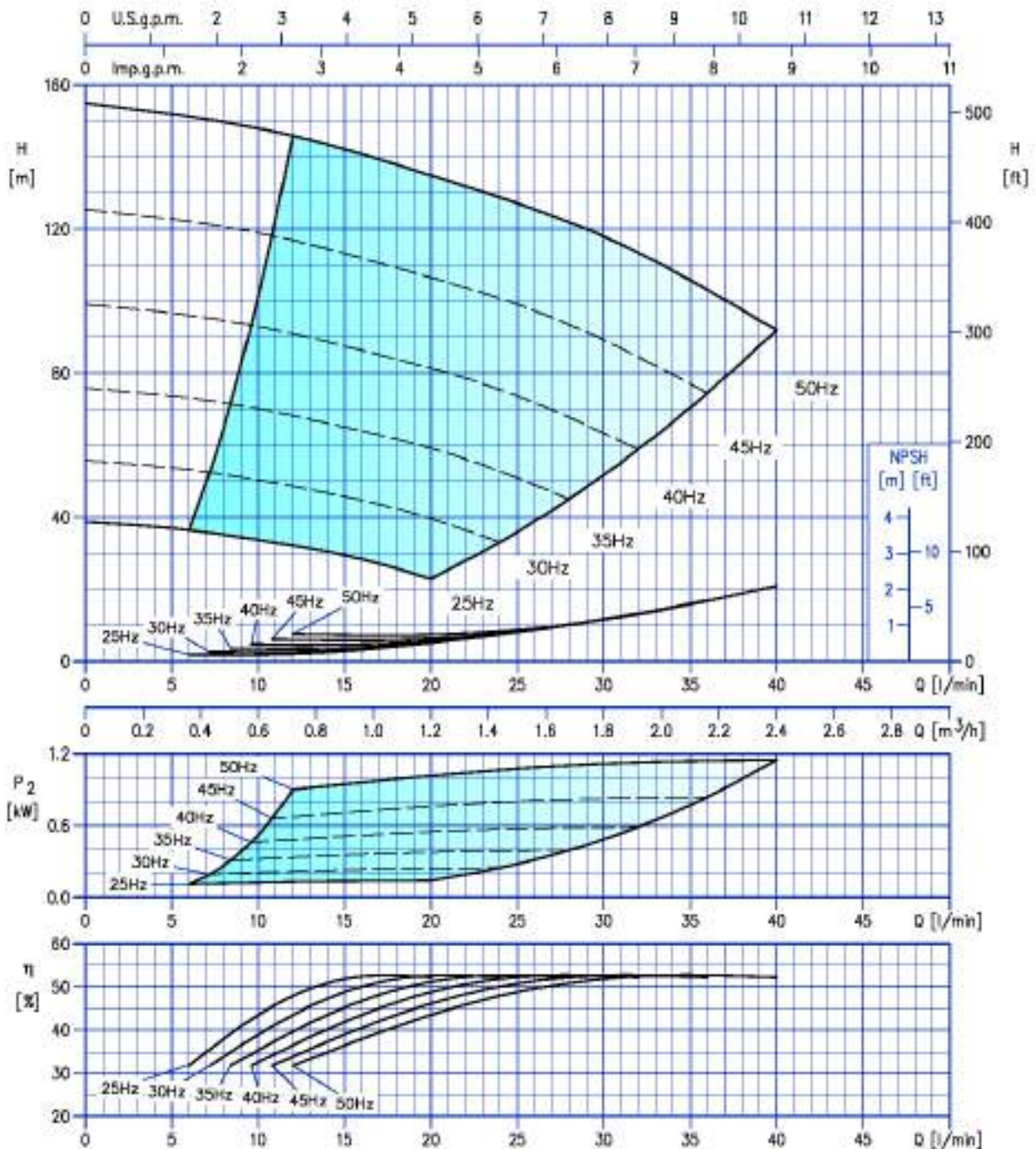

Test standard: ISO 9906: 2012 - Grade 3B

707

### EVMS(.)-K1 27/1.5

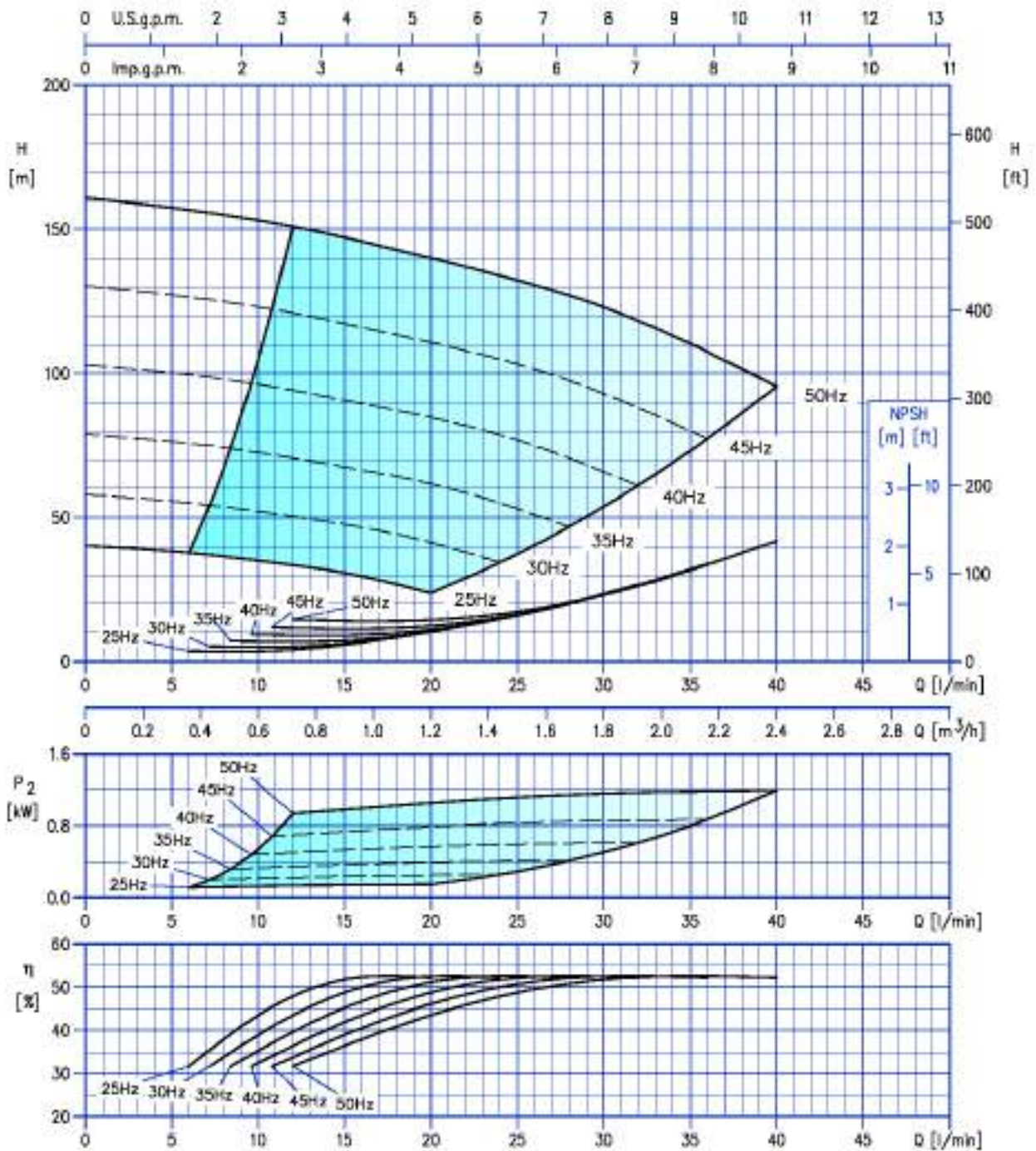

Test standard: ISO 9906: 2012 - Grade 3B

708

### EVMS(.)-K1 29/1.5

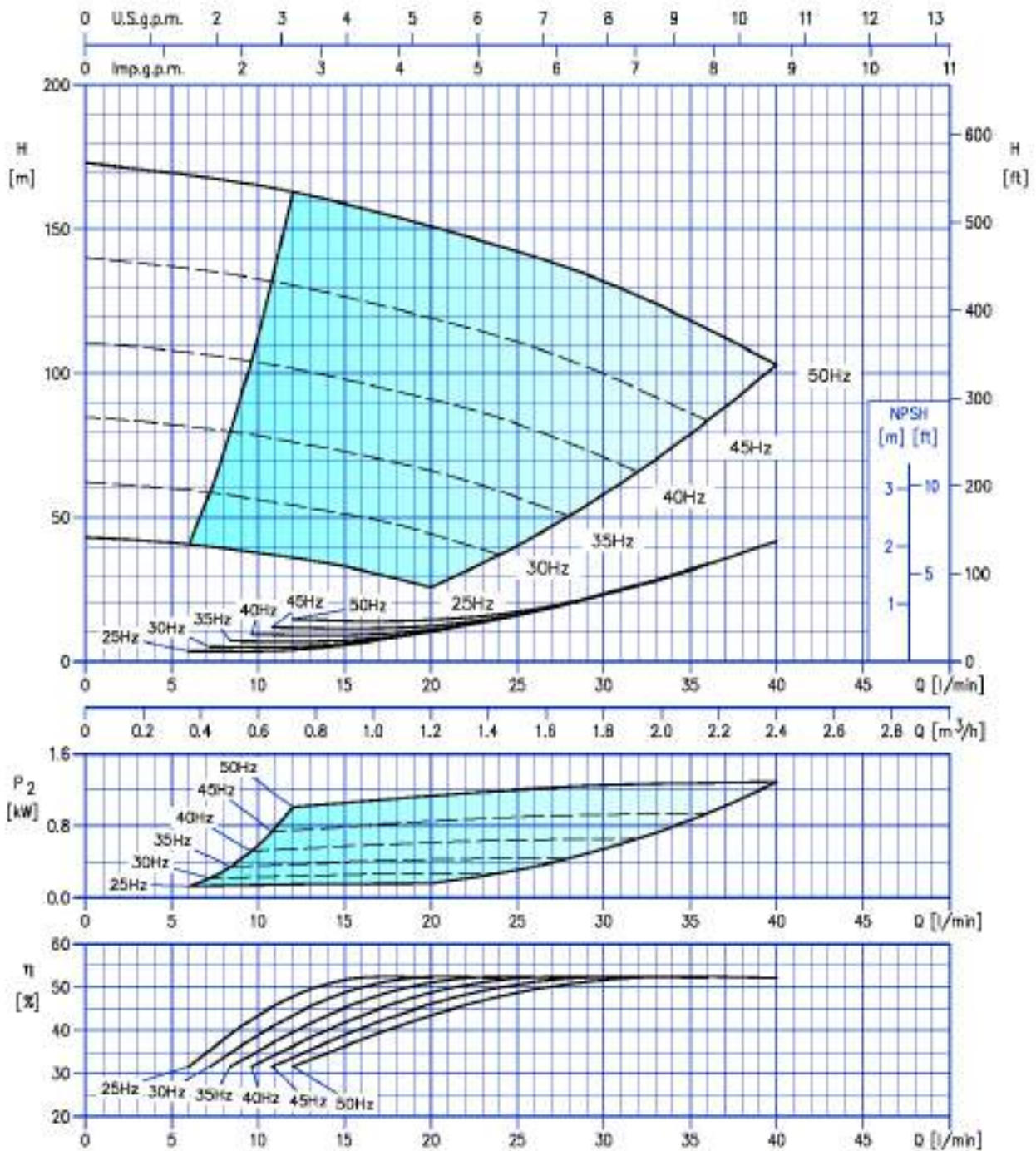

Test standard: ISO 9906: 2012 - Grade 3B

709

### EVMS(.)-K1 32/1.5

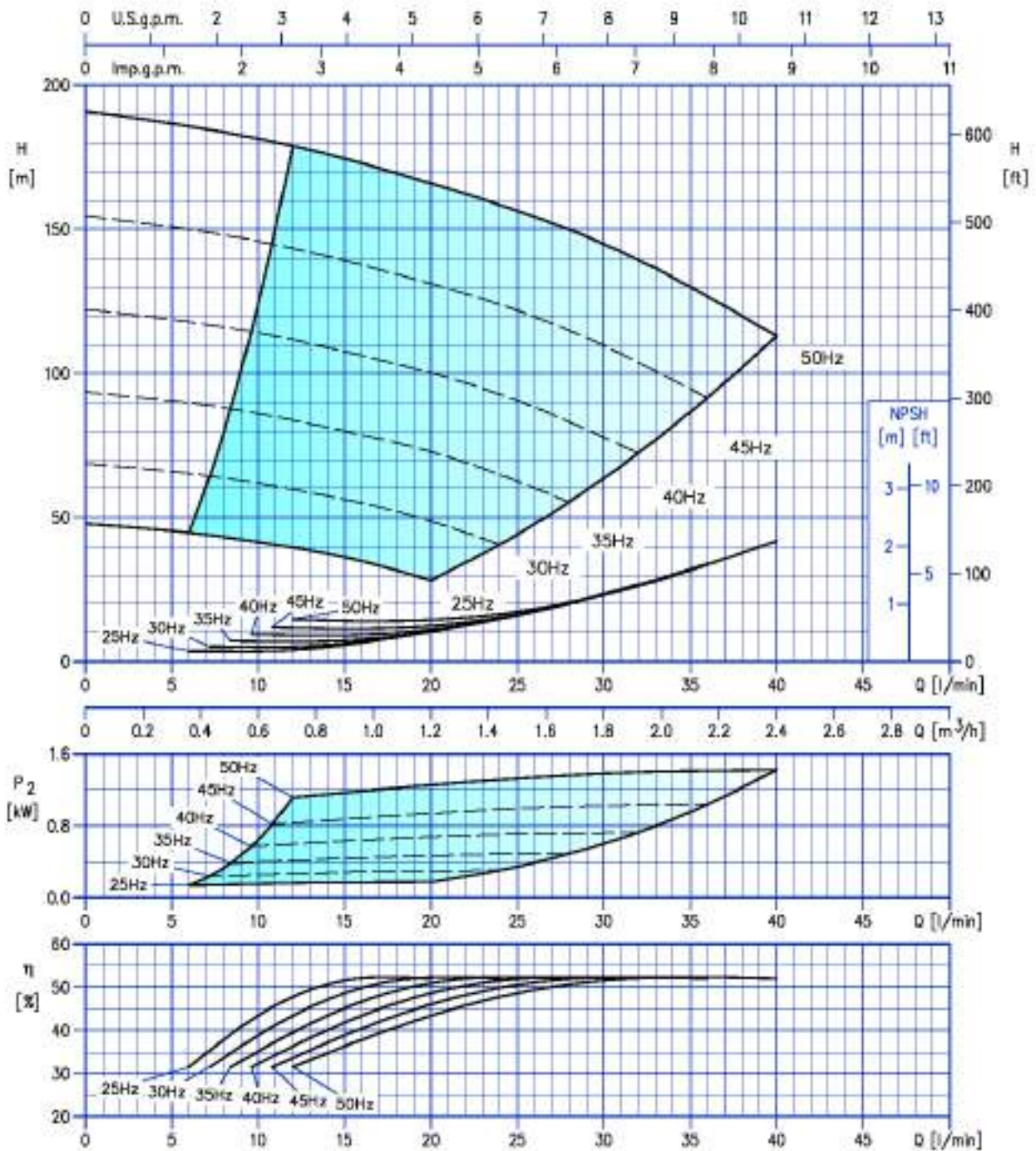

Test standard: ISO 9906: 2012 - Grade 3B

710

### EVMS(.)-K1 34/1.5

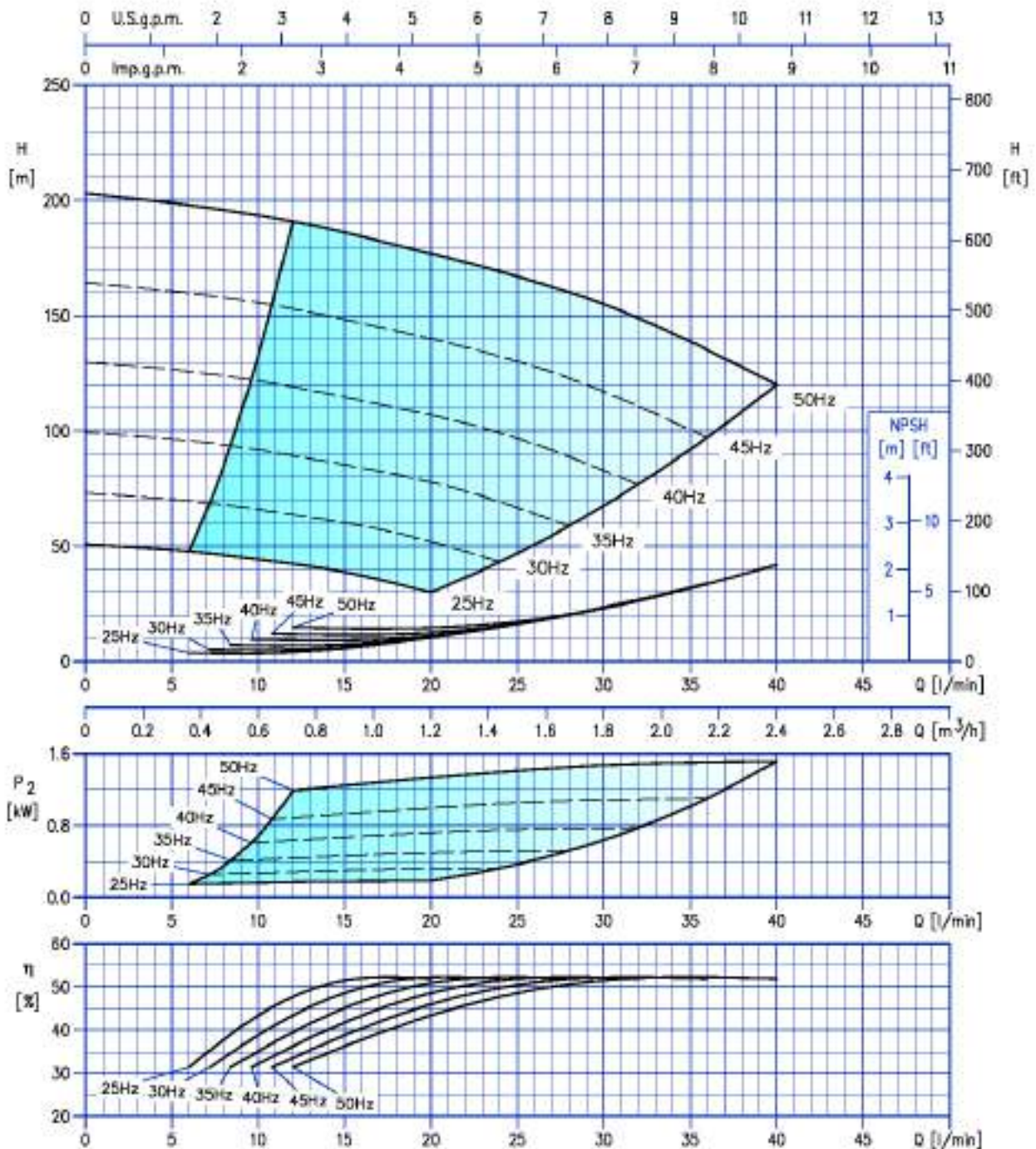

Test standard: ISO 9906: 2012 - Grade 3B

### EVMS(.)-K1 37/2.2

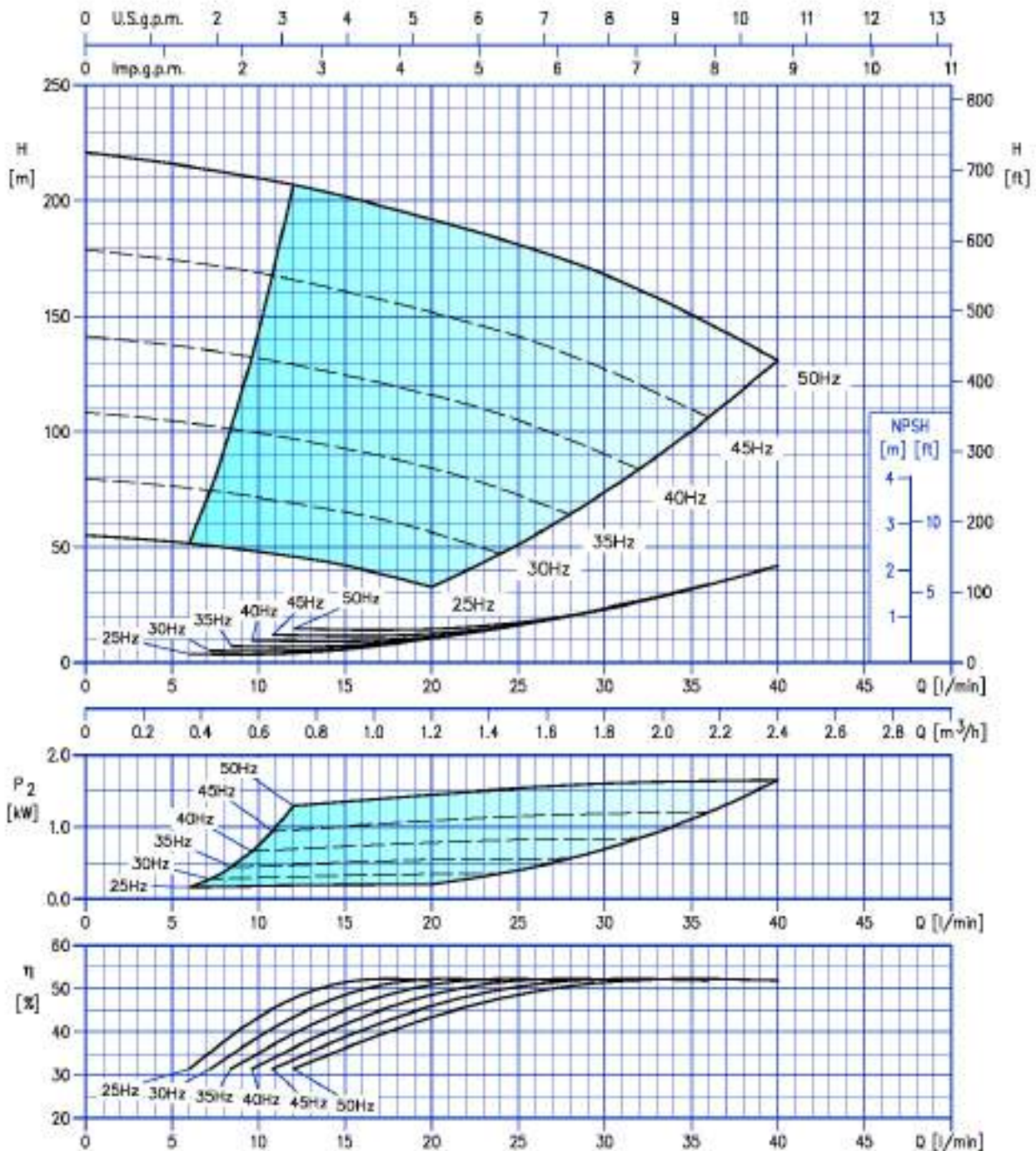

Test standard: ISO 9906: 2012 - Grade 3B

712

### EVMS(.)-K1 39/2.2

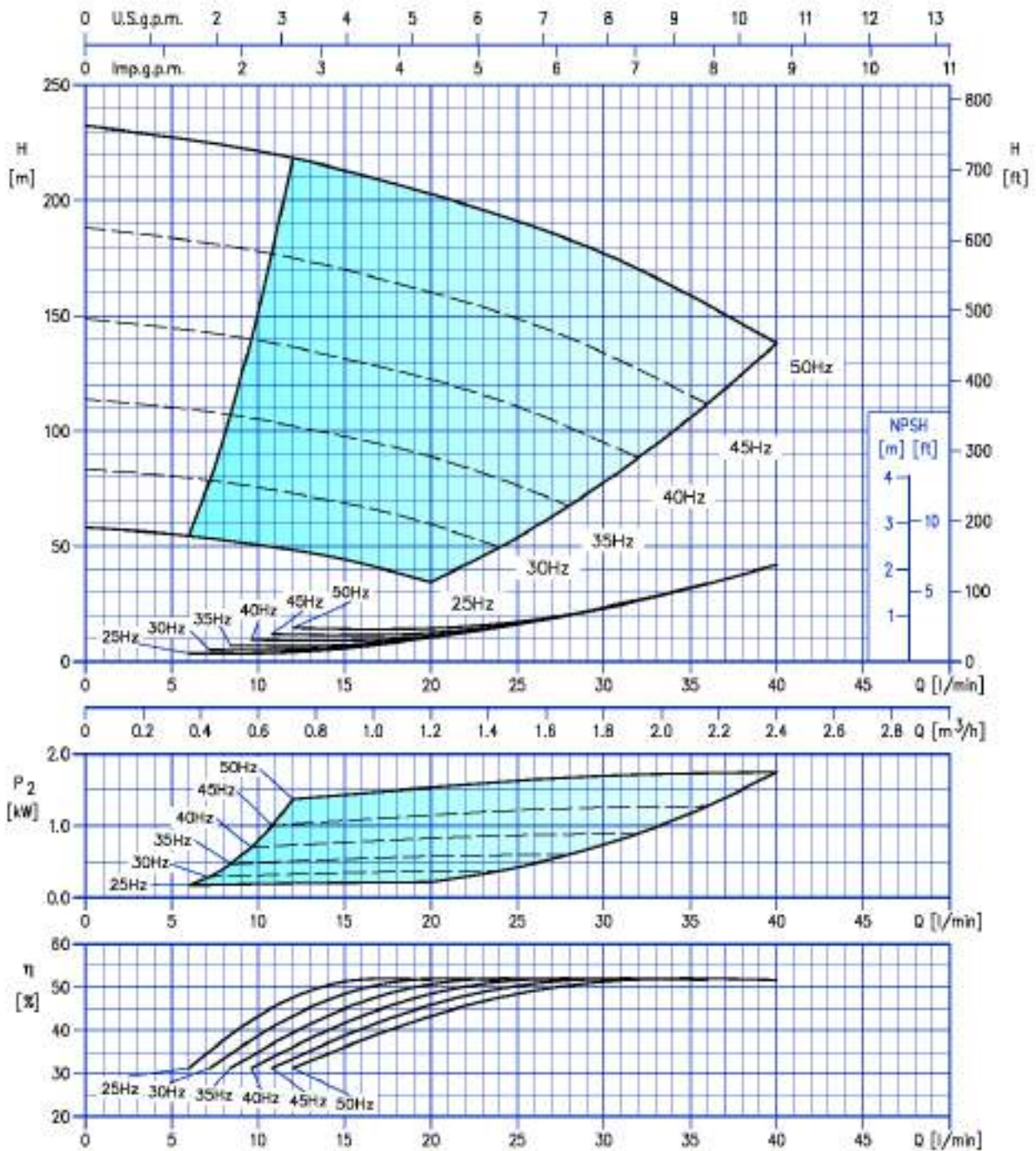

Test standard: ISO 9906: 2012 - Grade 3B

### EVMS(.)-K3 7/0.75

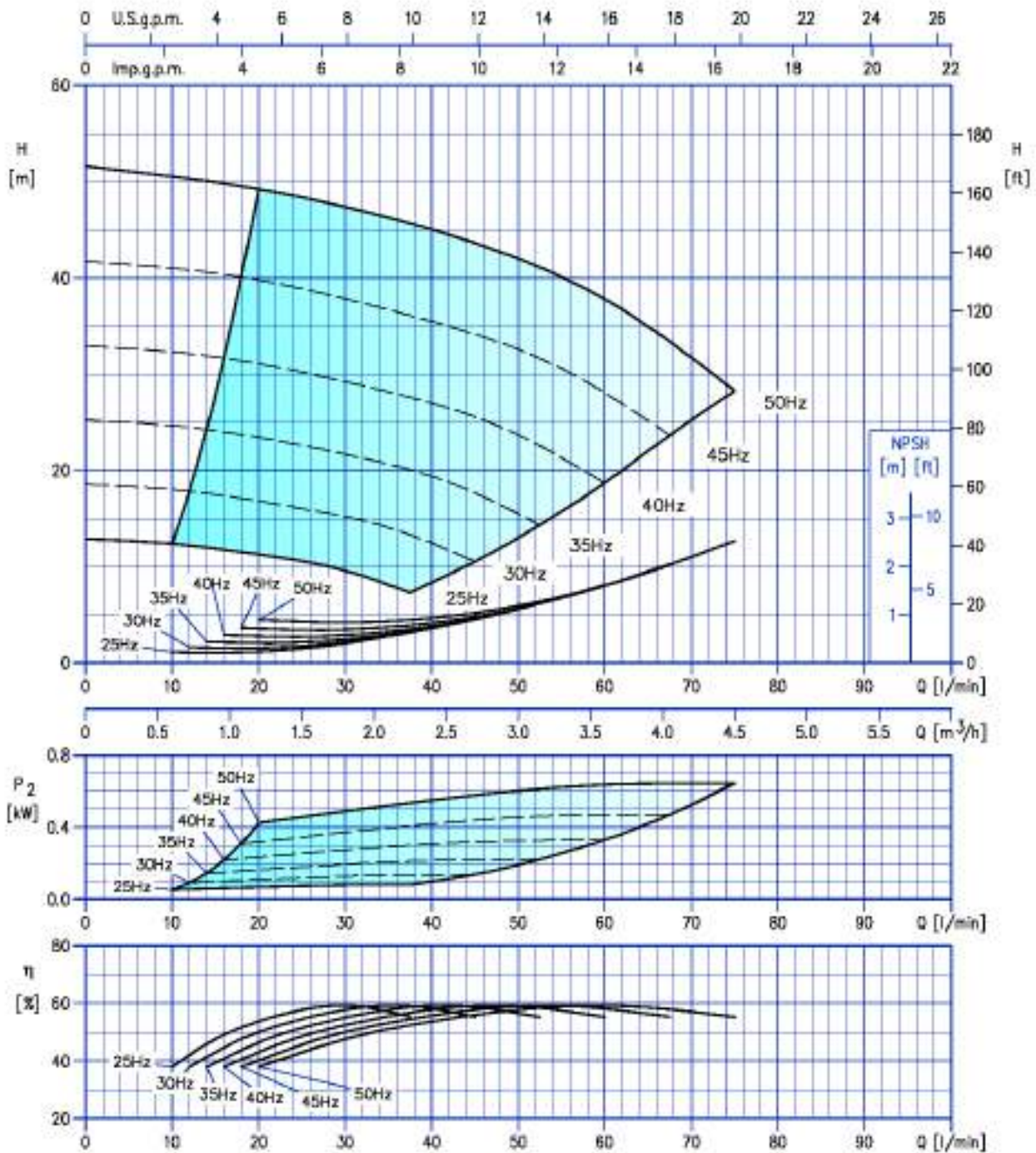

Test standard: ISO 9906: 2012 - Grade 3B

714



### EVMS(.)-K3 8/0.75

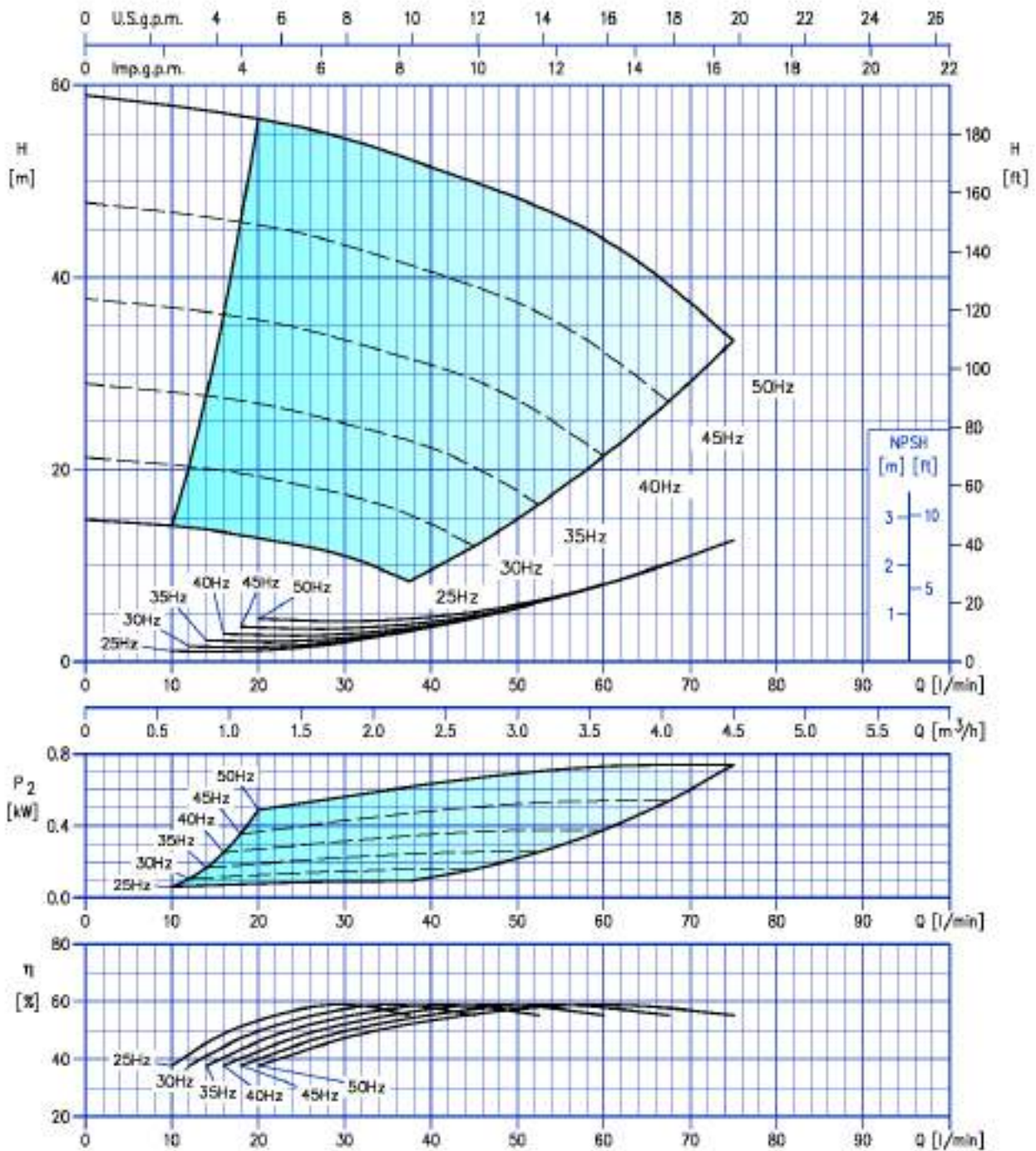

Test standard: ISO 9906: 2012 - Grade 3B

715

### EVMS(.)-K3 9/1.1

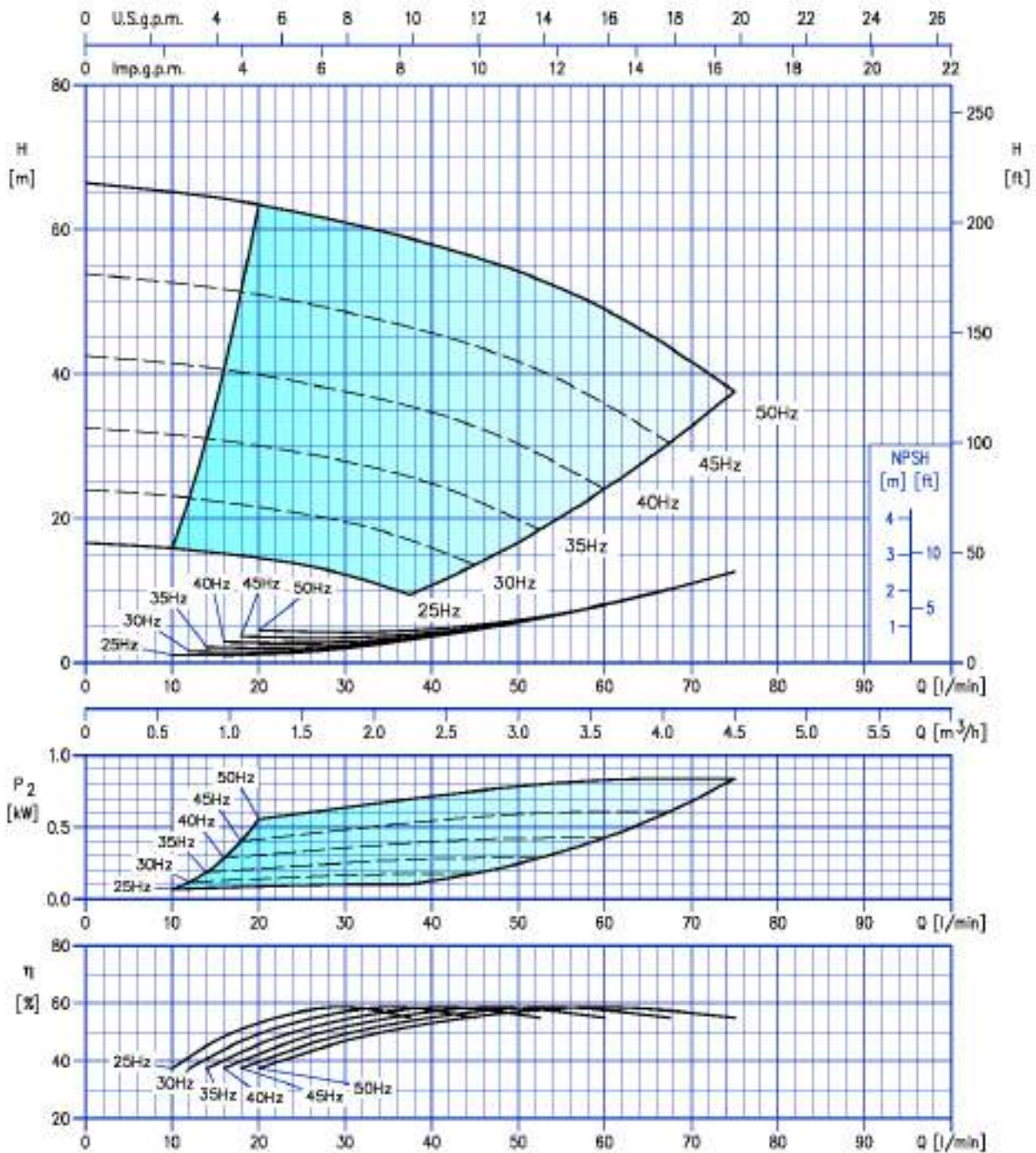

Test standard: ISO 9906: 2012 - Grade 3B

716

### EVMS(.)-K3 10/1.1

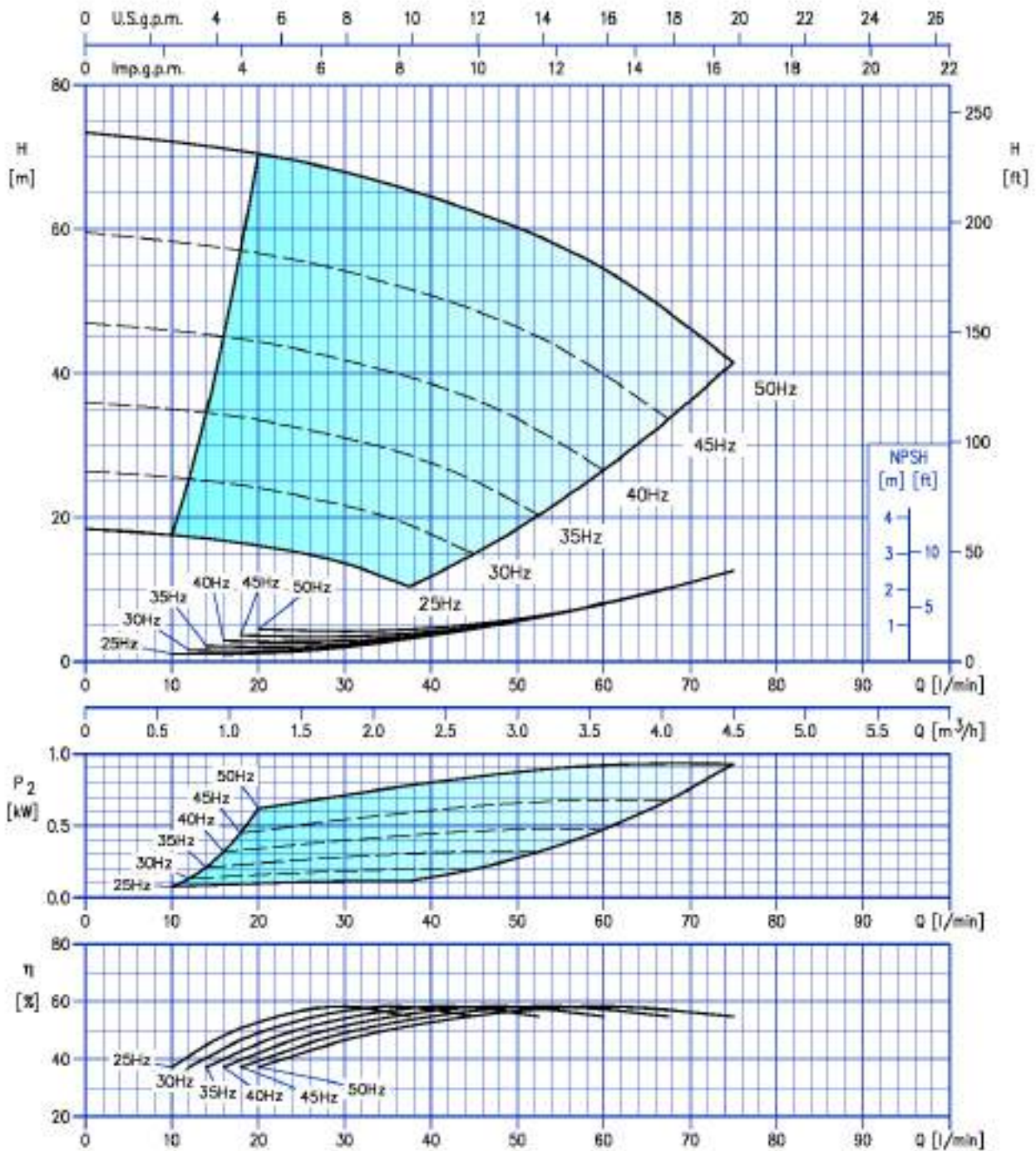

Test standard: ISO 9906: 2012 - Grade 3B

717

### EVMS(.)-K3 11/1.1

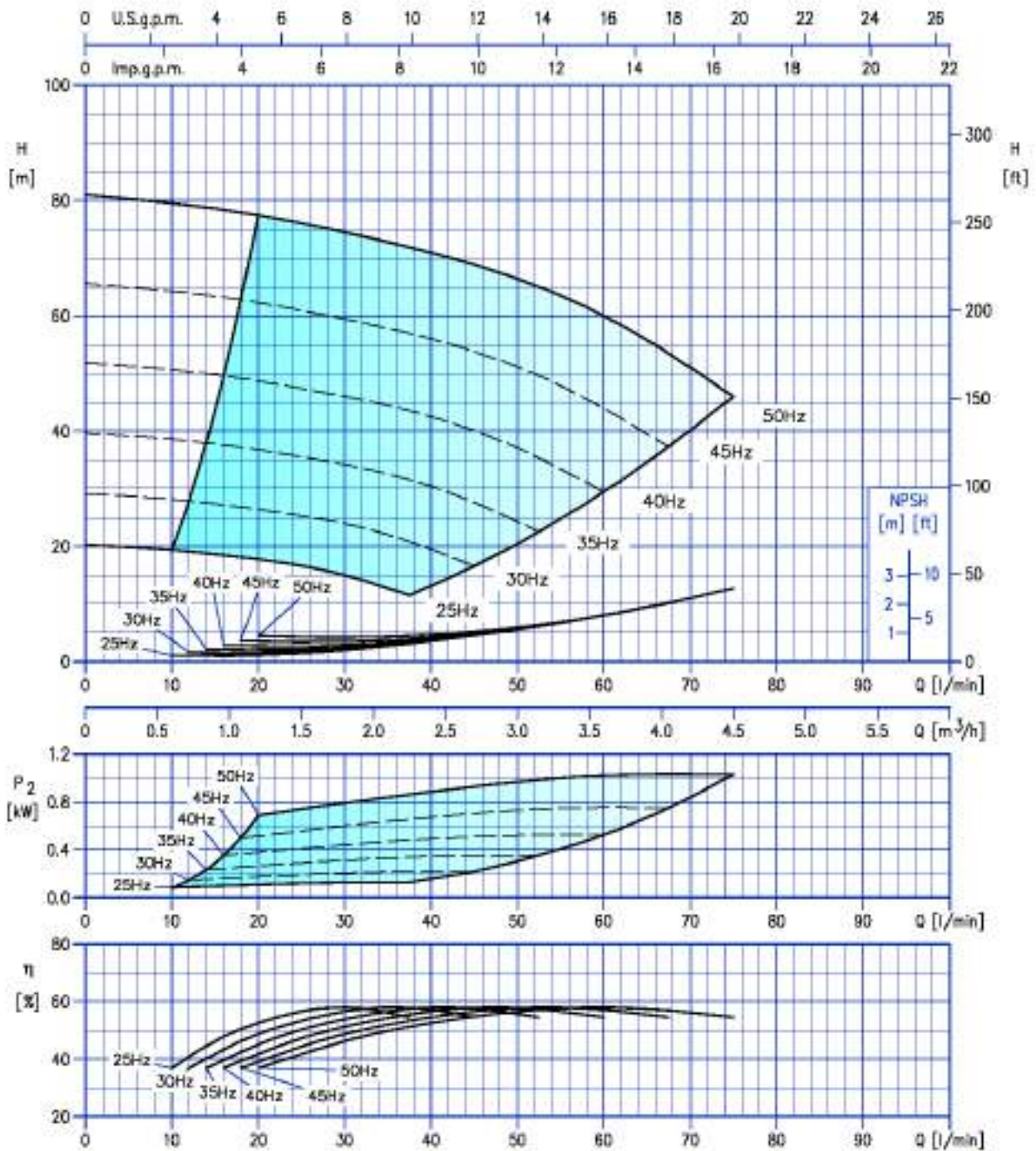

Test standard: ISO 9906: 2012 - Grade 3B

**718**

### EVMS(.)-K3 12/1.1

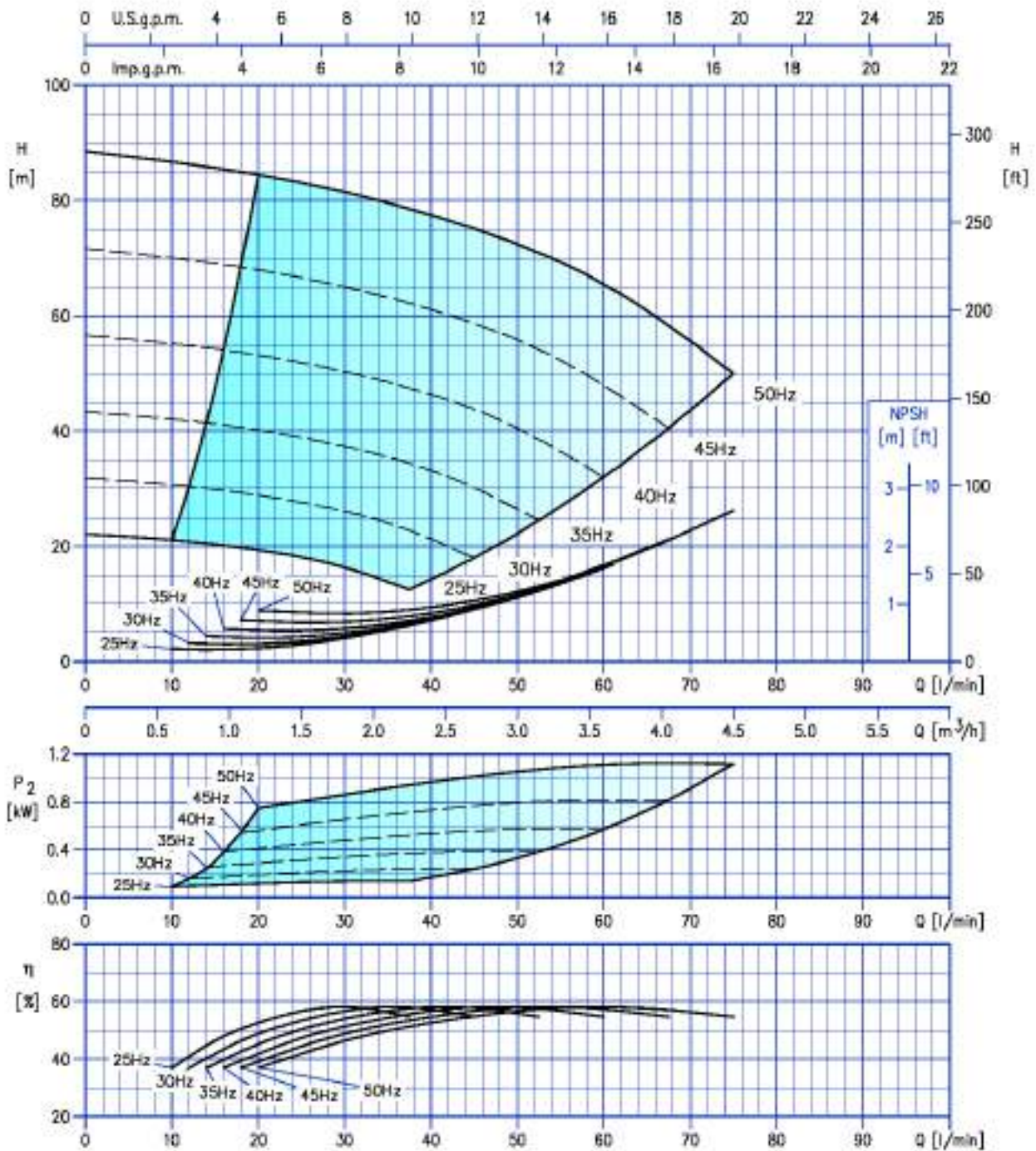

Test standard: ISO 9906: 2012 - Grade 3B

719

### EVMS(.)-K3 13/1.5

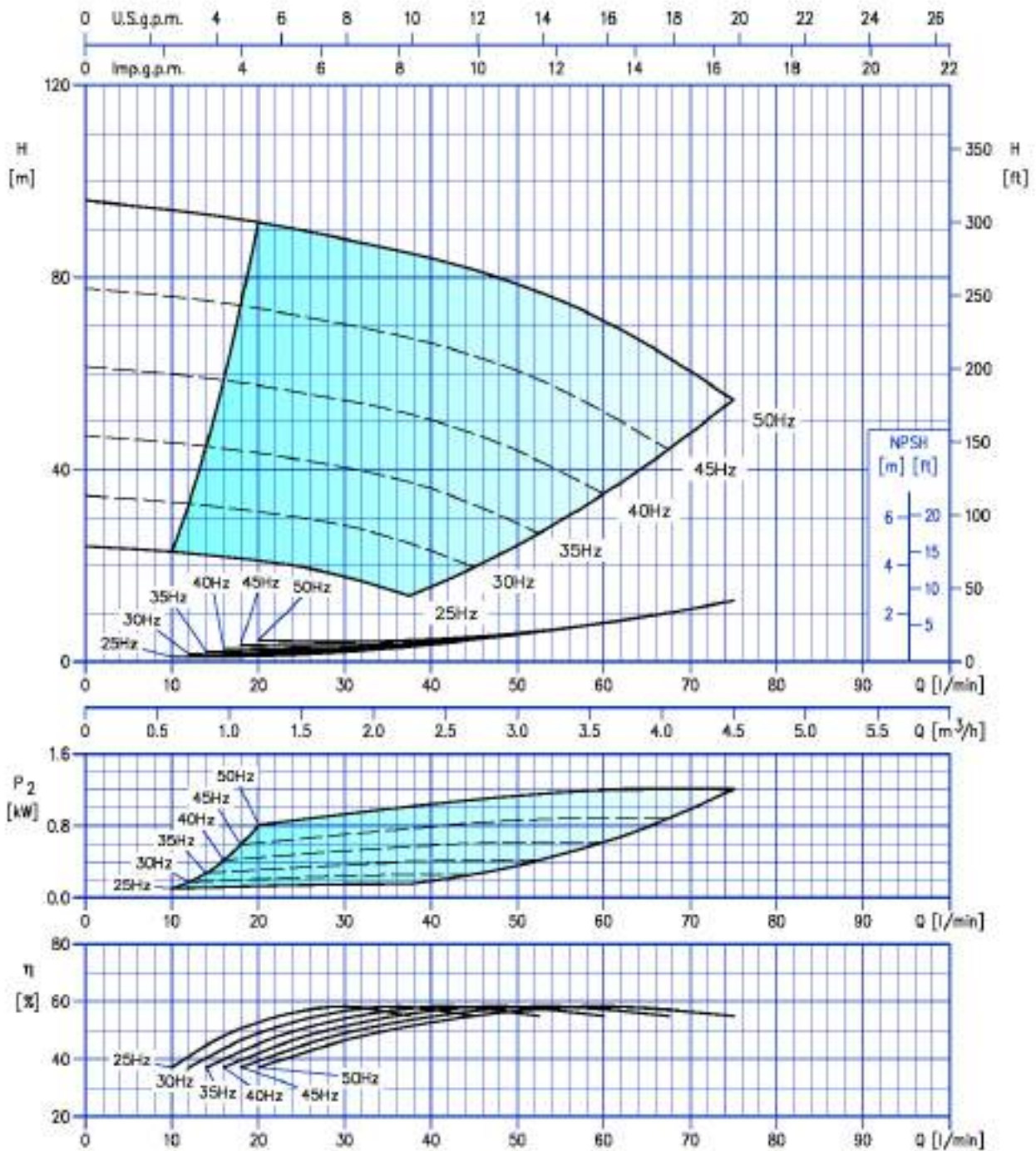

Test standard: ISO 9906: 2012 - Grade 3B

720

### EVMS(.)-K3 14/1.5

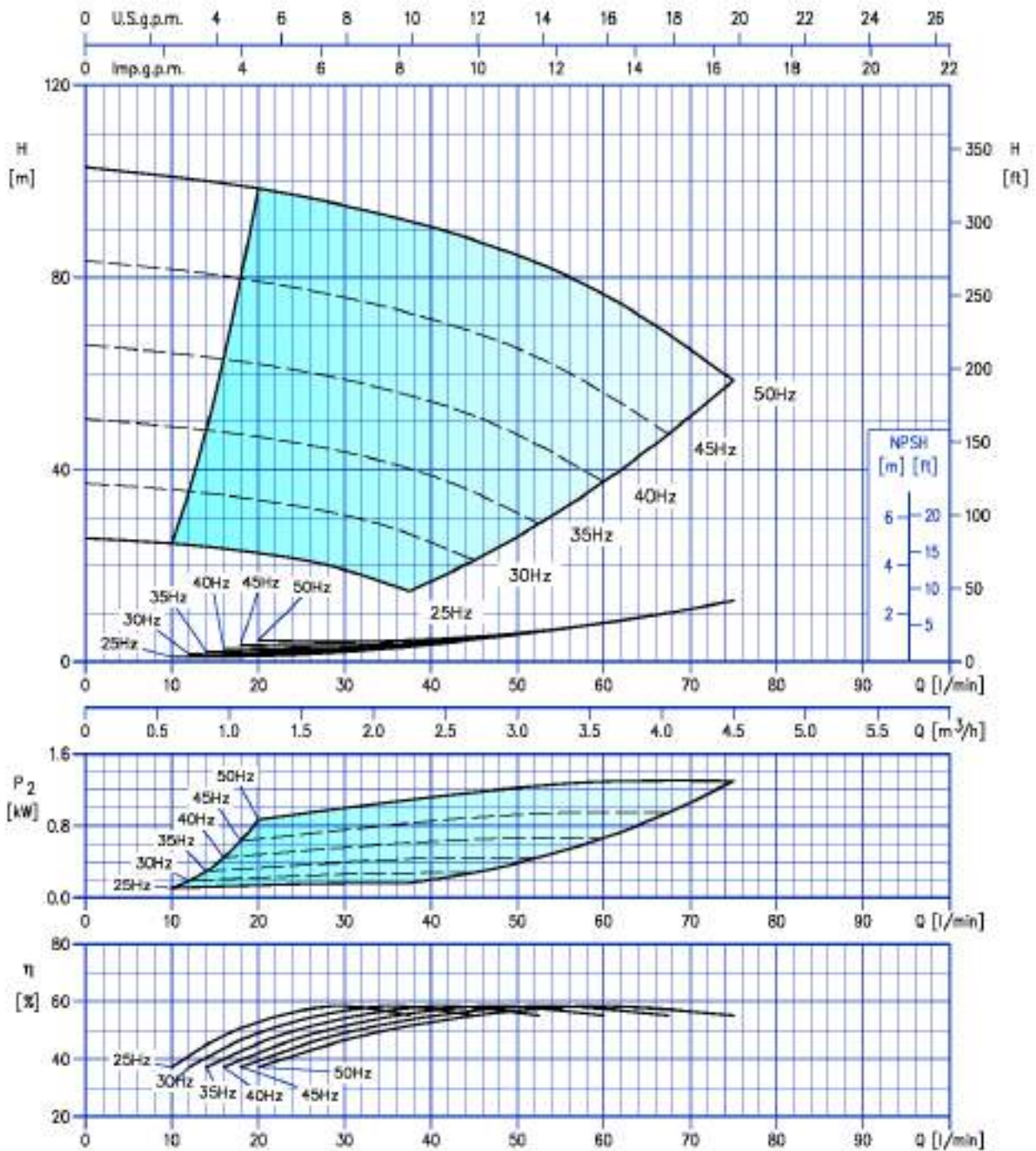

Test standard: ISO 9906: 2012 - Grade 3B

721

### EVMS(.)-K3 15/1.5

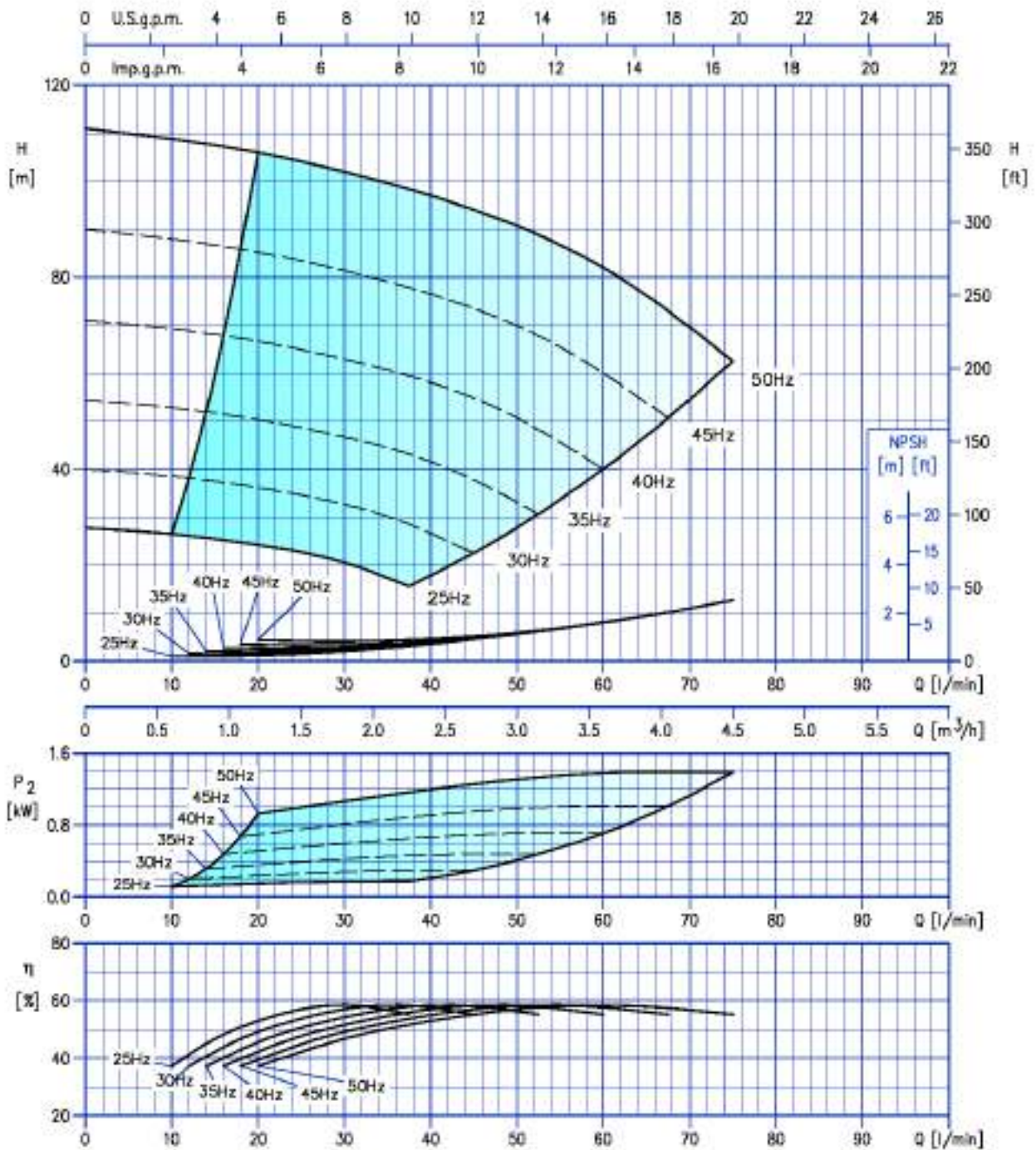

Test standard: ISO 9906: 2012 - Grade 3B



### EVMS(.)-K3 16/1.5

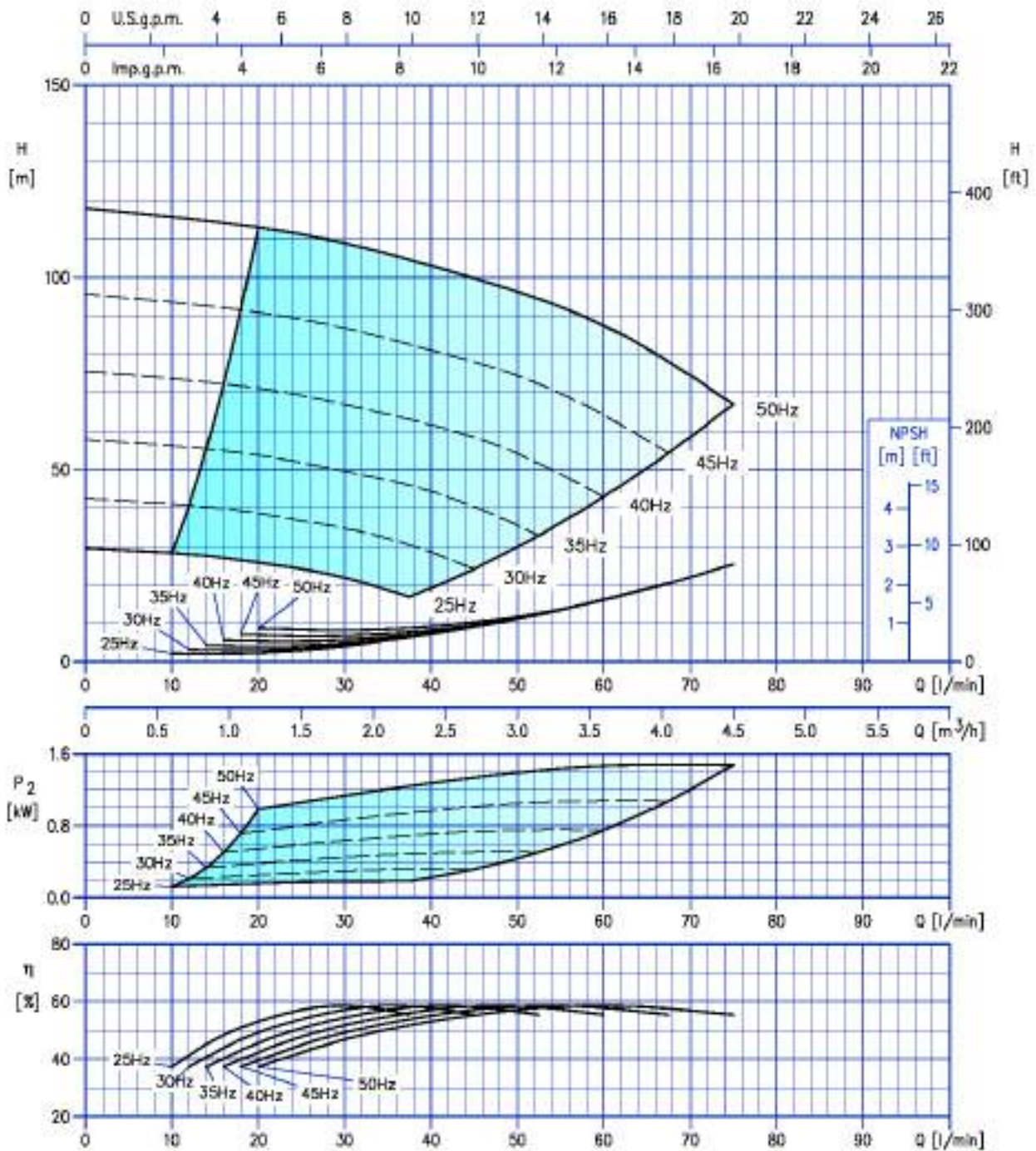

Test standard: ISO 9906: 2012 - Grade 3B

**723**

### EVMS(.)-K3 17/2.2

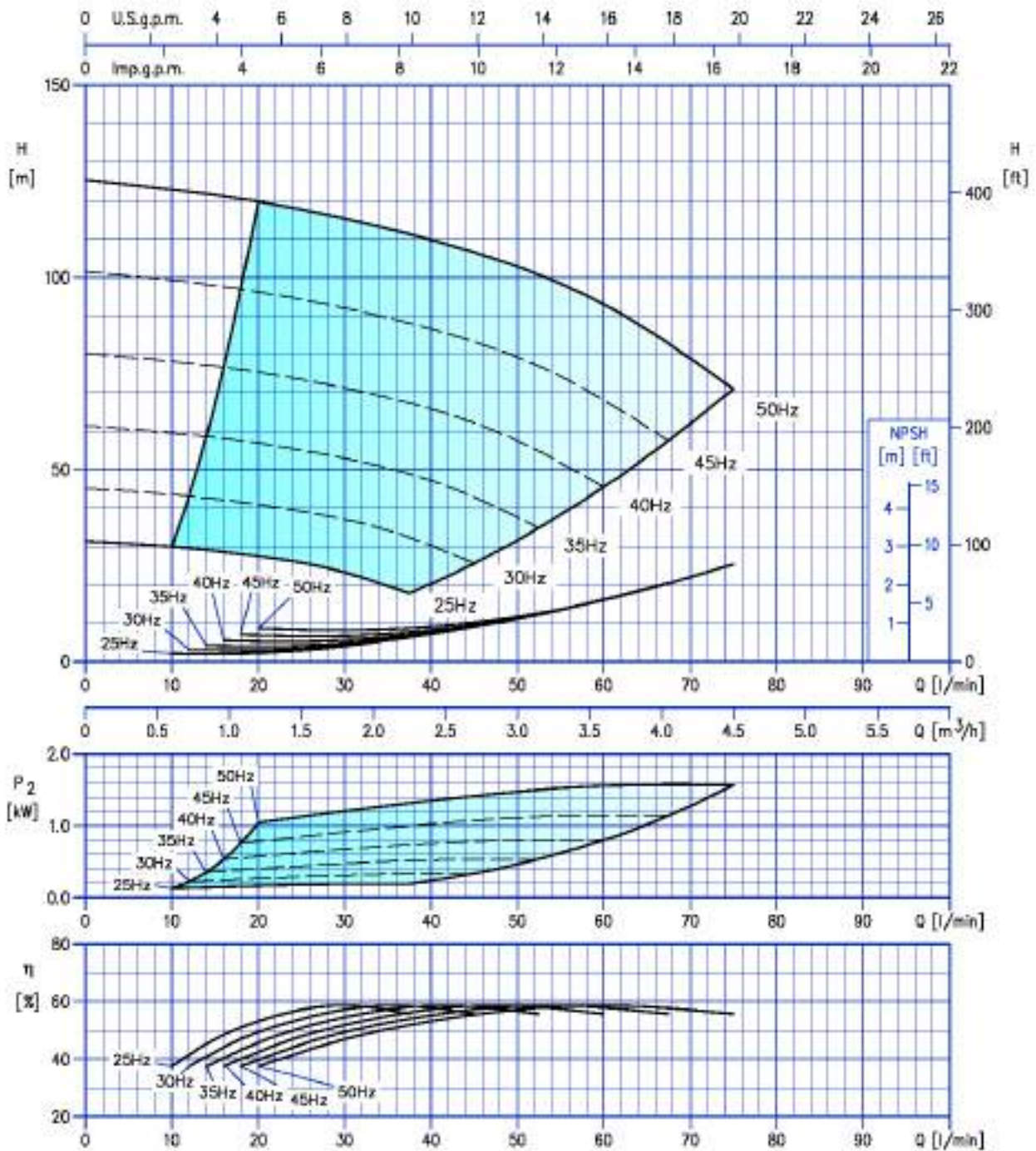

Test standard: ISO 9906: 2012 - Grade 3B

724

### EVMS(.)-K3 19/2.2

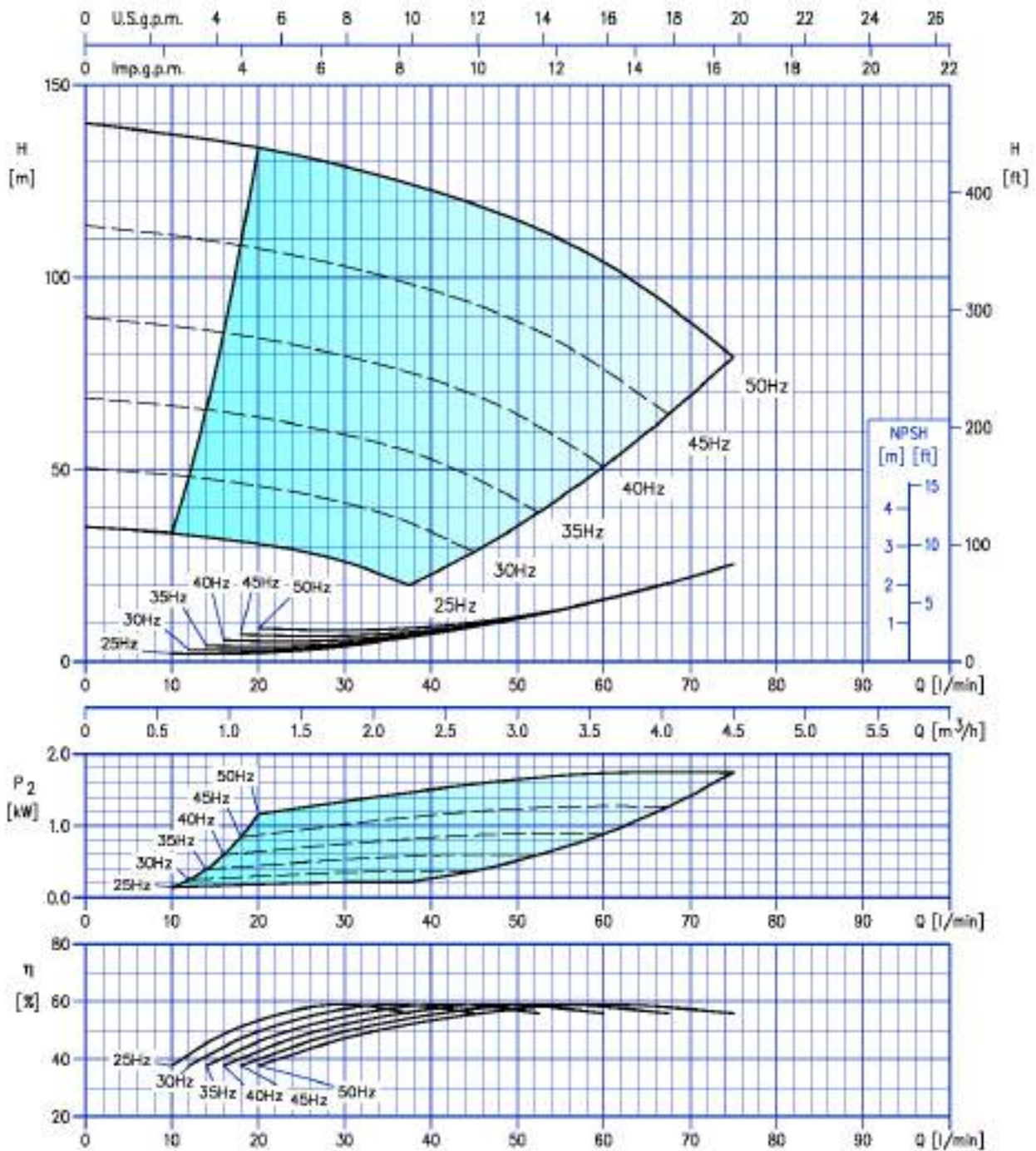

Test standard: ISO 9906: 2012 - Grade 3B

**725**

### EVMS(.)-K3 21/2.2

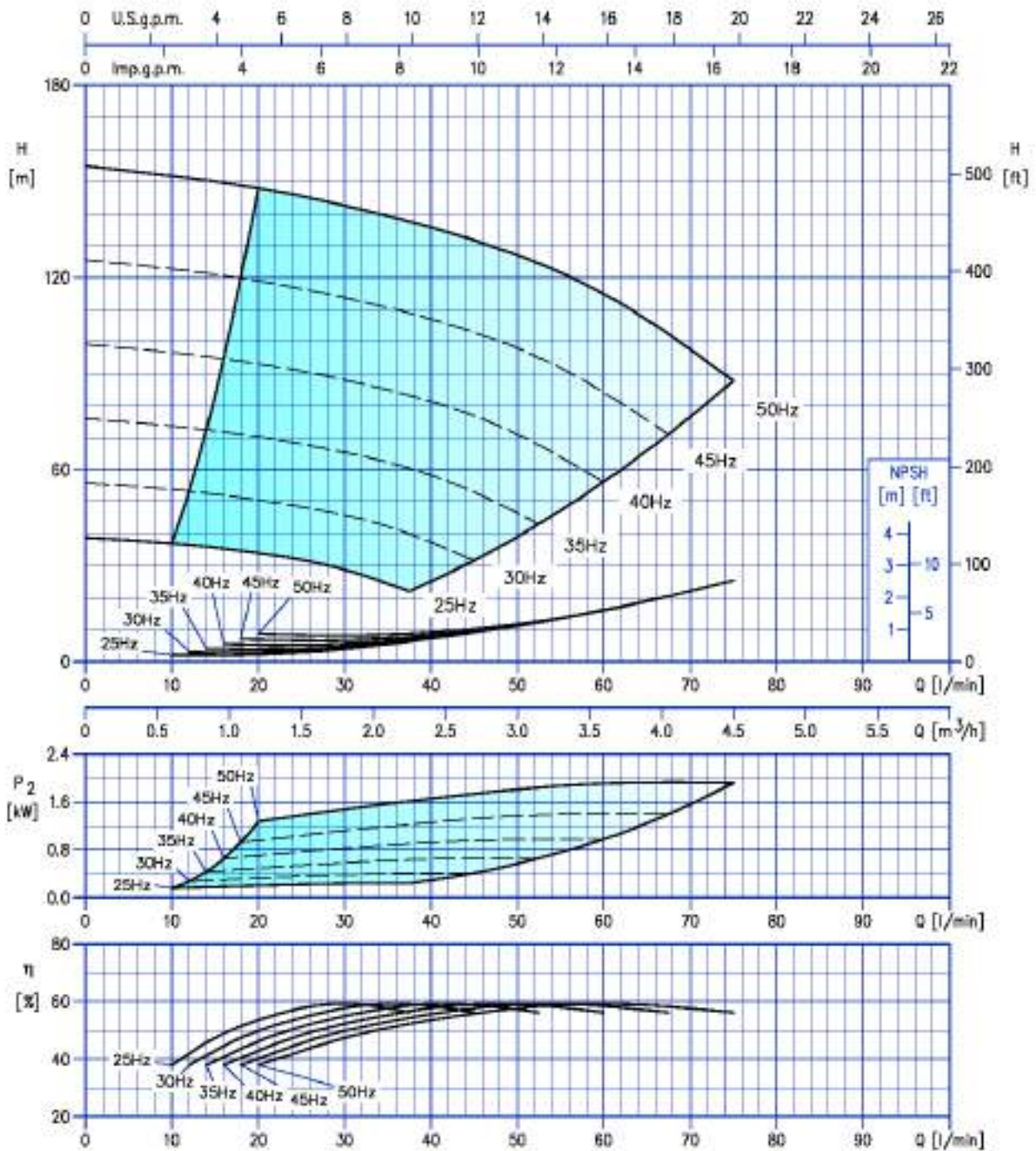

Test standard: ISO 9906: 2012 - Grade 3B

726

### EVMS(.)-K3 23/2.2

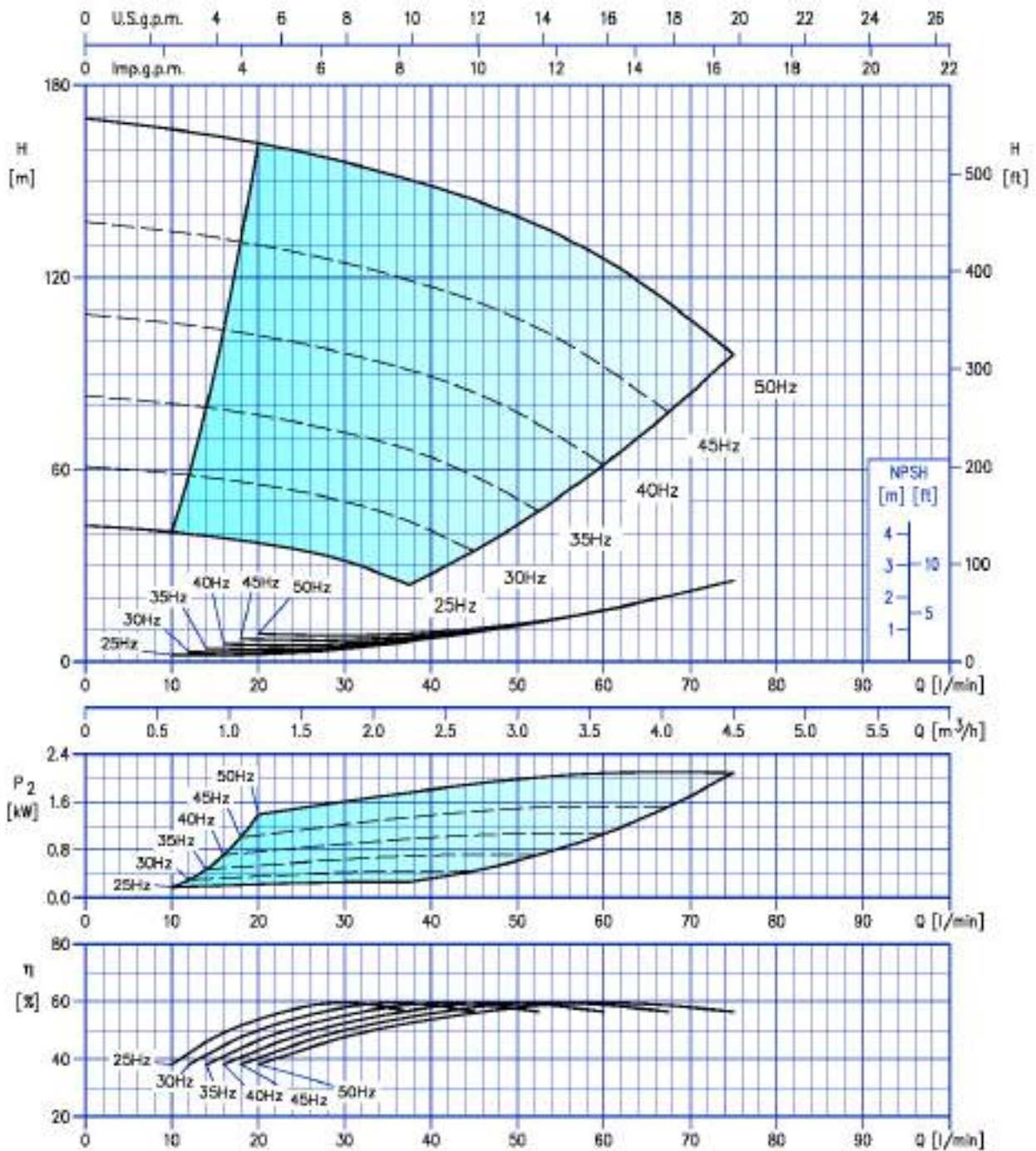

Test standard: ISO 9906: 2012 - Grade 3B

**727**

### EVMS(.)-K3 24/2.2

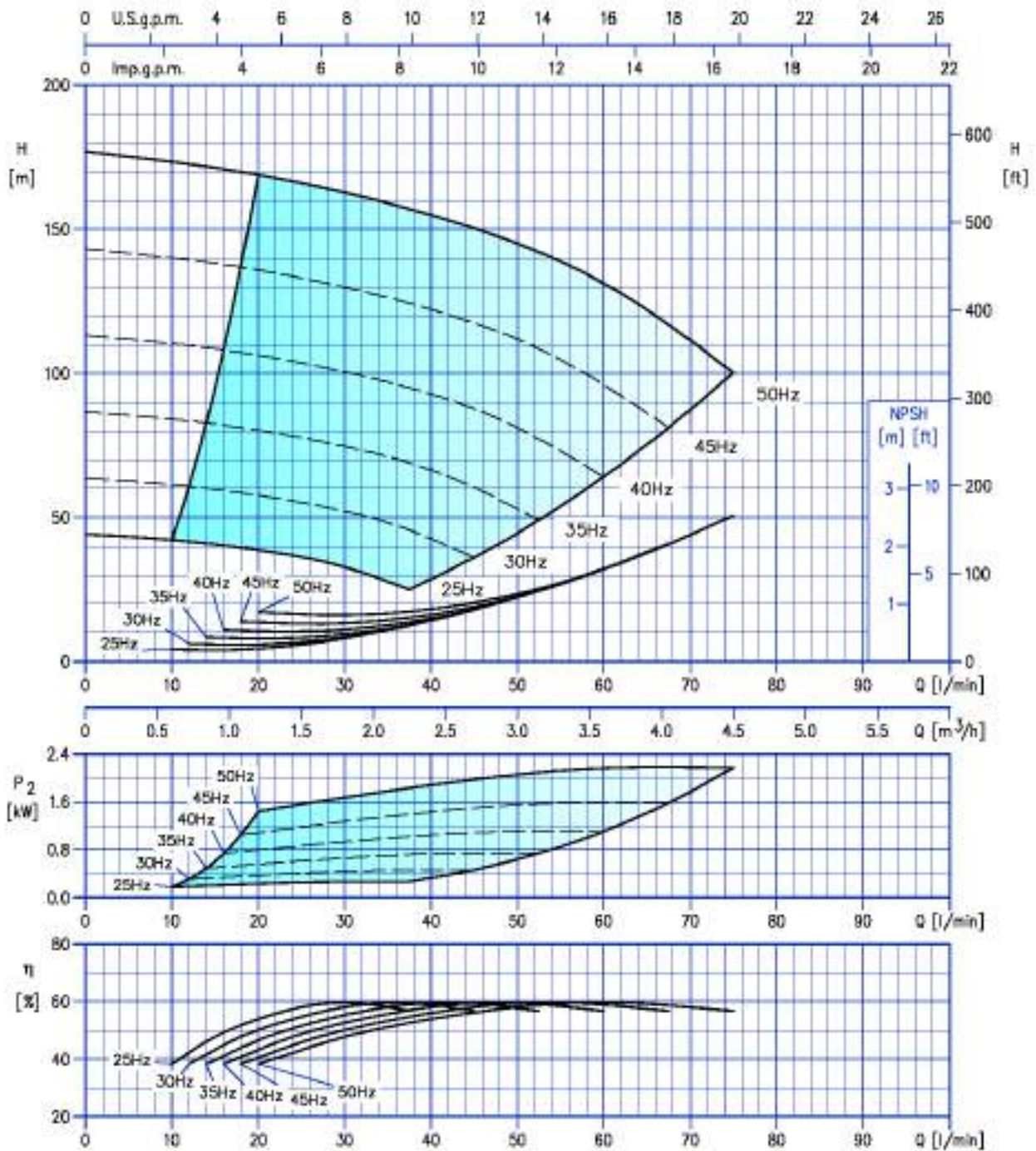

Test standard: ISO 9906: 2012 - Grade 3B

**728**

### EVMS(.)-K3 25/3.0

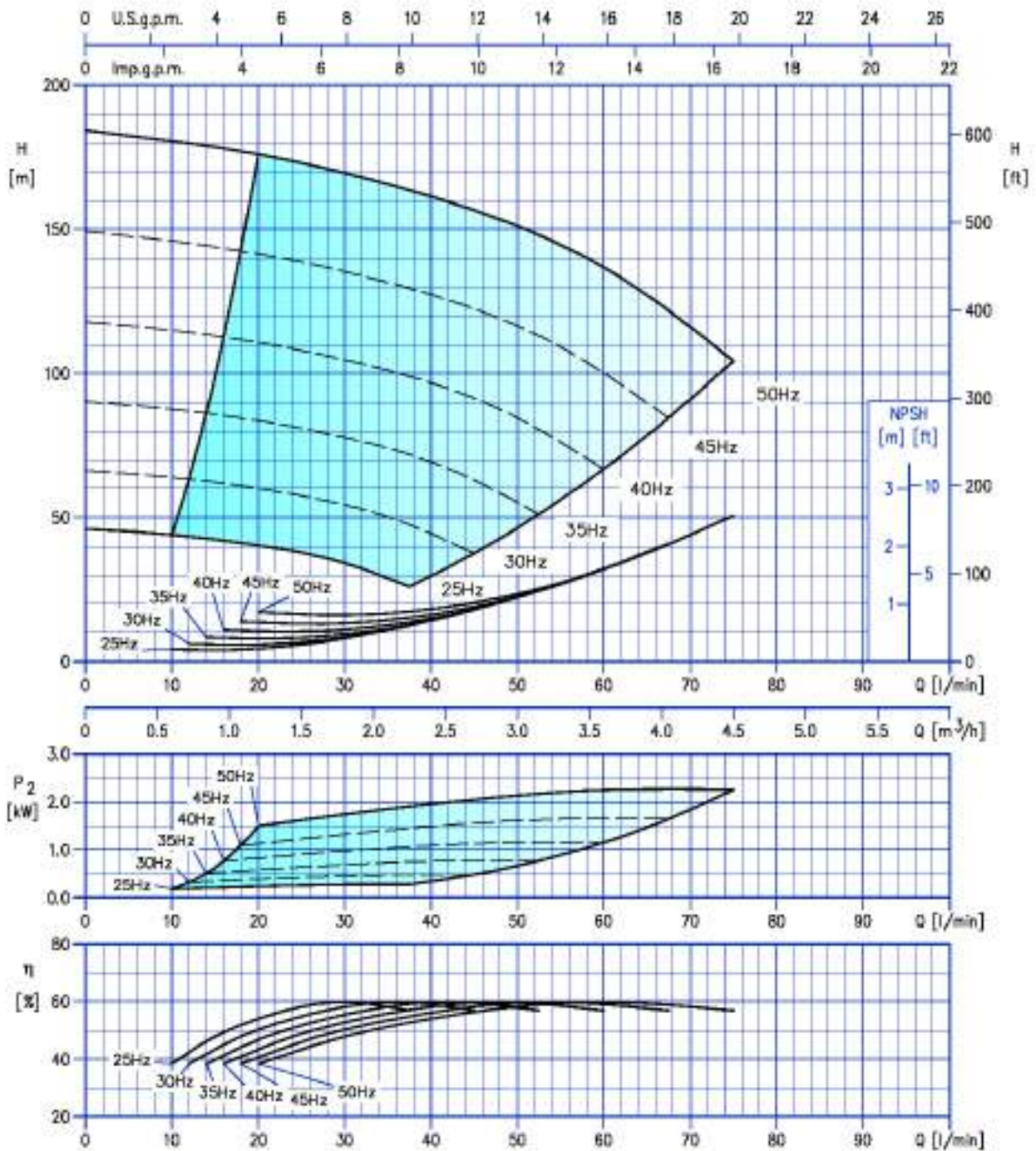

Test standard: ISO 9906: 2012 - Grade 3B

729

### EVMS(.)-K3 27/3.0

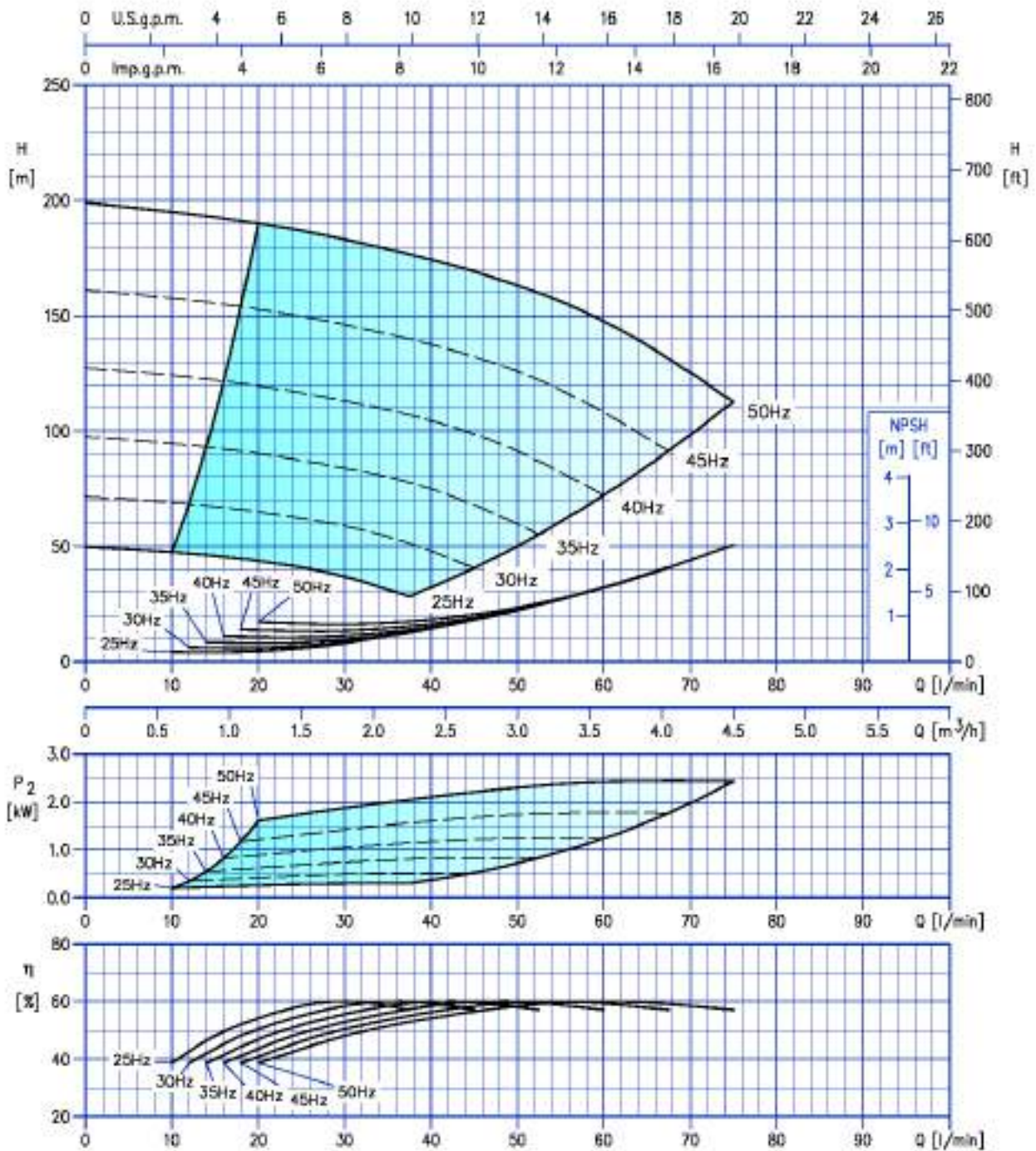

Test standard: ISO 9906: 2012 - Grade 3B

**730**



### EVMS(.)-K3 29/3.0

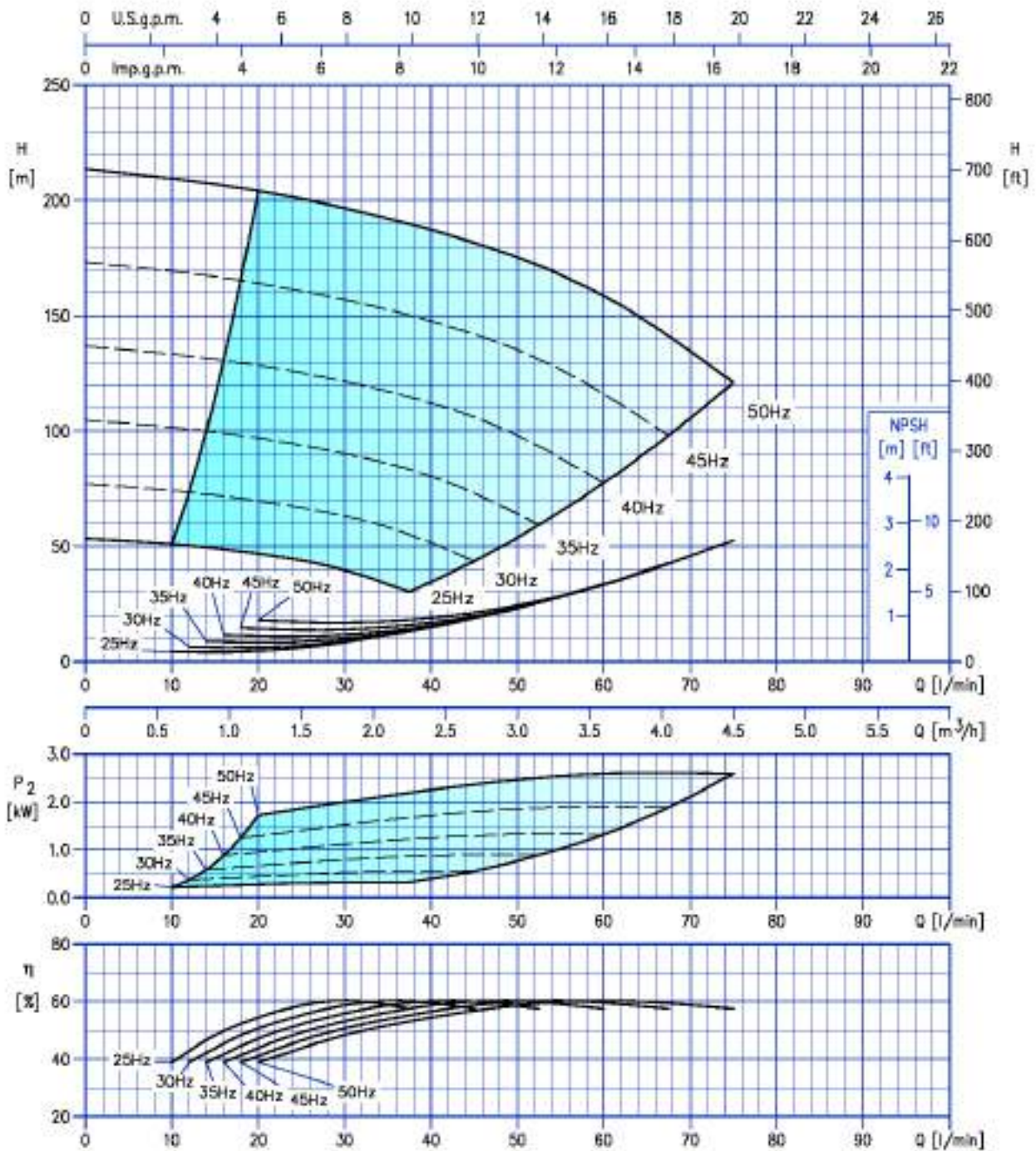

Test standard: ISO 9906: 2012 - Grade 3B

731

### EVMS(.)-K3 31/3.0

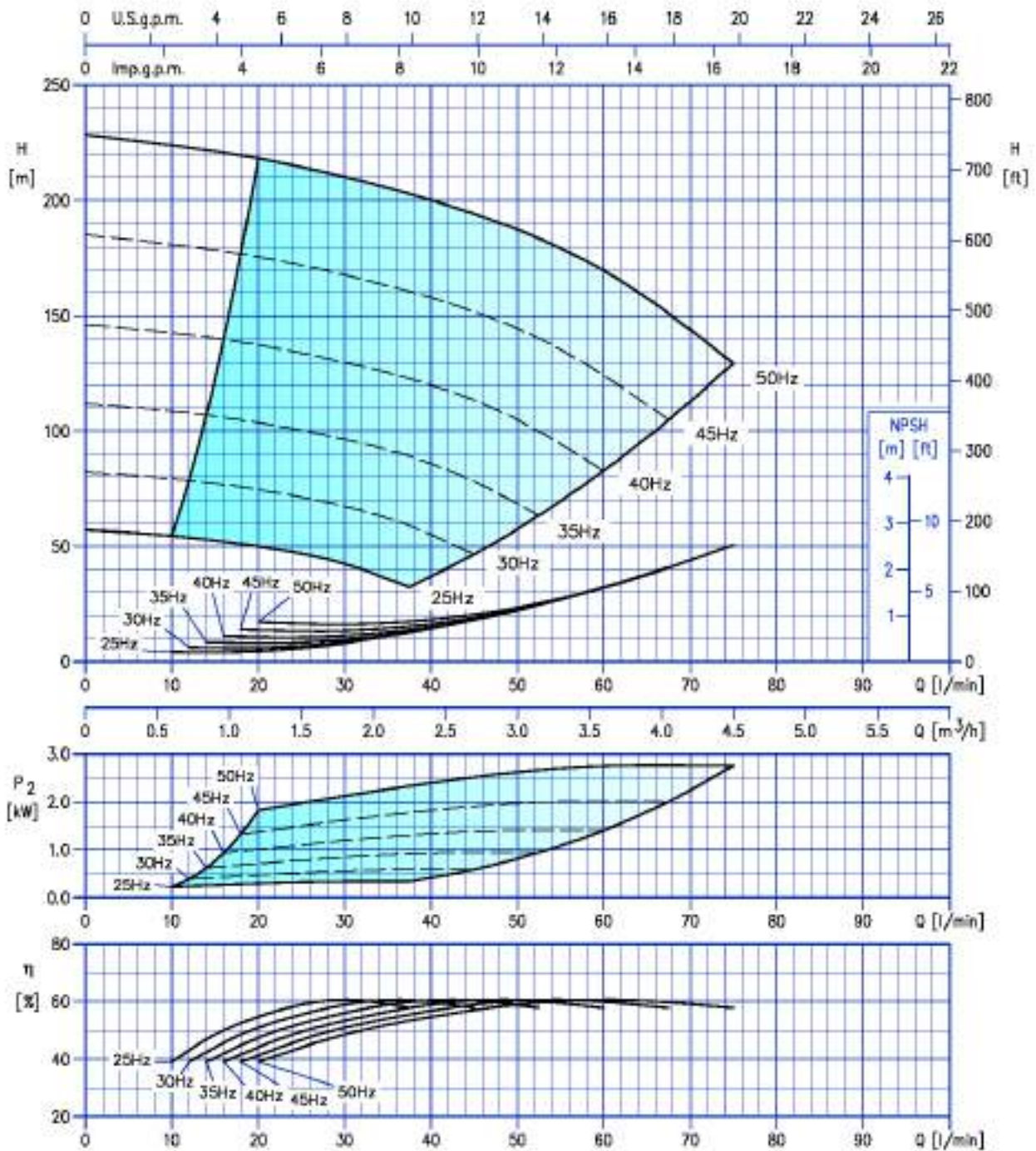

Test standard: ISO 9906: 2012 - Grade 3B

732

### EVMS(.)-K3 33/3.0

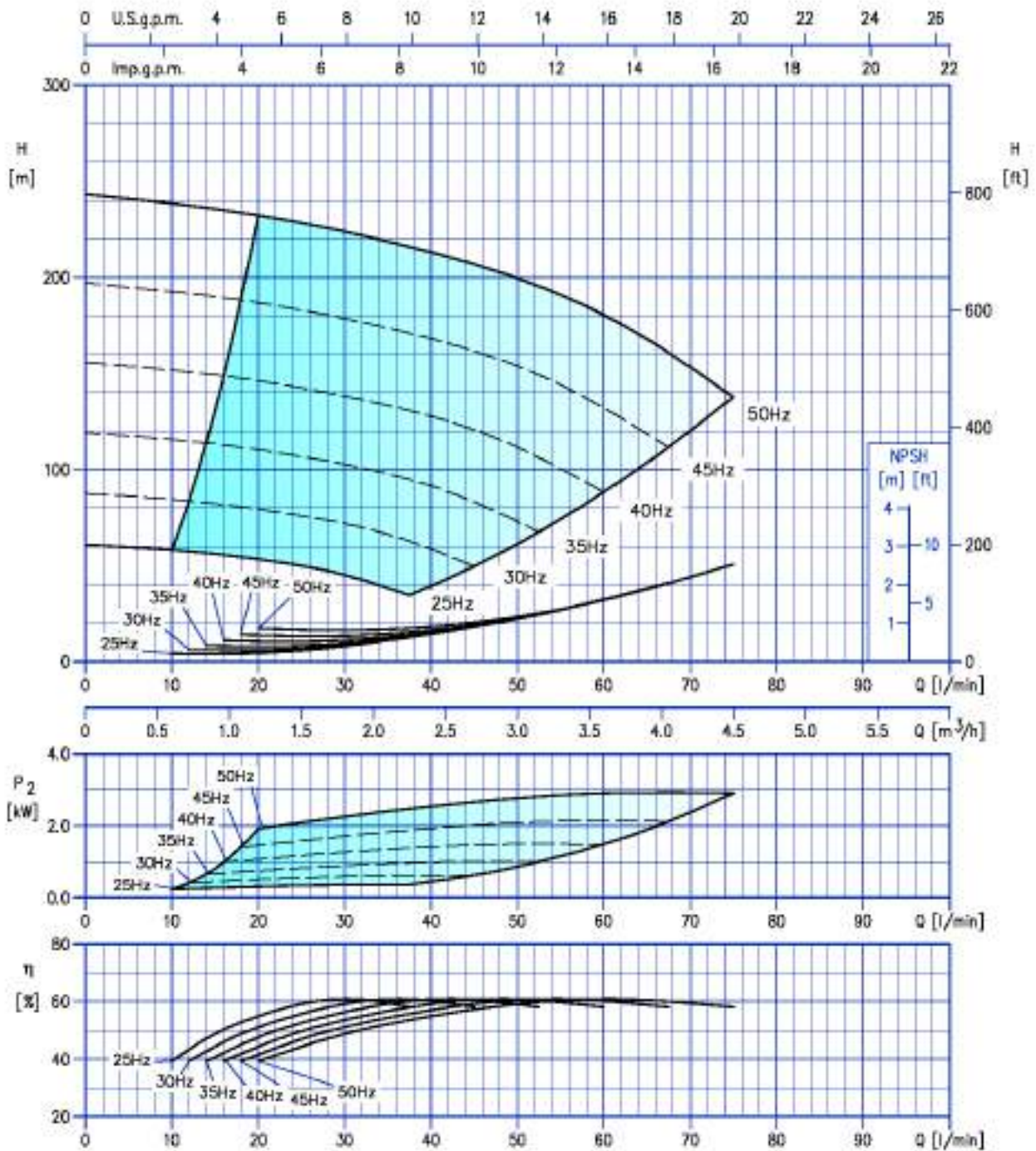

Test standard: ISO 9906: 2012 - Grade 3B

733

### EVMS(.)-K5 4/0.75

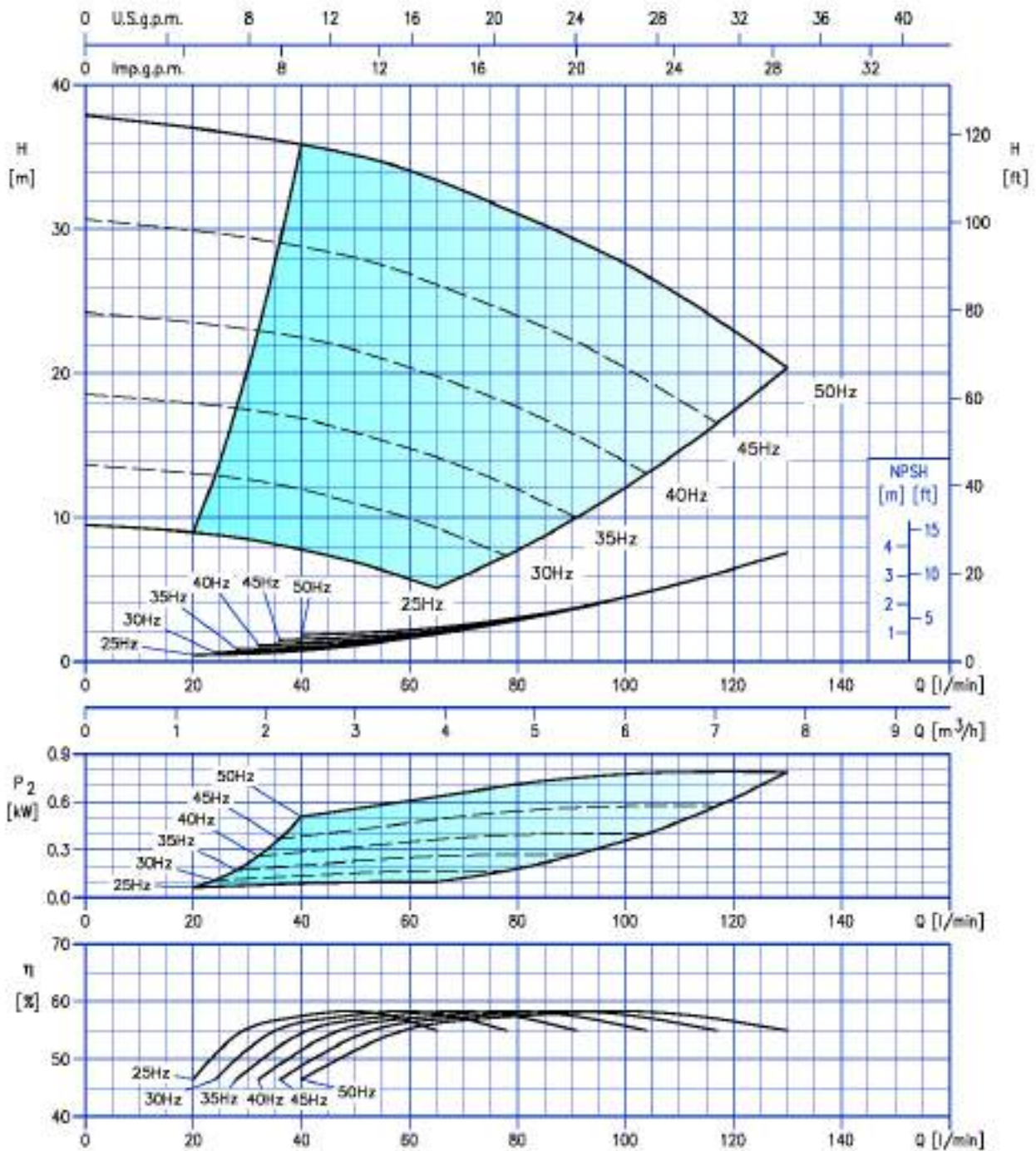

Test standard: ISO 9906: 2012 - Grade 3B

734

### EVMS(-)K5 5/1.1

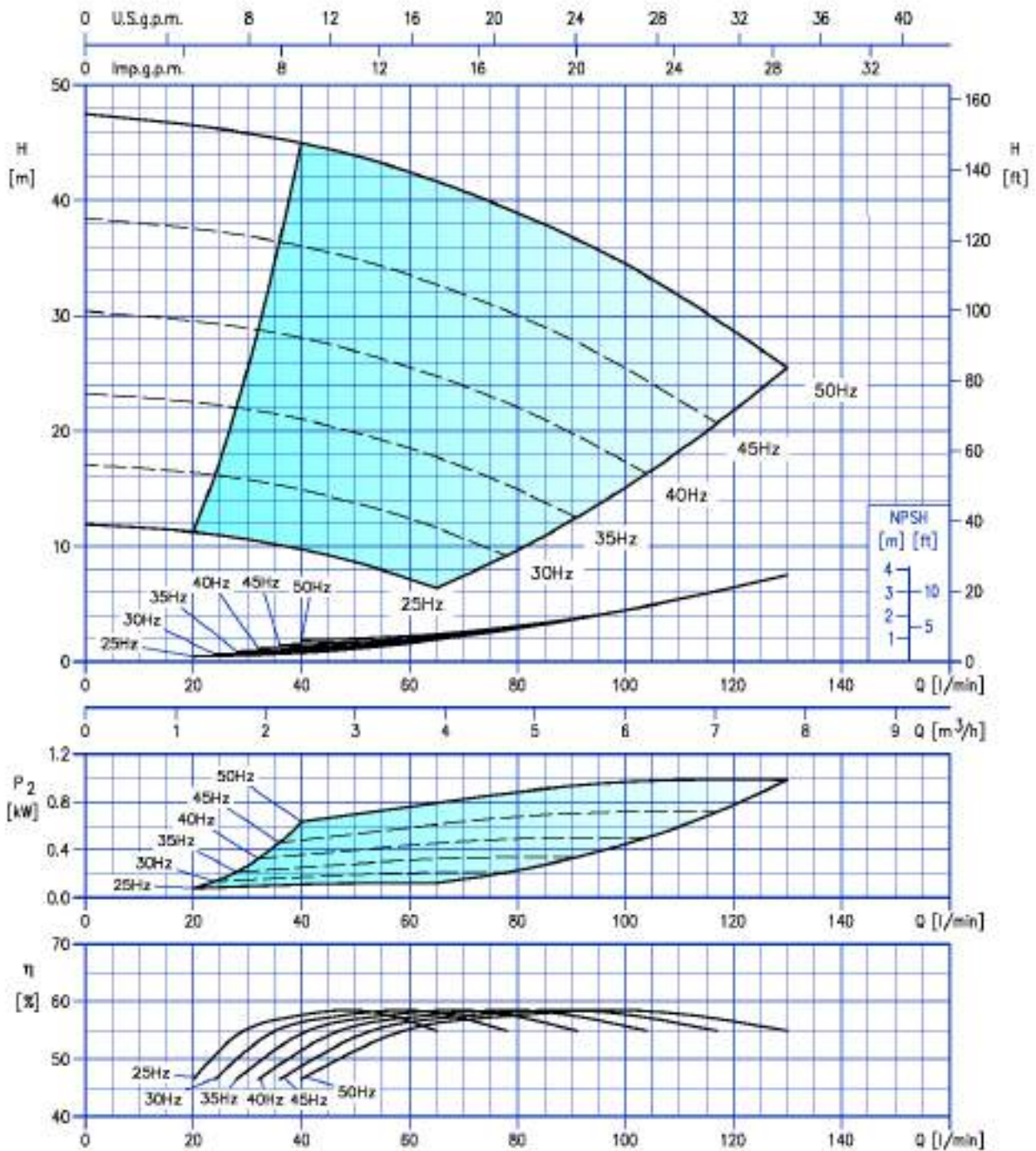

Test standard: ISO 9906: 2012 - Grade 3B

735

### EVMS(.)-K5 6/1.5

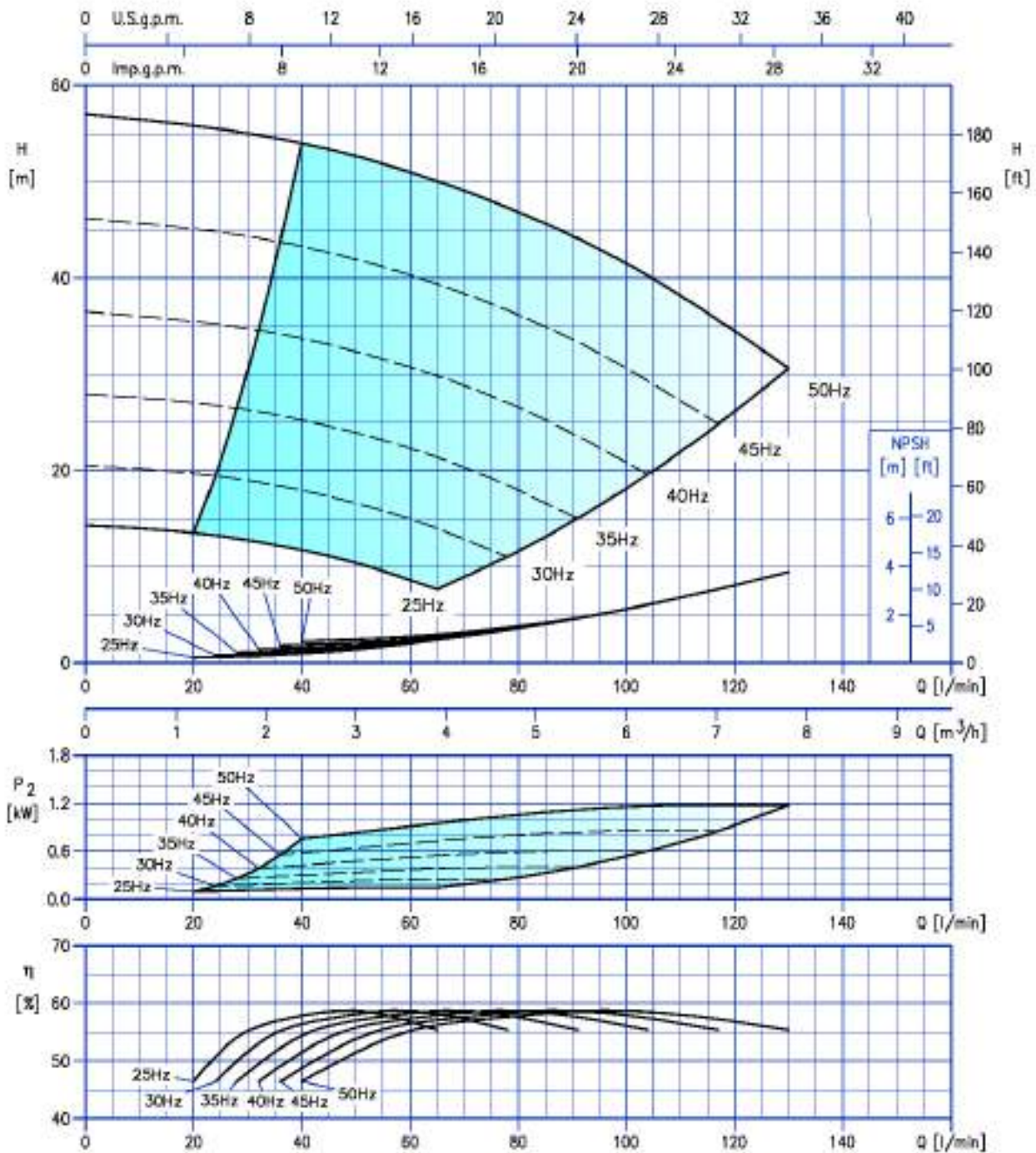

Test standard: ISO 9906: 2012 - Grade 3B

736

### EVMS(.)-K5 7/1.5

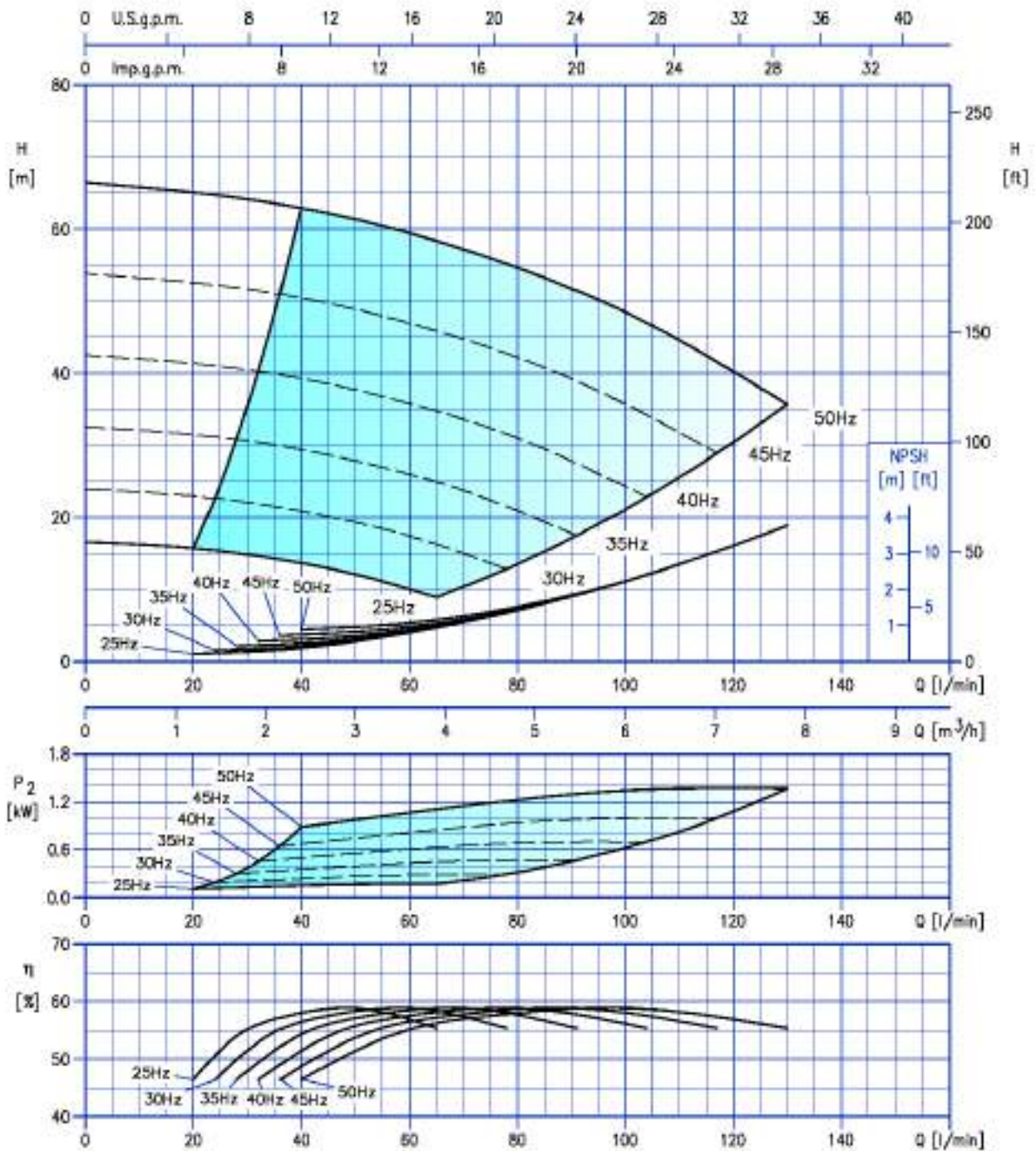

Test standard: ISO 9906: 2012 - Grade 3B

737

### EVMS(.)-K5 8/2.2

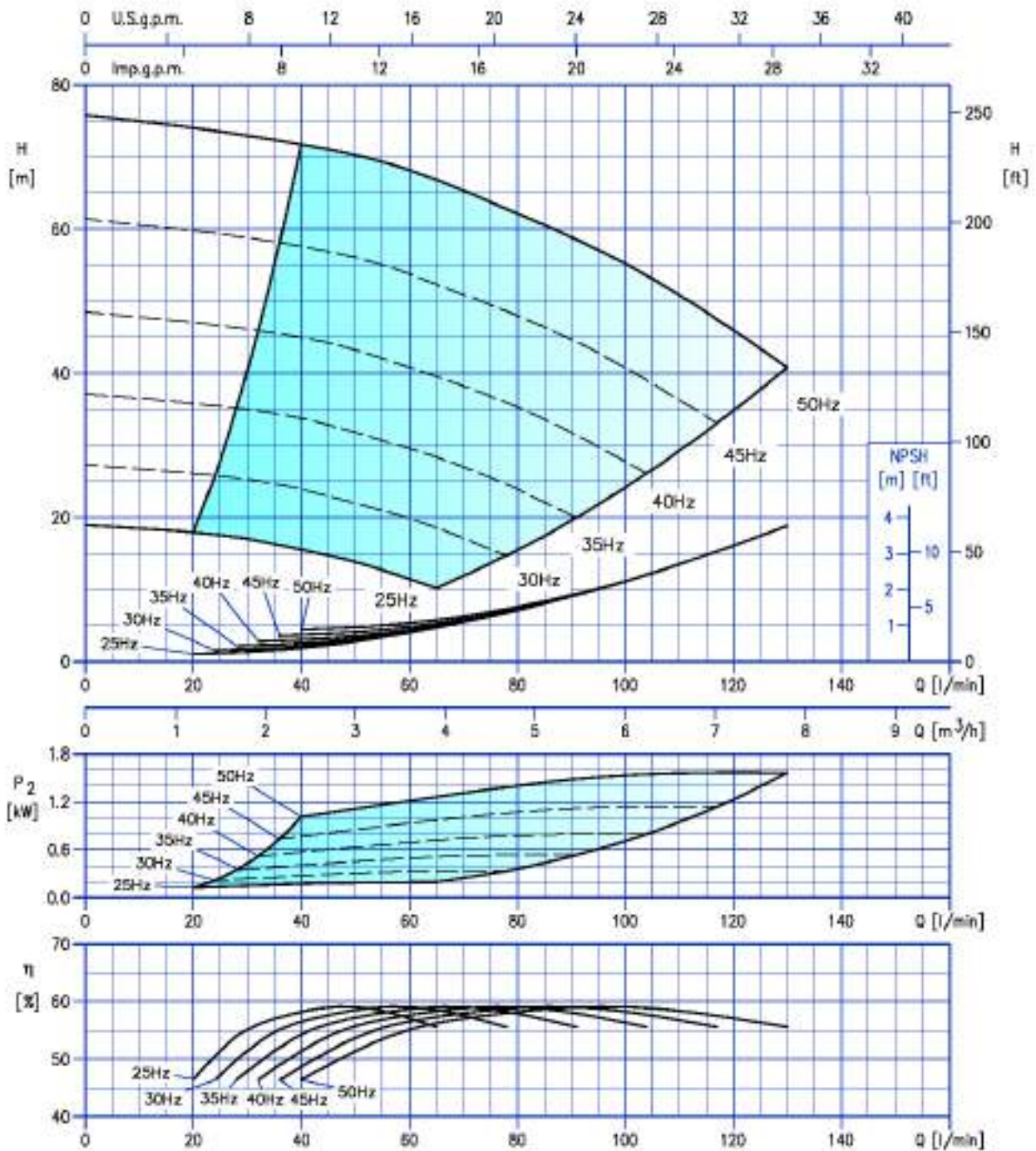

Test standard: ISO 9906: 2012 - Grade 3B

738



### EVMS(.)-K5 9/2.2

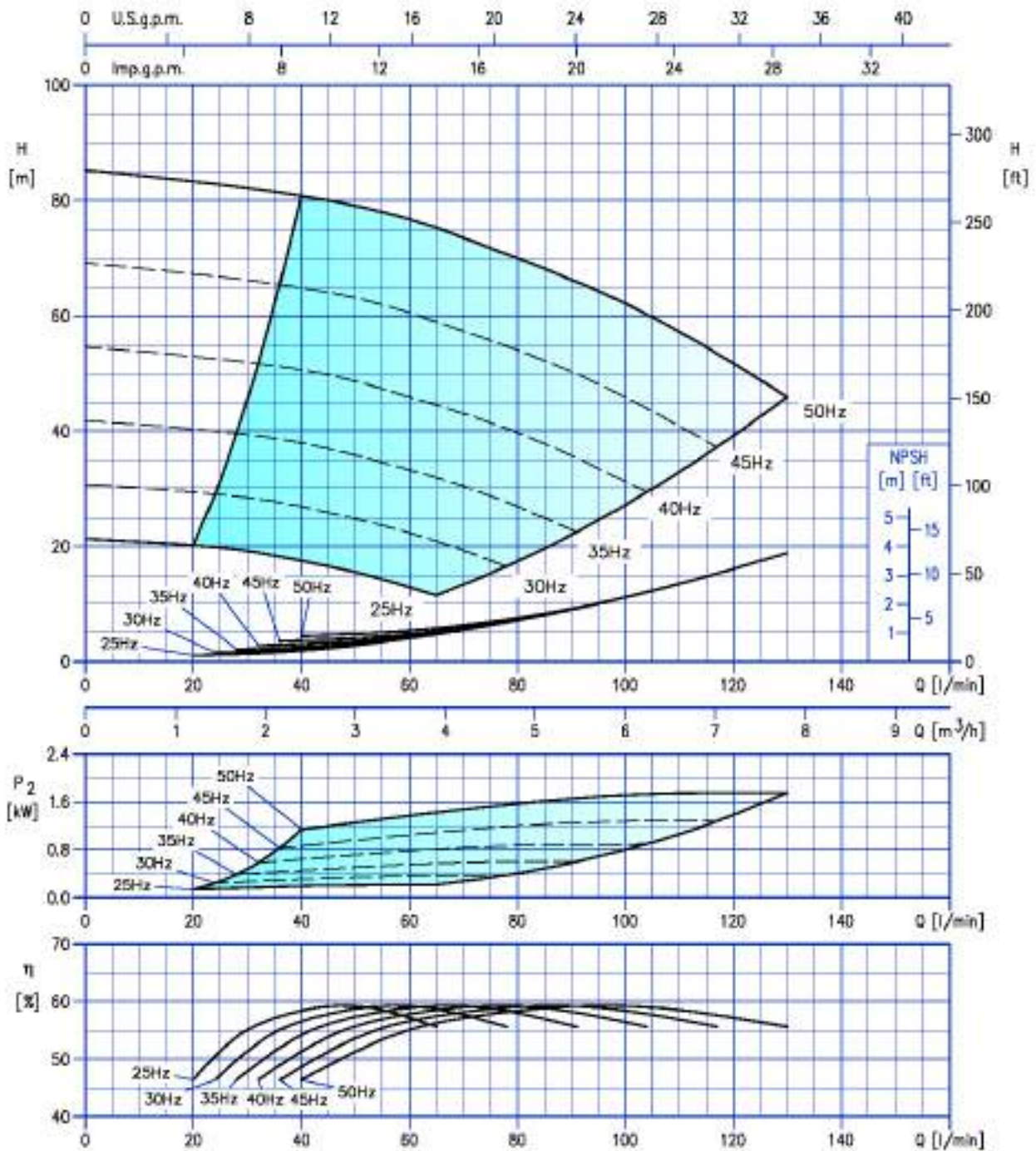

Test standard: ISO 9906: 2012 - Grade 3B

739

### EVMS(.)-K5 10/2.2

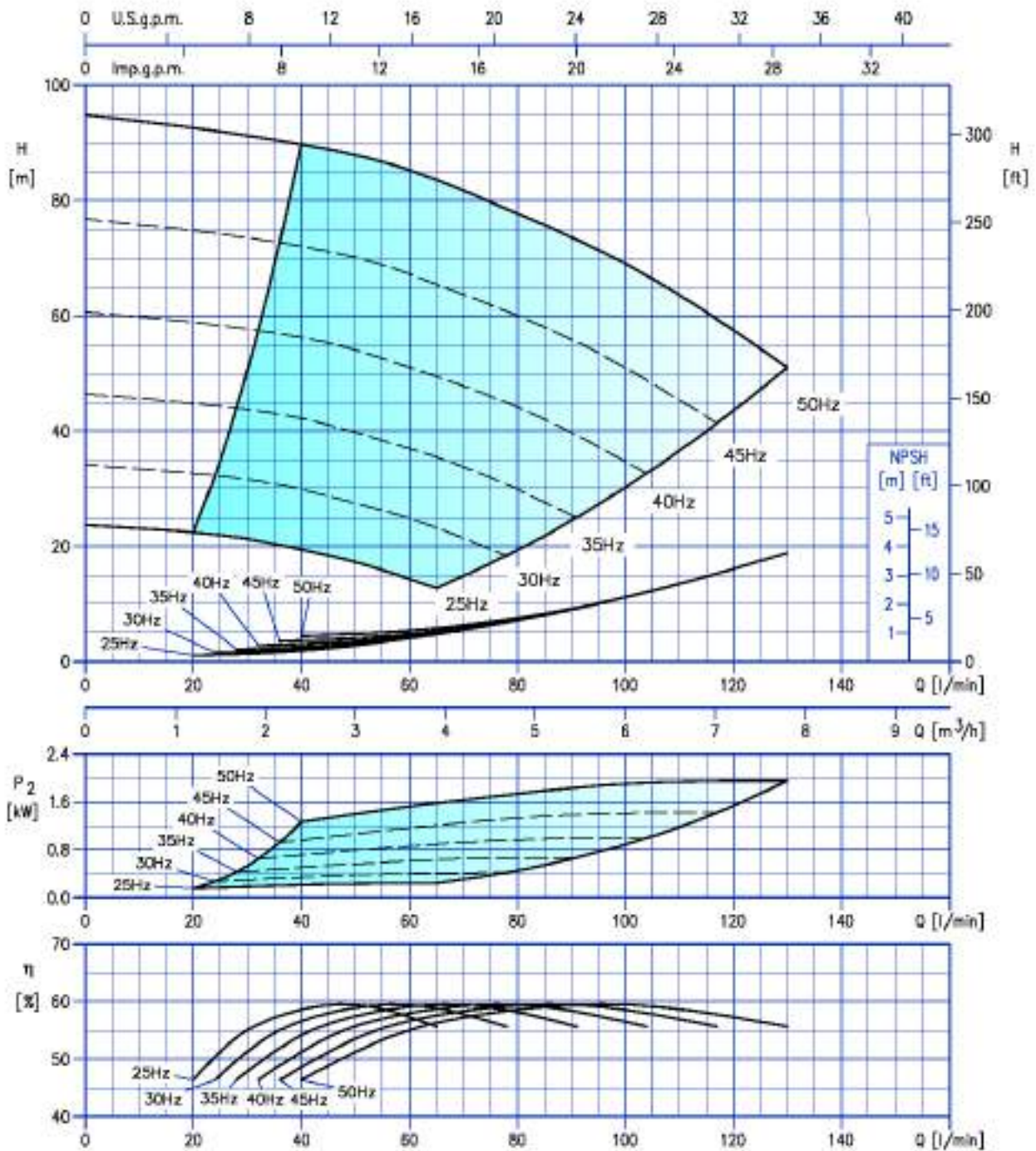

Test standard: ISO 9906: 2012 - Grade 3B

740

### EVMS(.)-K5 11/2.2

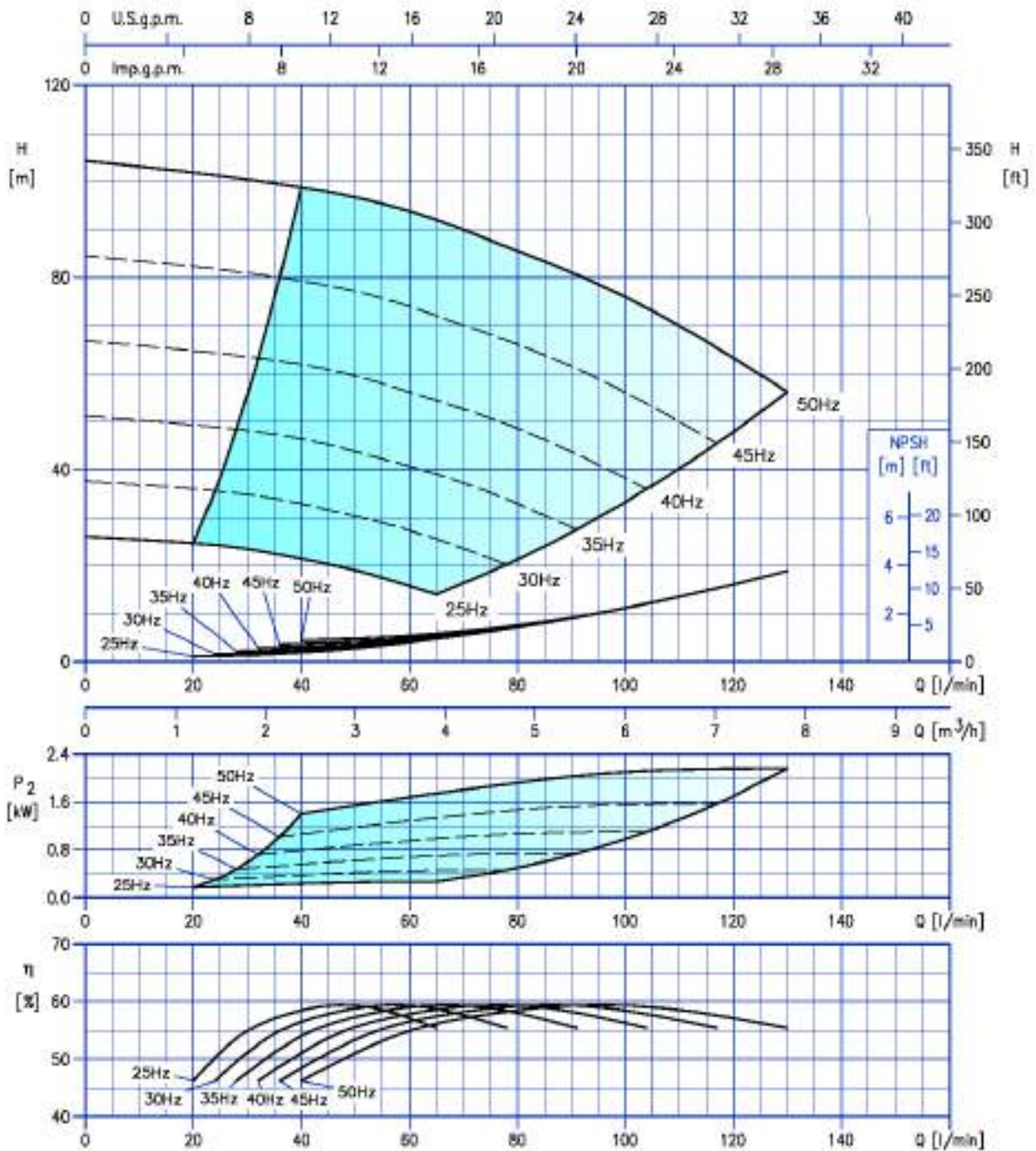

Test standard: ISO 9906: 2012 - Grade 3B

### EVMS(.)-K5 12/3.0

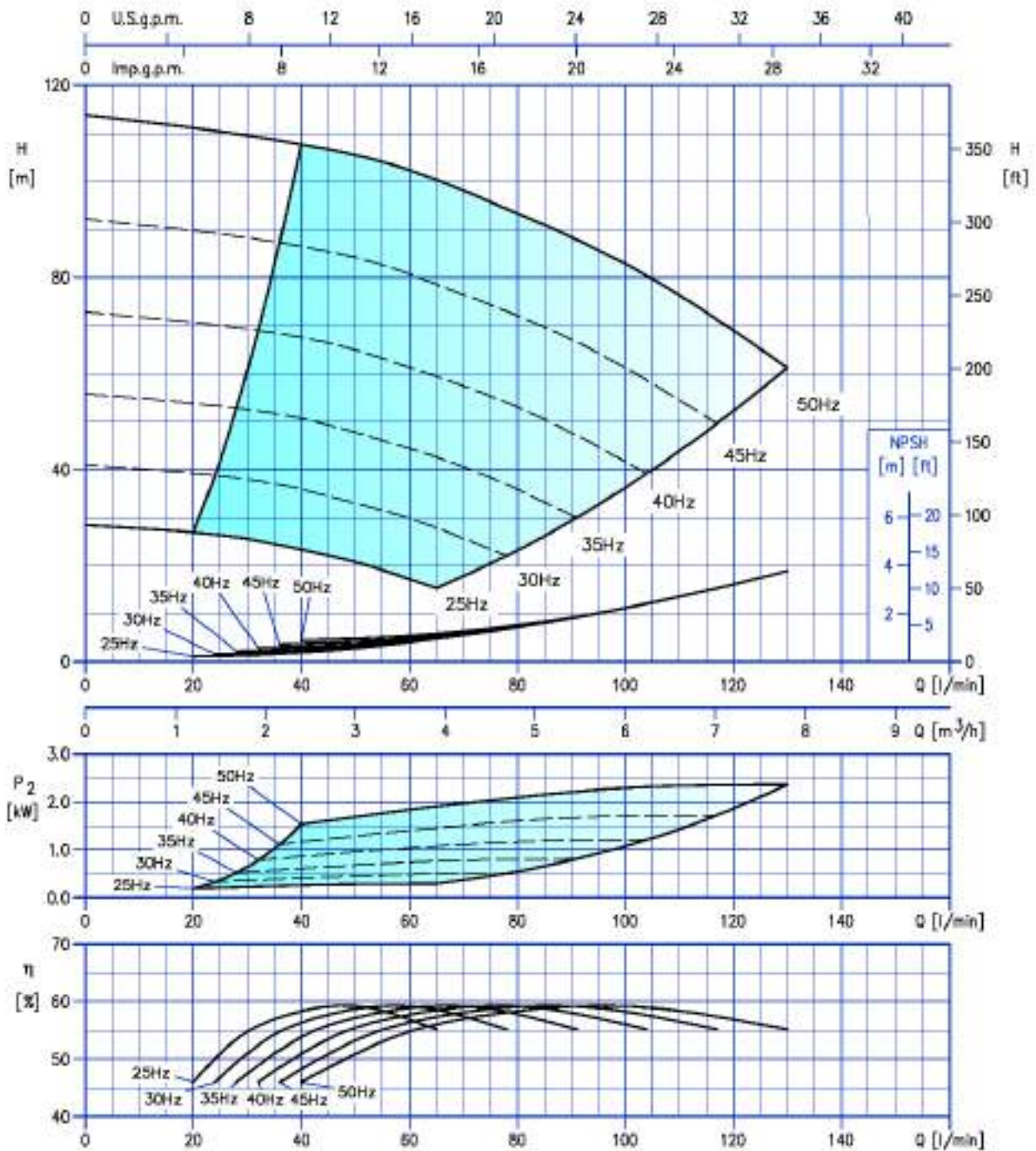

Test standard: ISO 9906: 2012 - Grade 3B

742

### EVMS(.)-K5 13/3.0

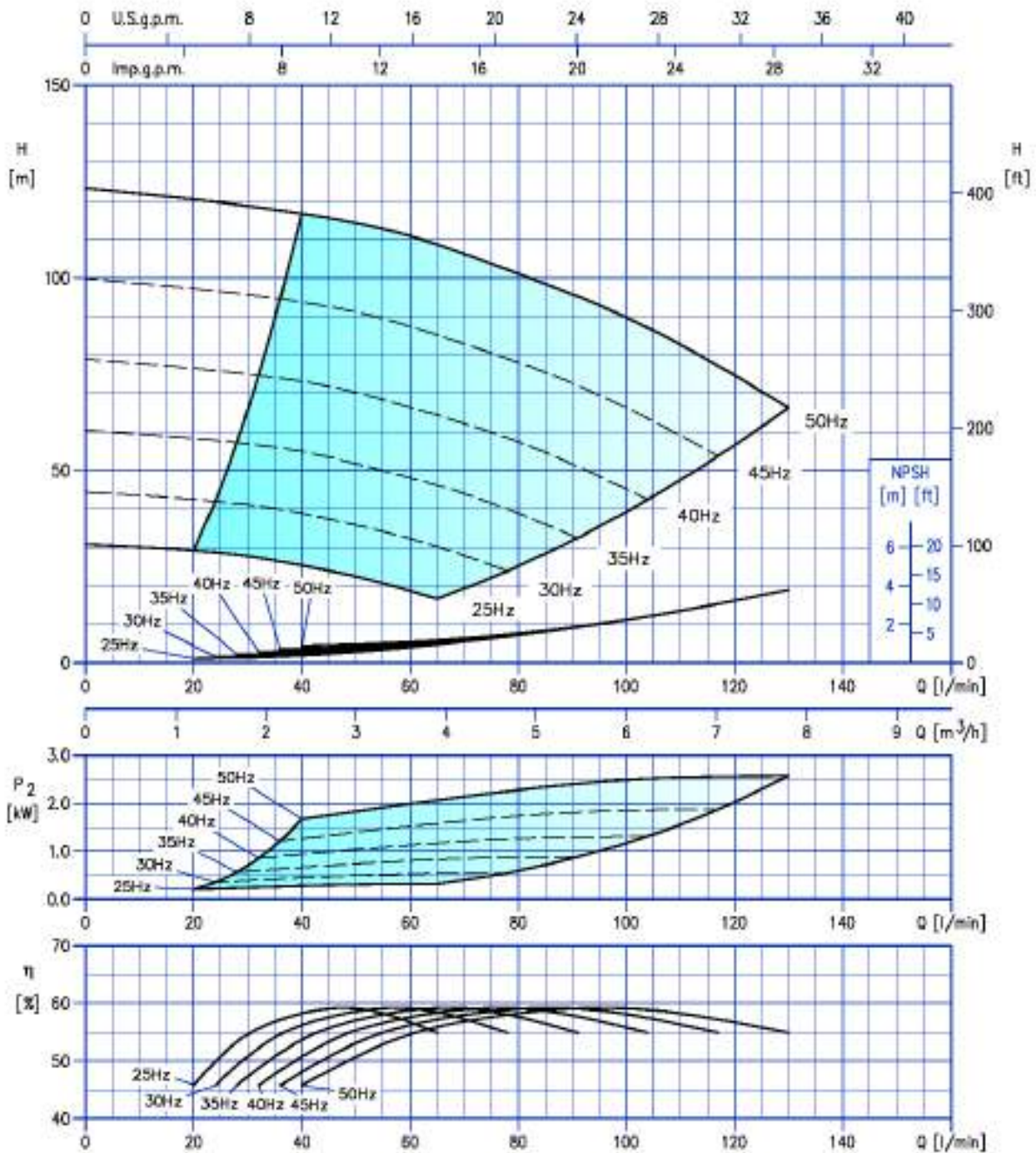

Test standard: ISO 9906: 2012 - Grade 3B

743

### EVMS(.)-K5 14/3.0

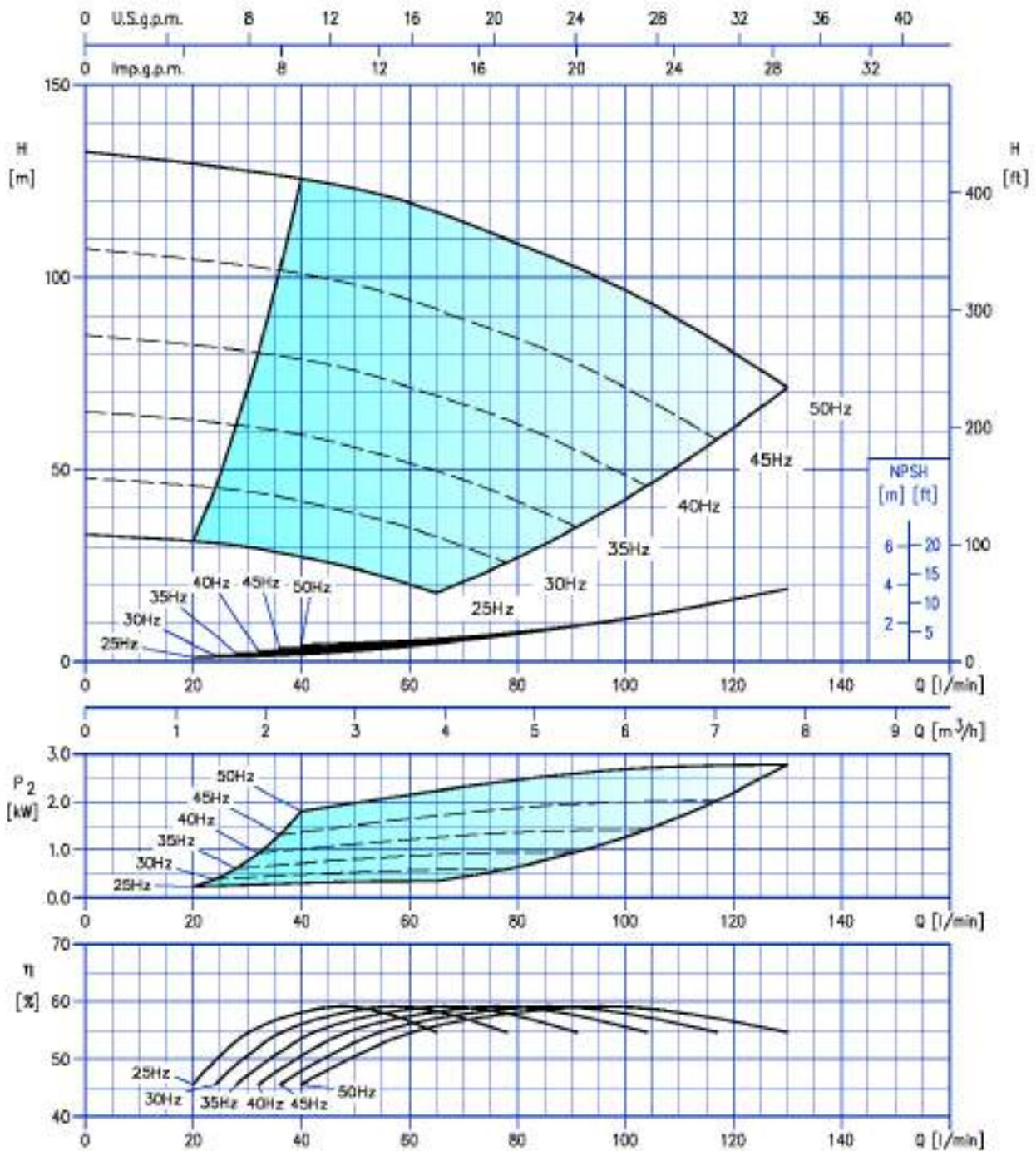

Test standard: ISO 9906: 2012 - Grade 3B

744

### EVMS(.)-K5 15/3.0

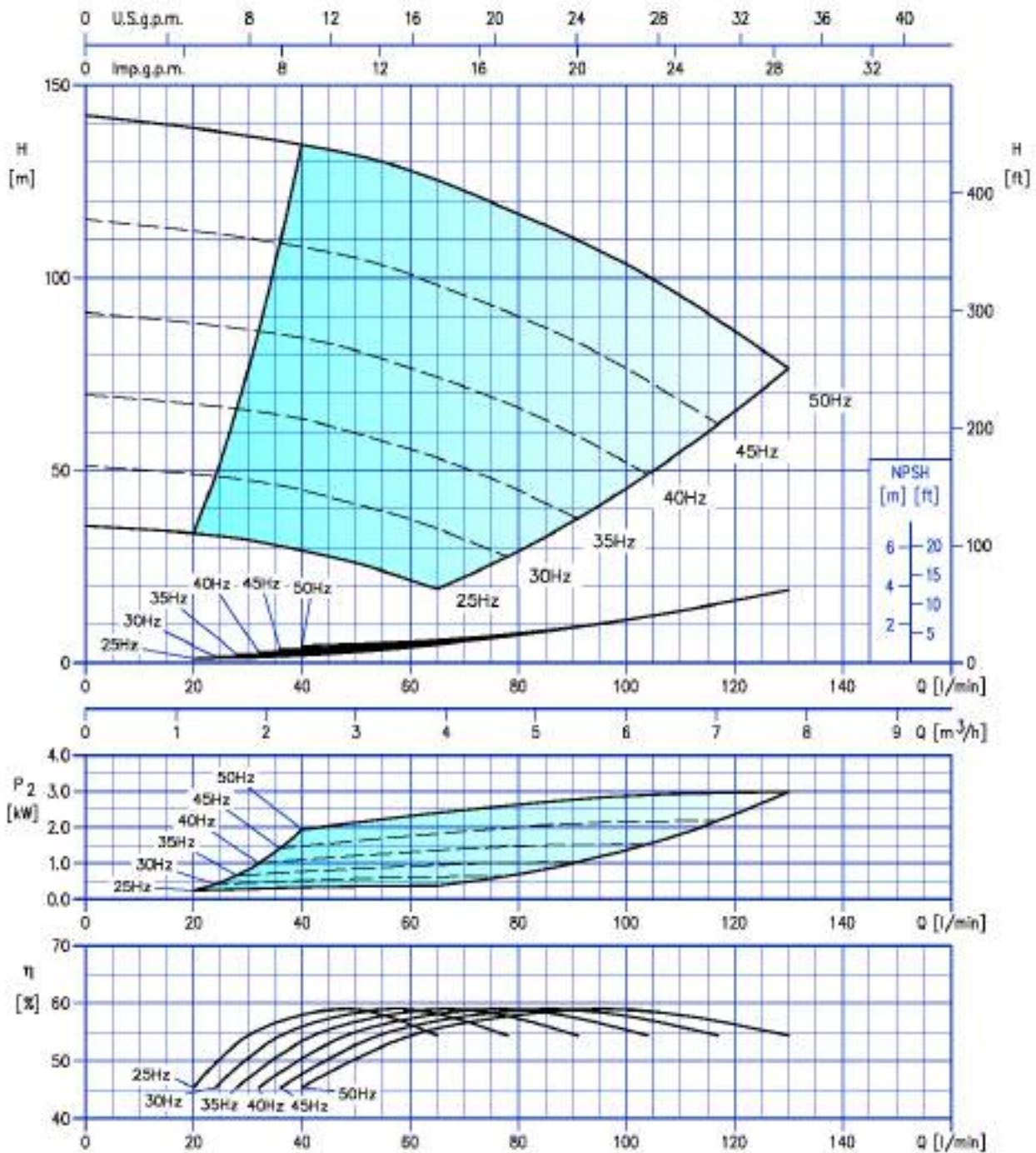

Test standard: ISO 9906: 2012 - Grade 3B

745

### EVMS(.)-K5 17/4.0

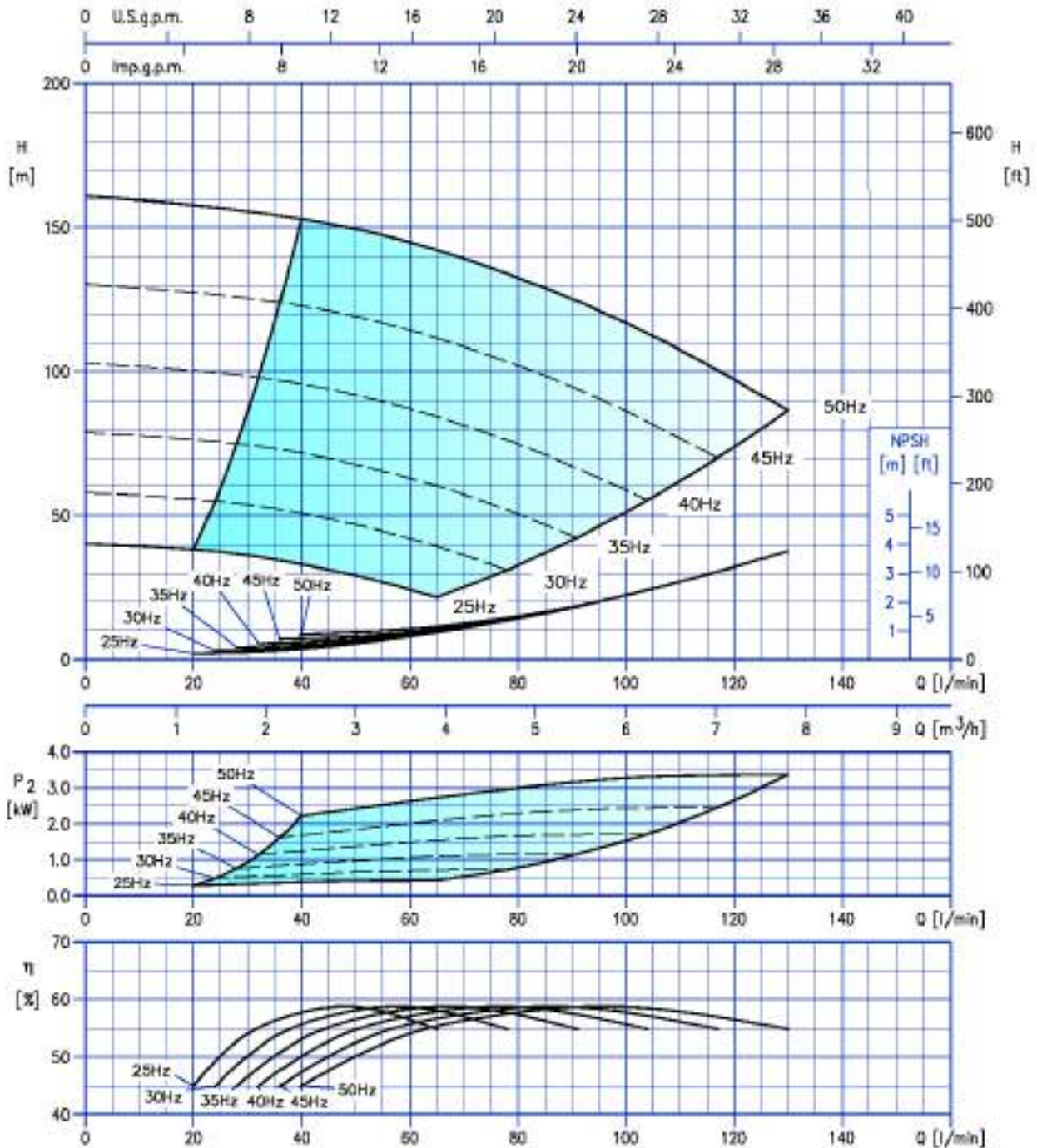

Test standard: ISO 9906: 2012 - Grade 3B

746



### EVMS(.)-K5 19/4.0

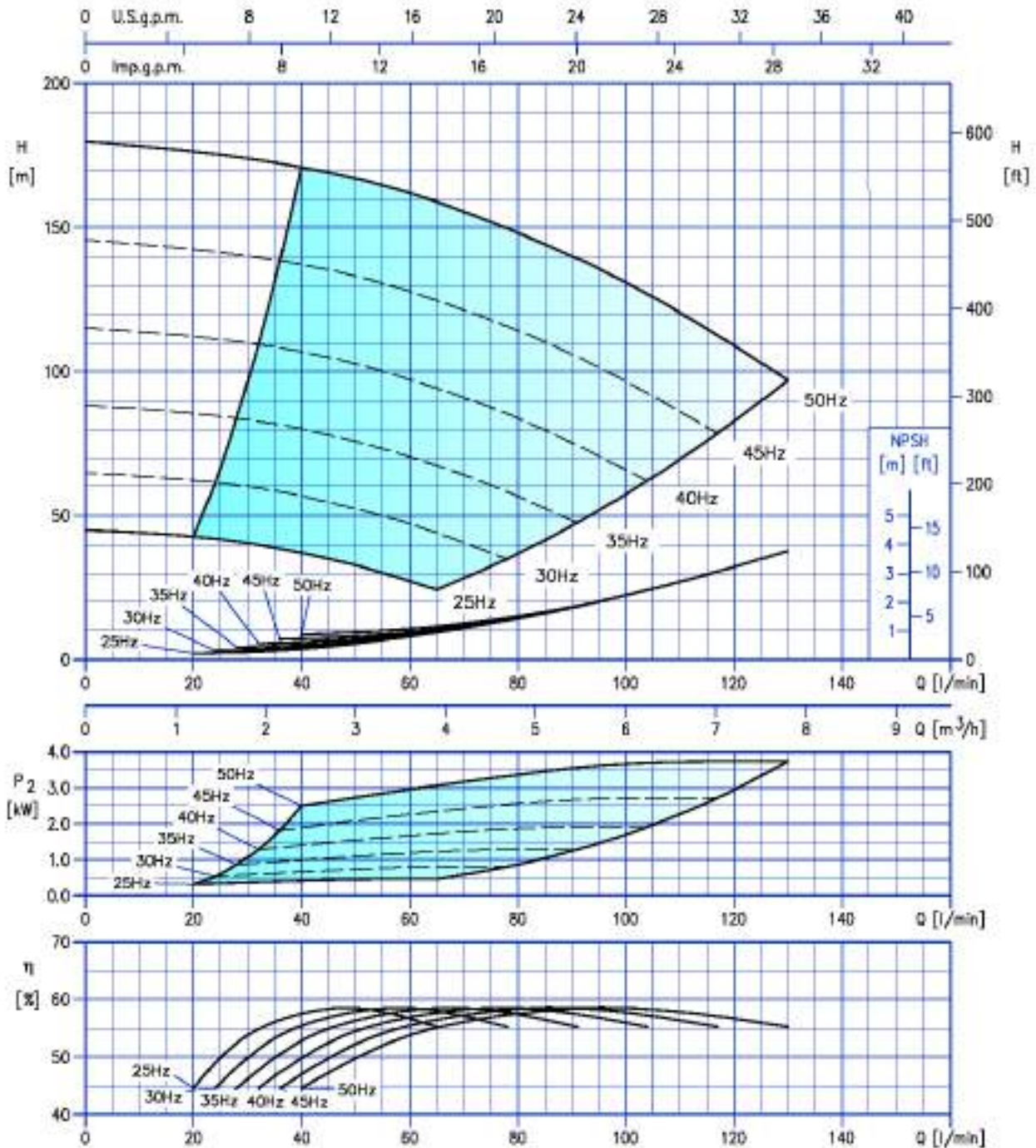

Test standard: ISO 9906: 2012 - Grade 3B

747

### EVMS(.)-K5 20/4.0

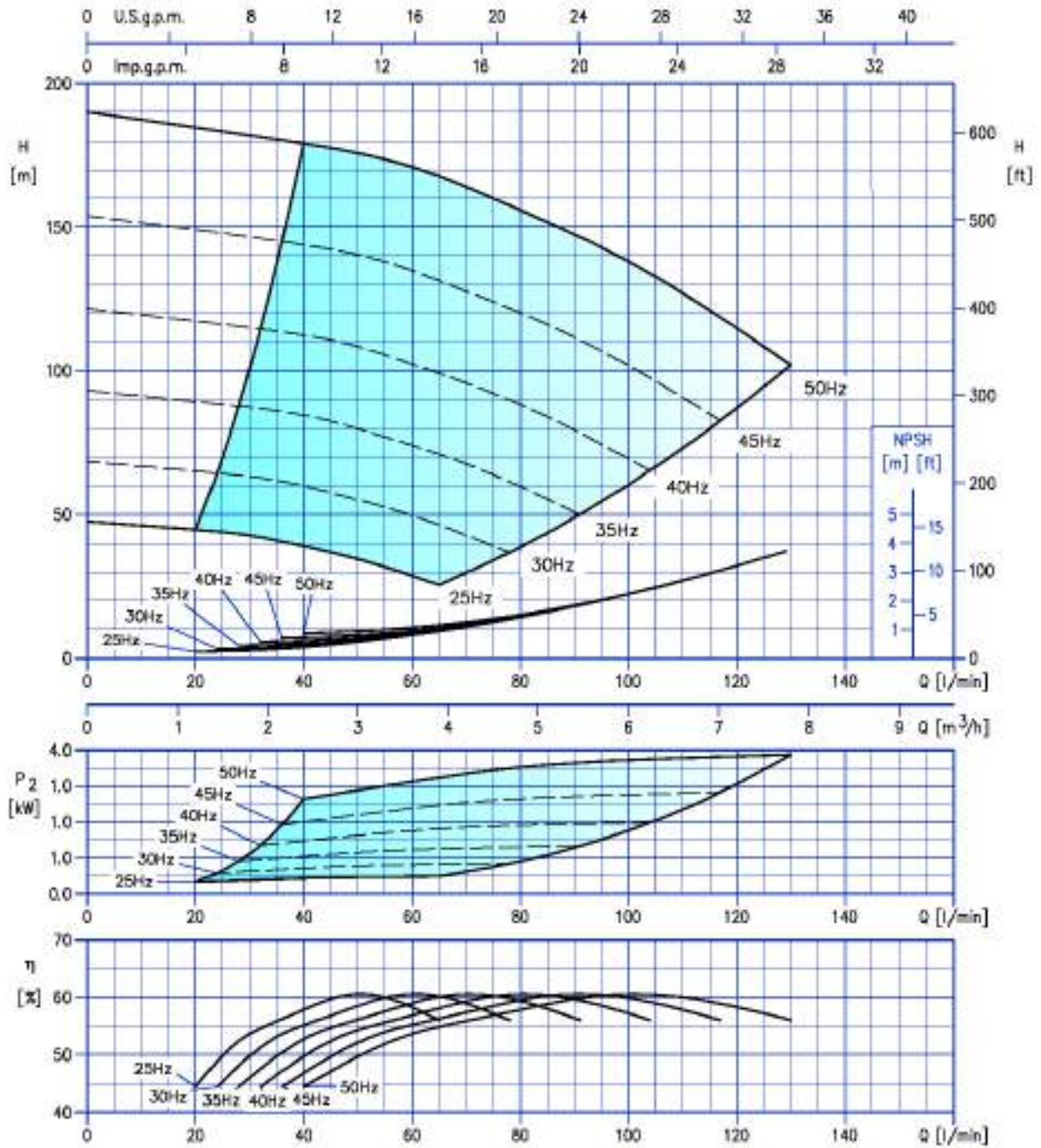

Test standard: ISO 9906: 2012 - Grade 3B

### EVMS(-)-K10 2/0.75

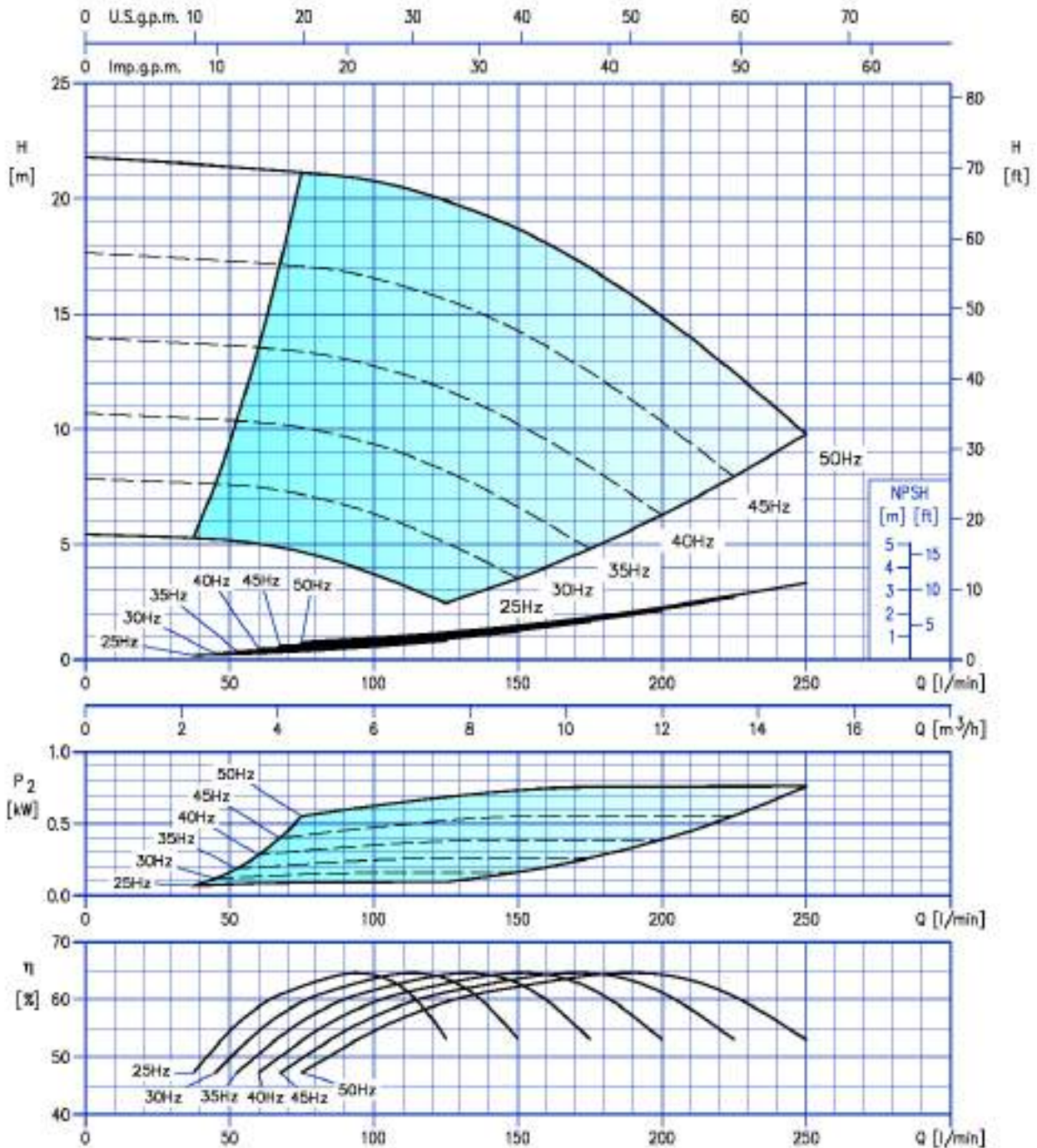

Test standard: ISO 9906: 2012 - Grade 3B

749

### EVMS(.)-K10 3/1.5

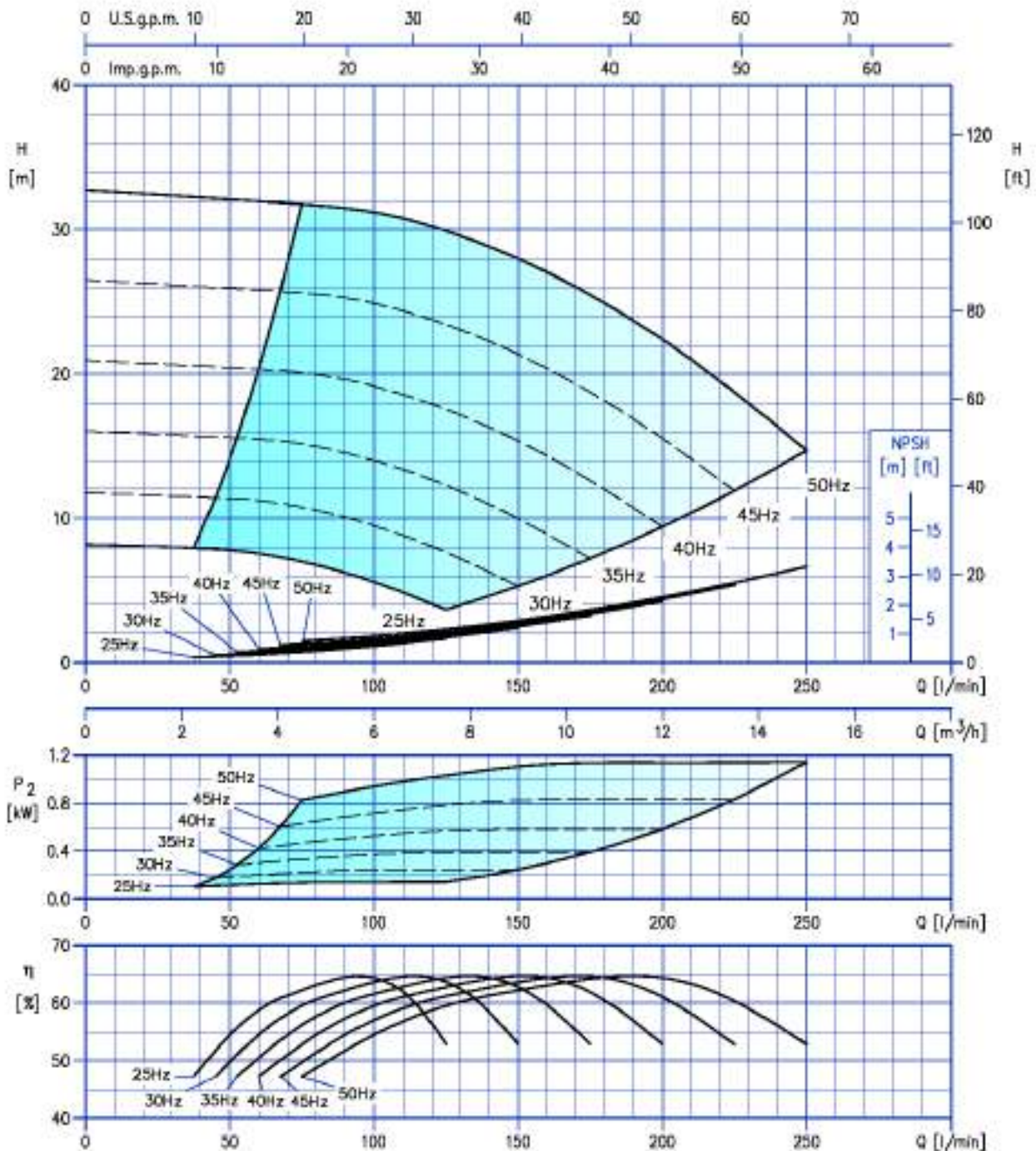

Test standard: ISO 9906: 2012 - Grade 3B

750

### EVMS(.)-K10 4/2.2

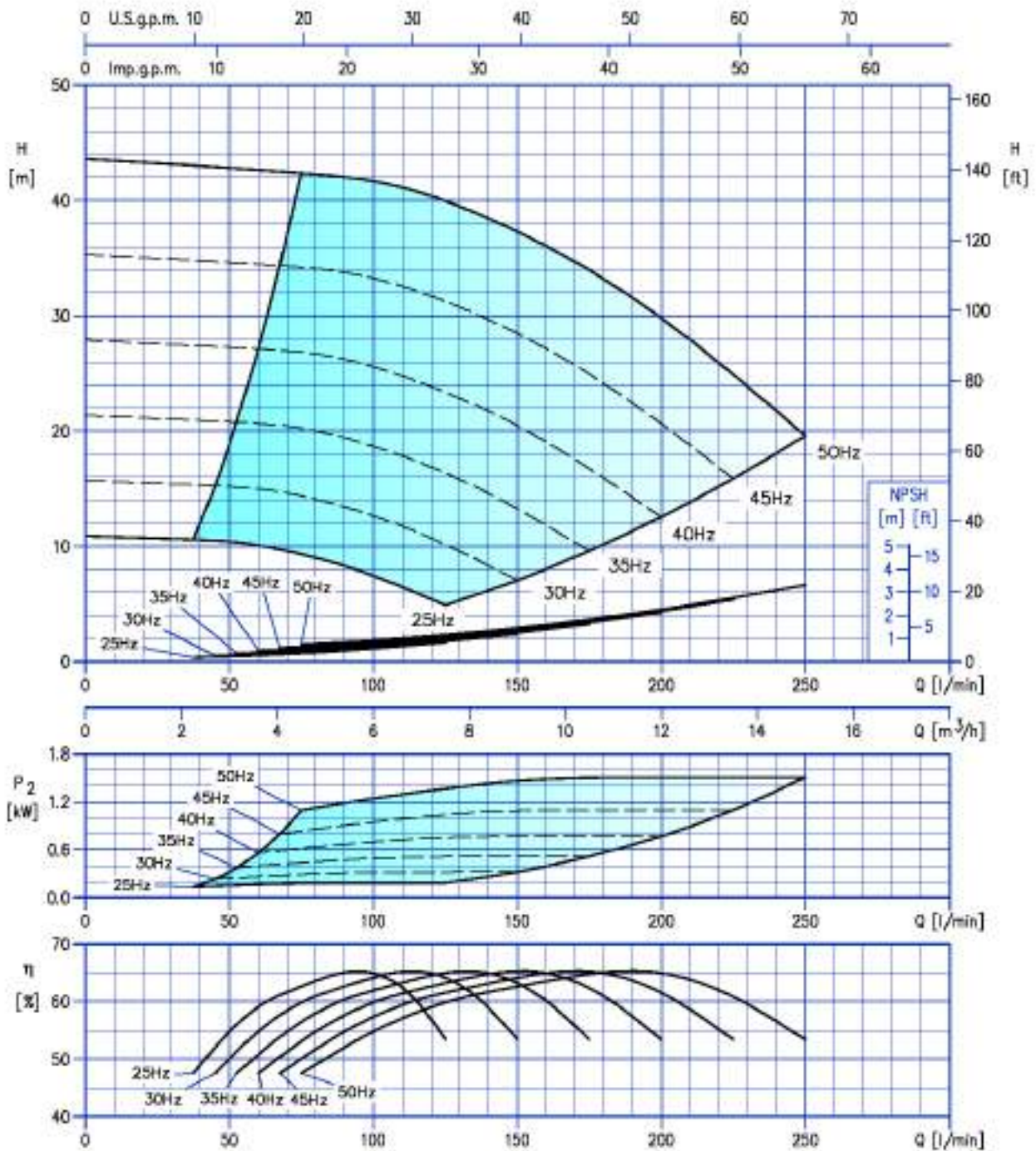

Test standard: ISO 9906: 2012 - Grade 3B

751

### EVMS(.)-K10 5/2.2

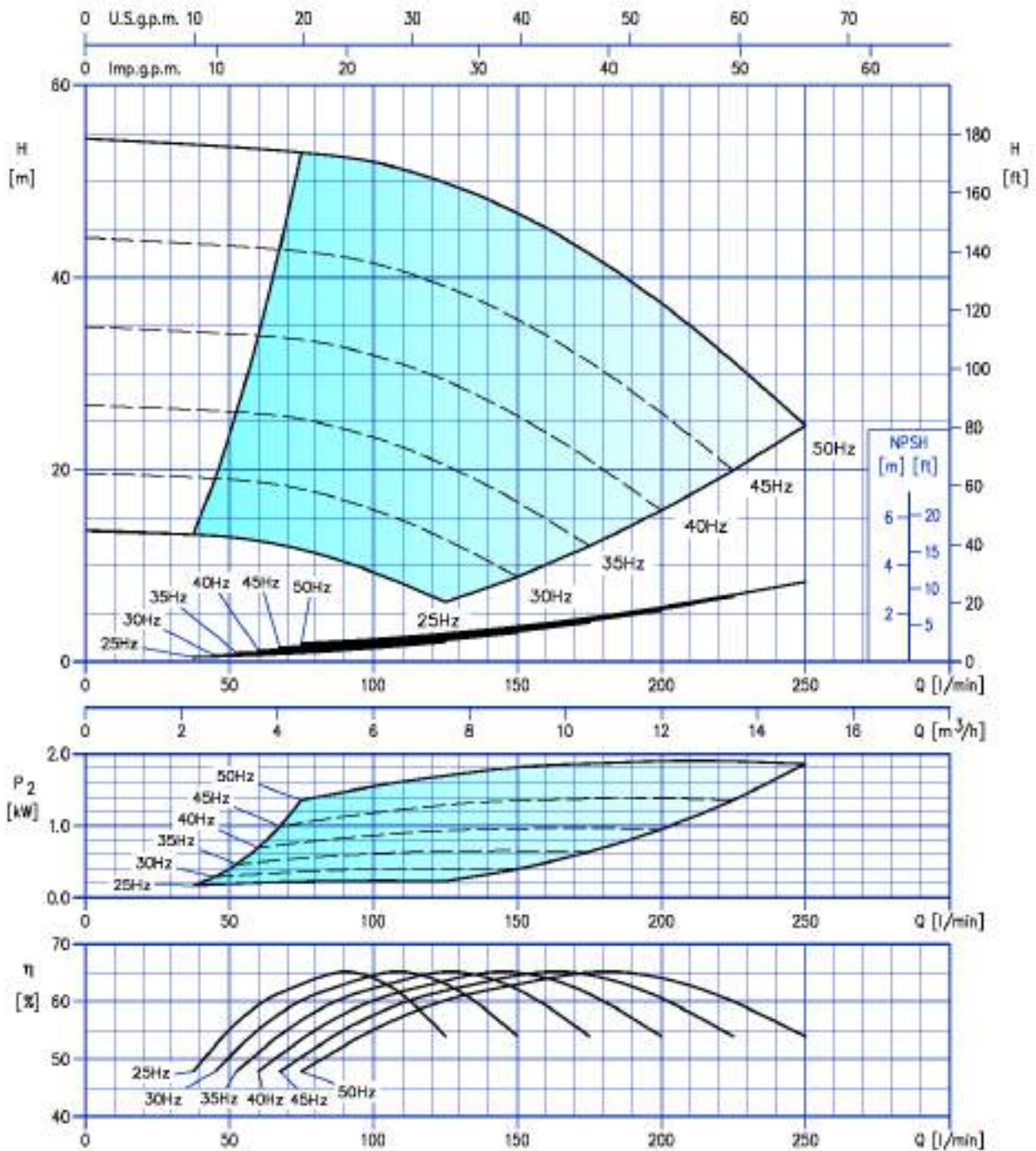

Test standard: ISO 9906: 2012 - Grade 3B

### EVMS(.)-K10 6/2.2

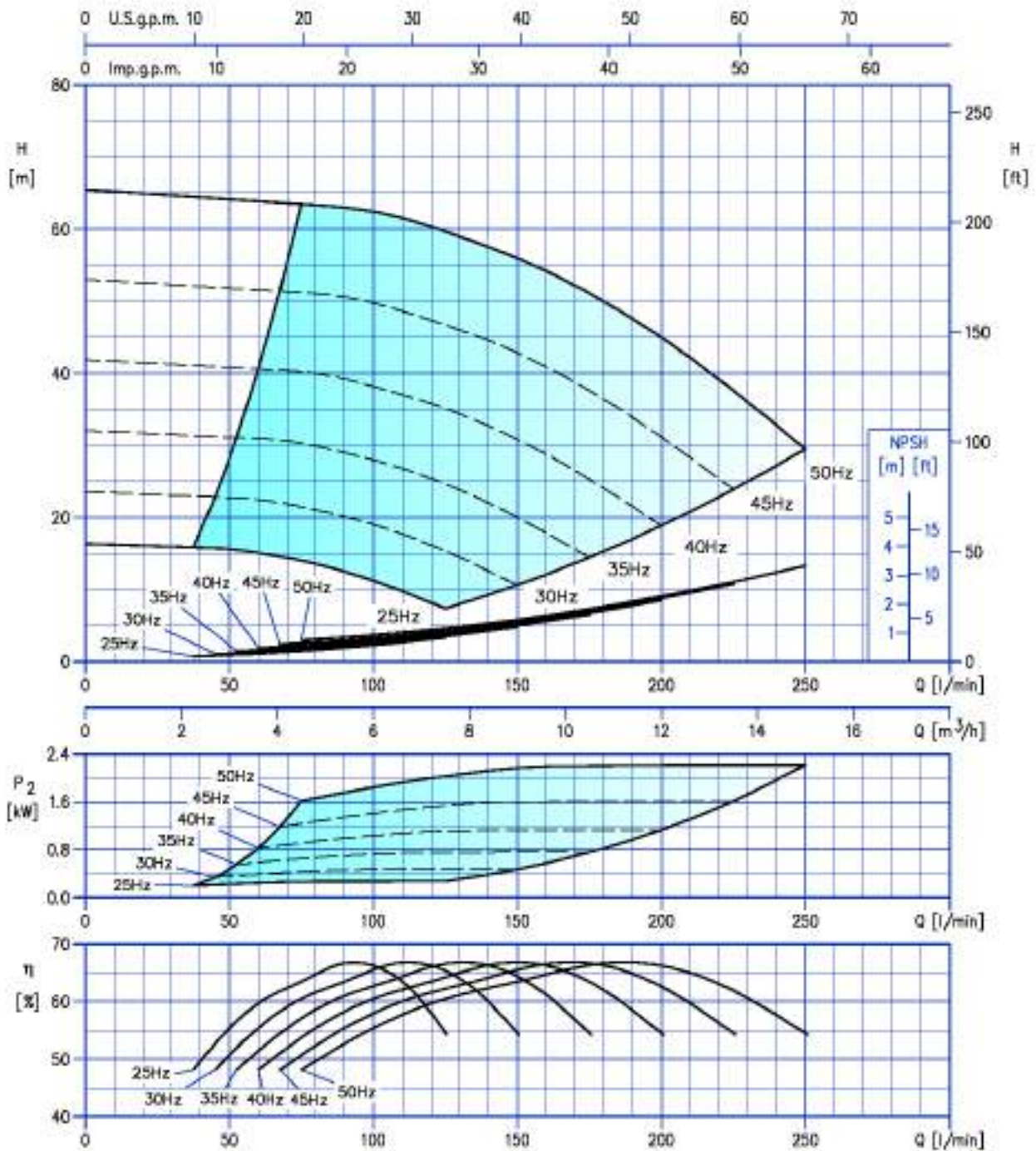

Test standard: ISO 9906: 2012 - Grade 3B

753

### EVMS(.)-K10 7/3.0

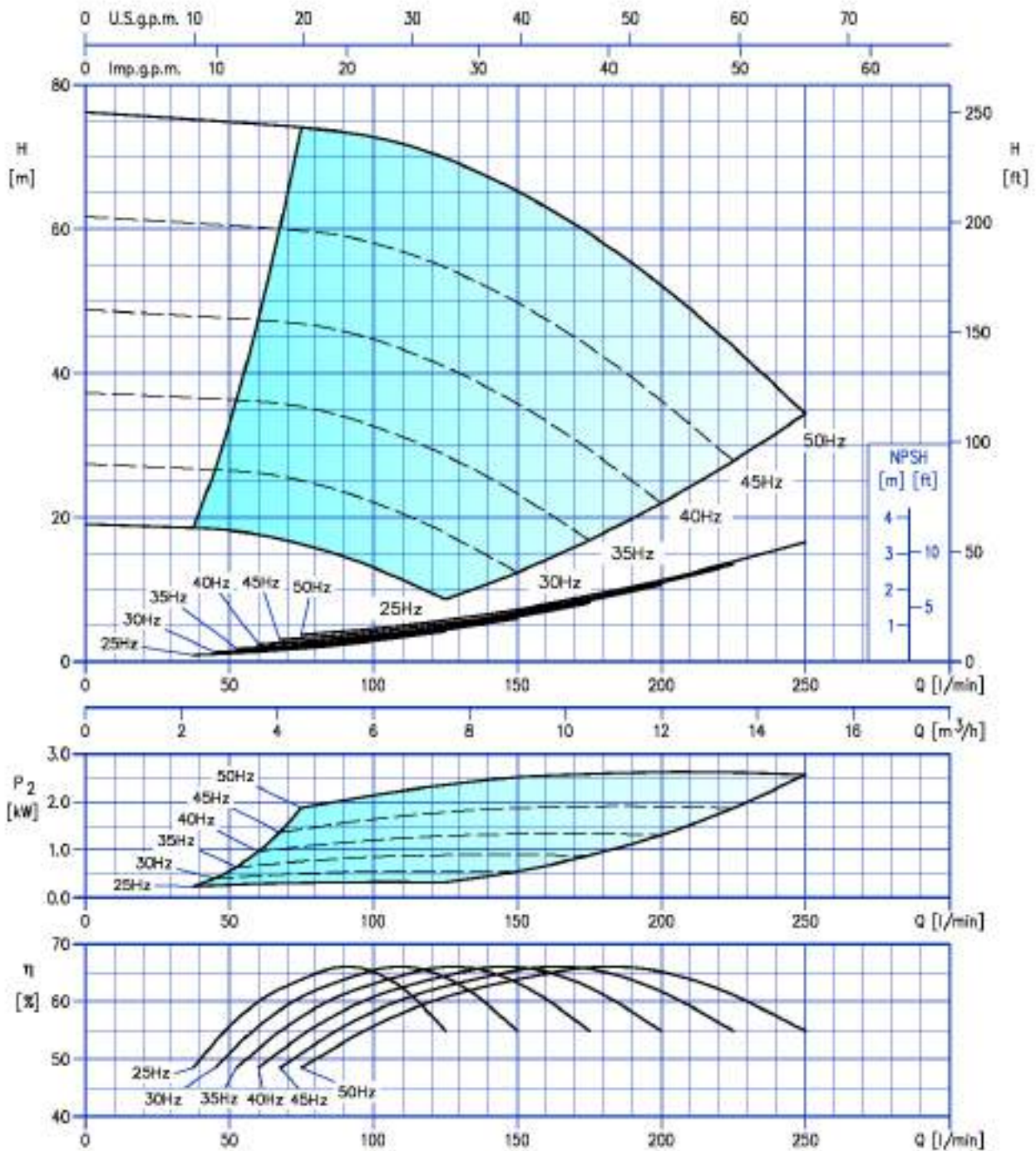

Test standard: ISO 9906: 2012 - Grade 3B

754



### EVMS(.)-K10 8/3.0

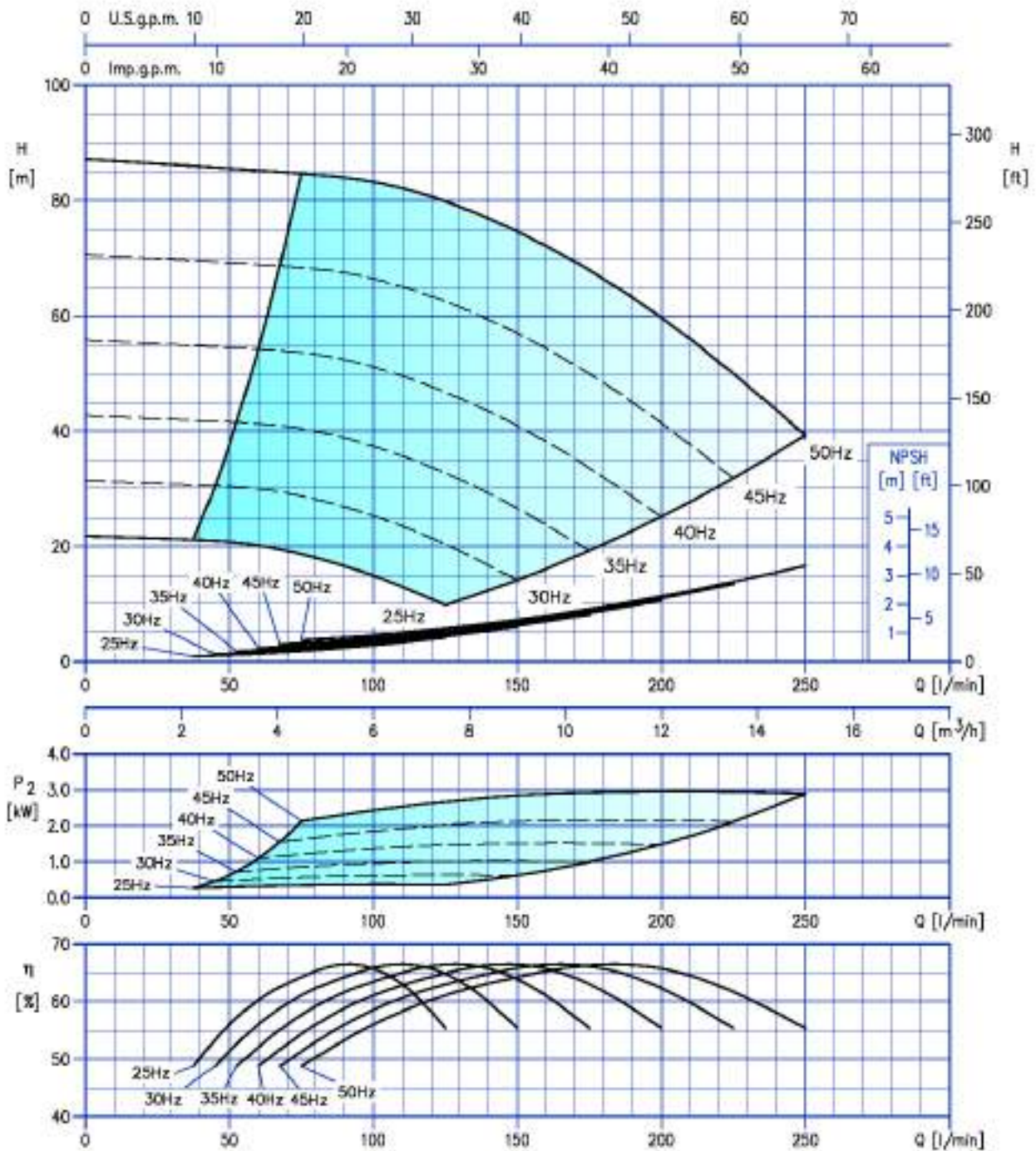

Test standard: ISO 9906: 2012 - Grade 3B

755

### EVMS(.)-K10 9/4.0

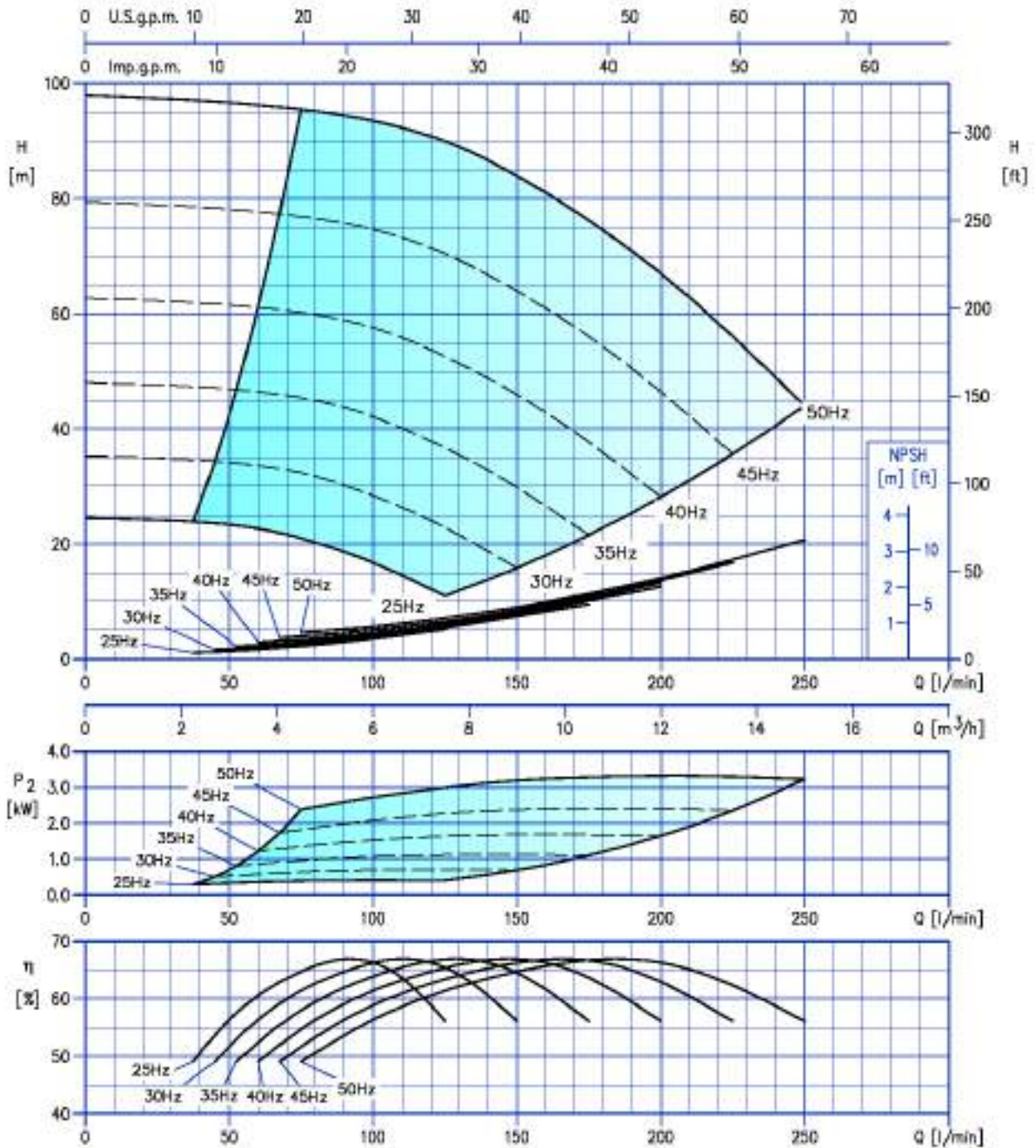

Test standard: ISO 9906: 2012 - Grade 3B

### EVMS(-)-K10 10/4.0

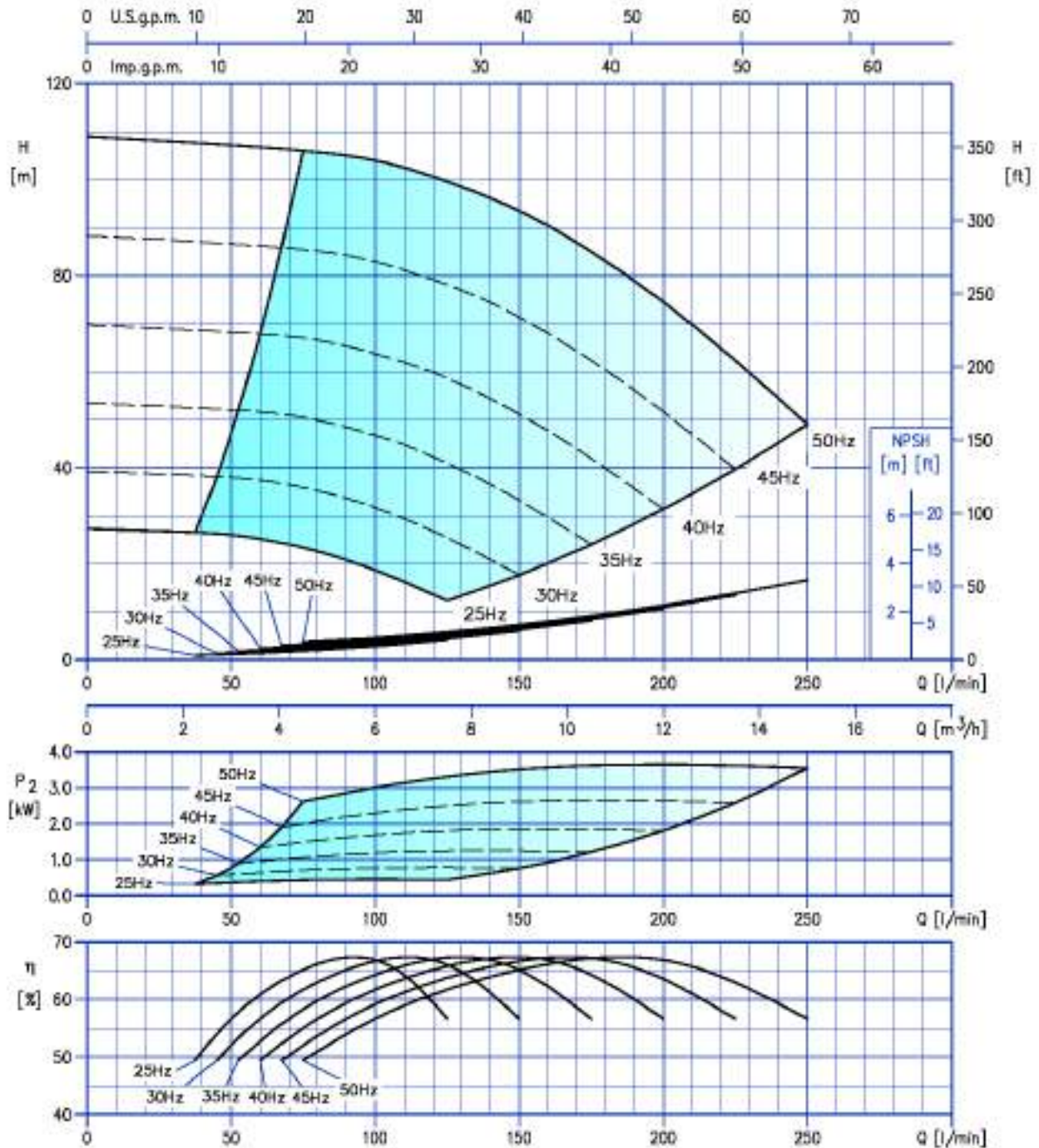

Test standard: ISO 9906: 2012 - Grade 3B

757

### EVMS(-)-K10 11/4.0

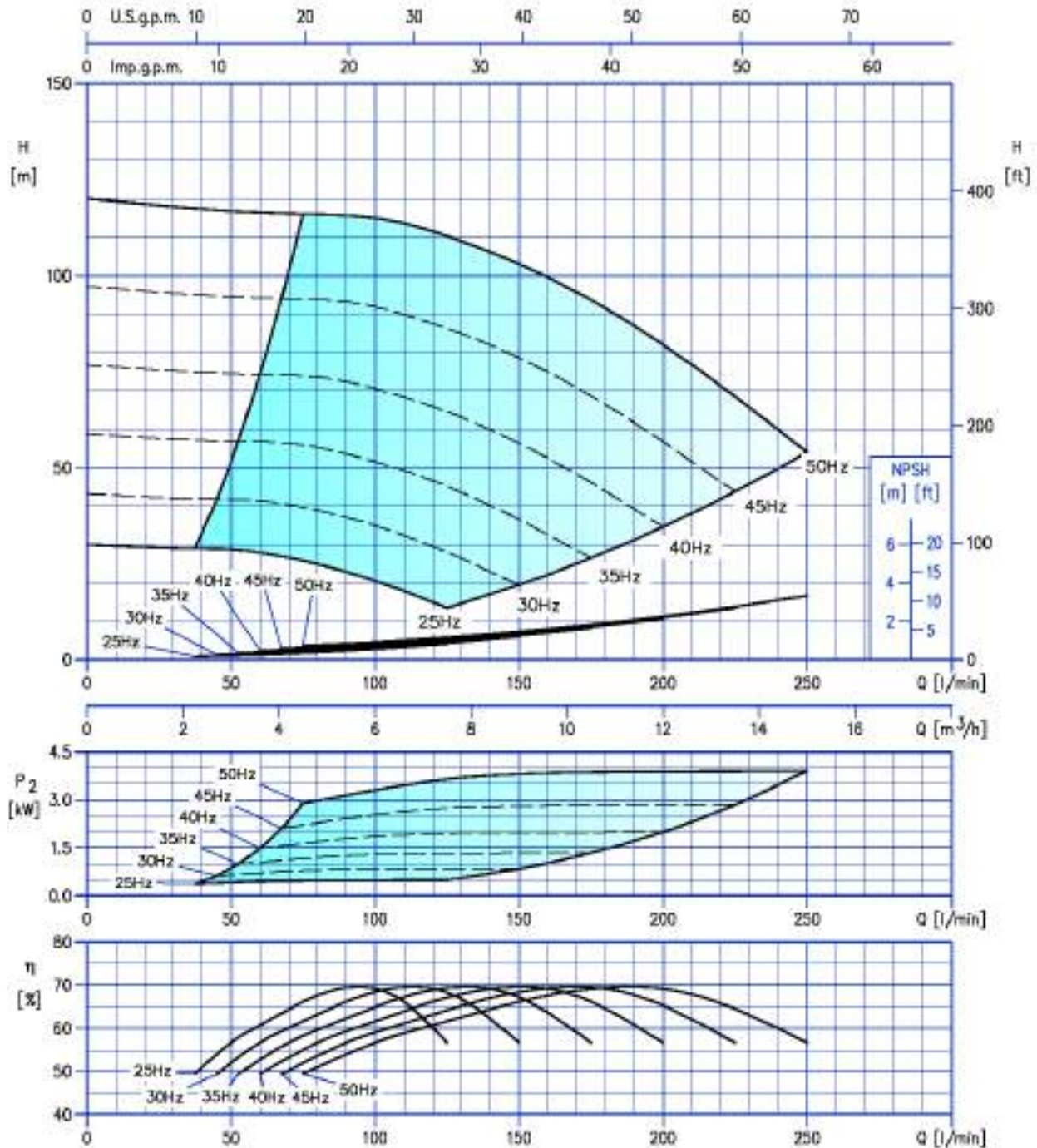

Test standard: ISO 9906: 2012 - Grade 3B

### EVMS(.)-K15 1/1.1

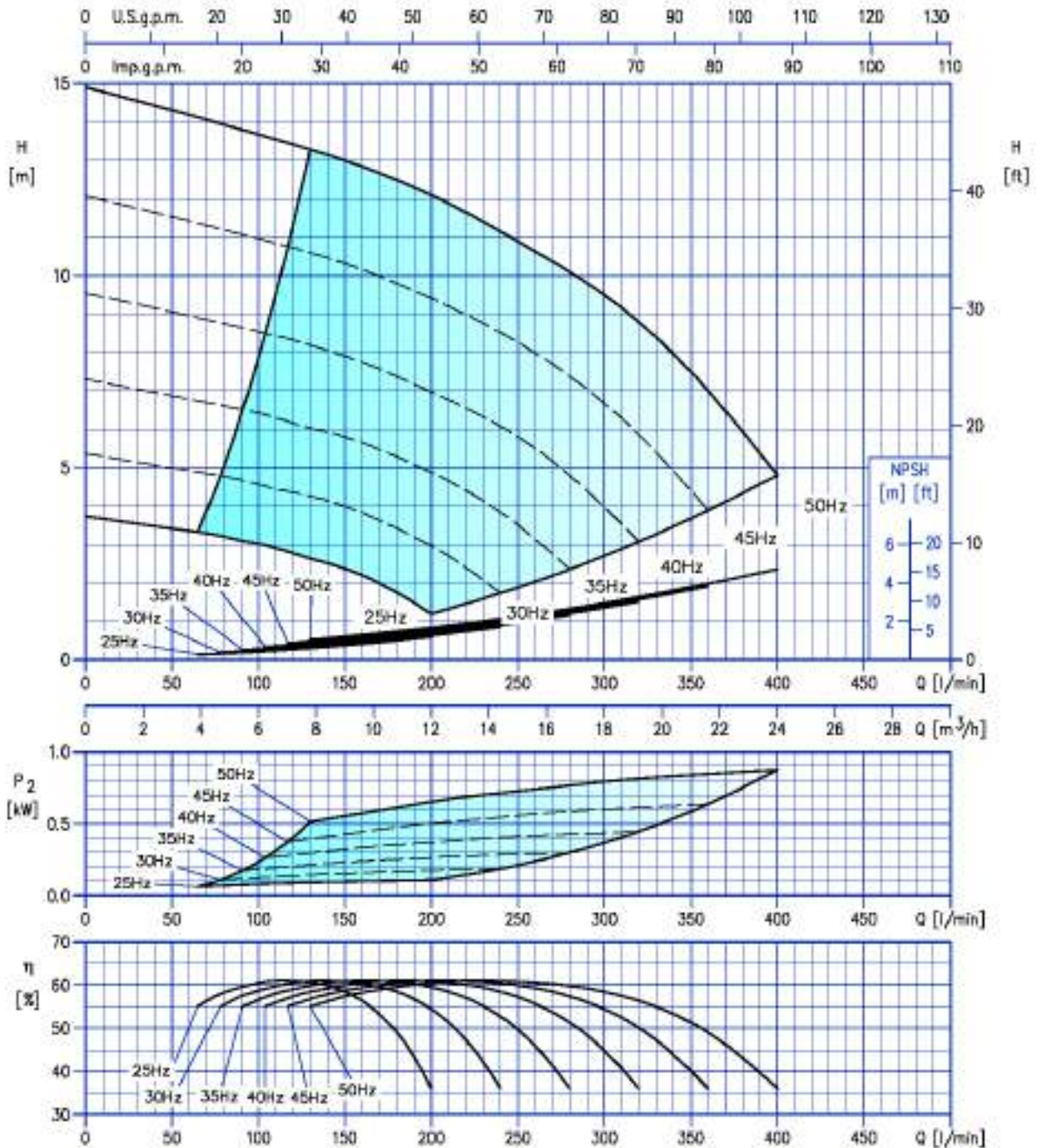

Test standard: ISO 9906: 2012 - Grade 3B

### EVMS(.)-K15 2/2.2

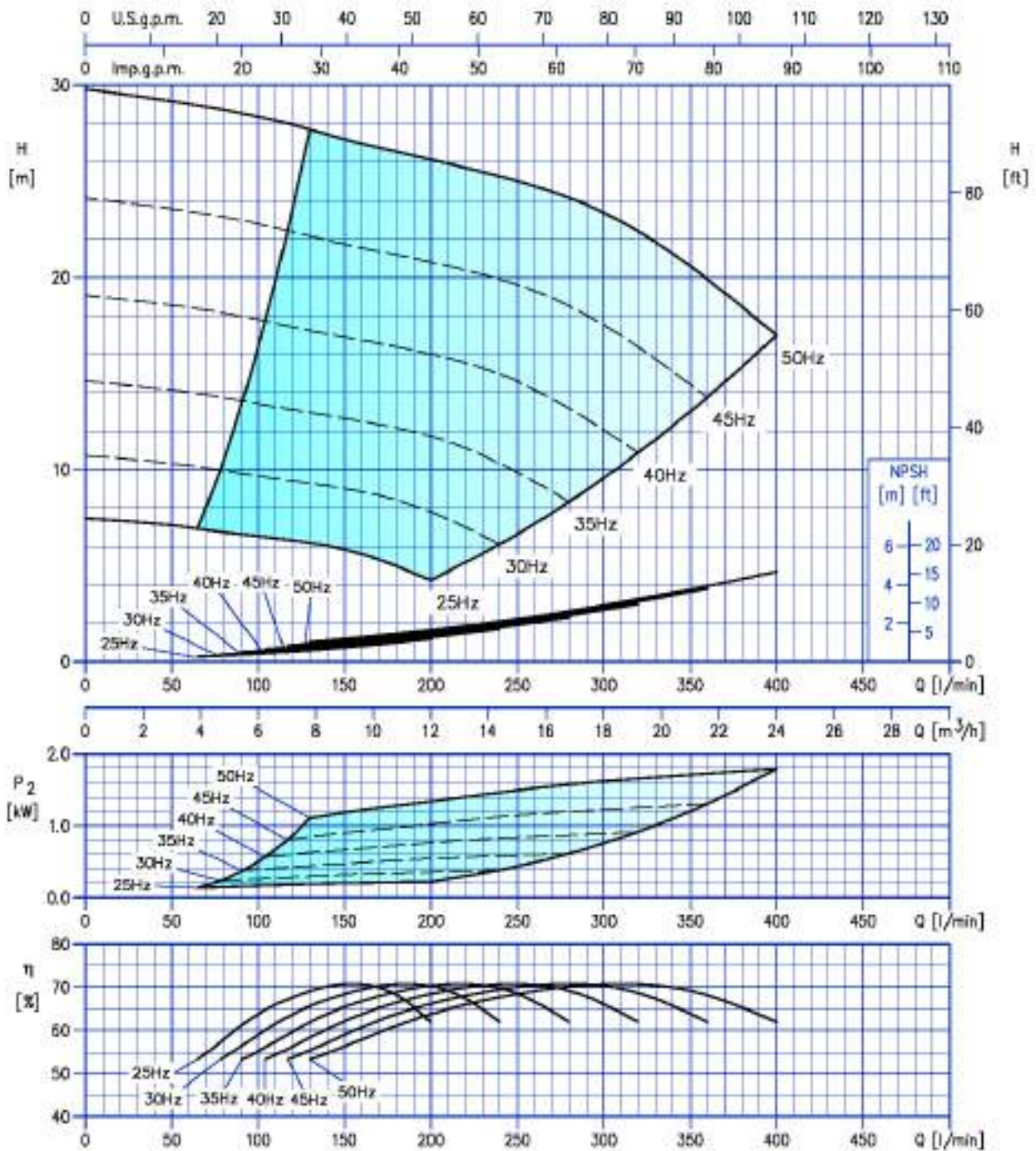

Test standard: ISO 9906: 2012 - Grade 3B

760

### EVMS(.)-K15 3/3.0

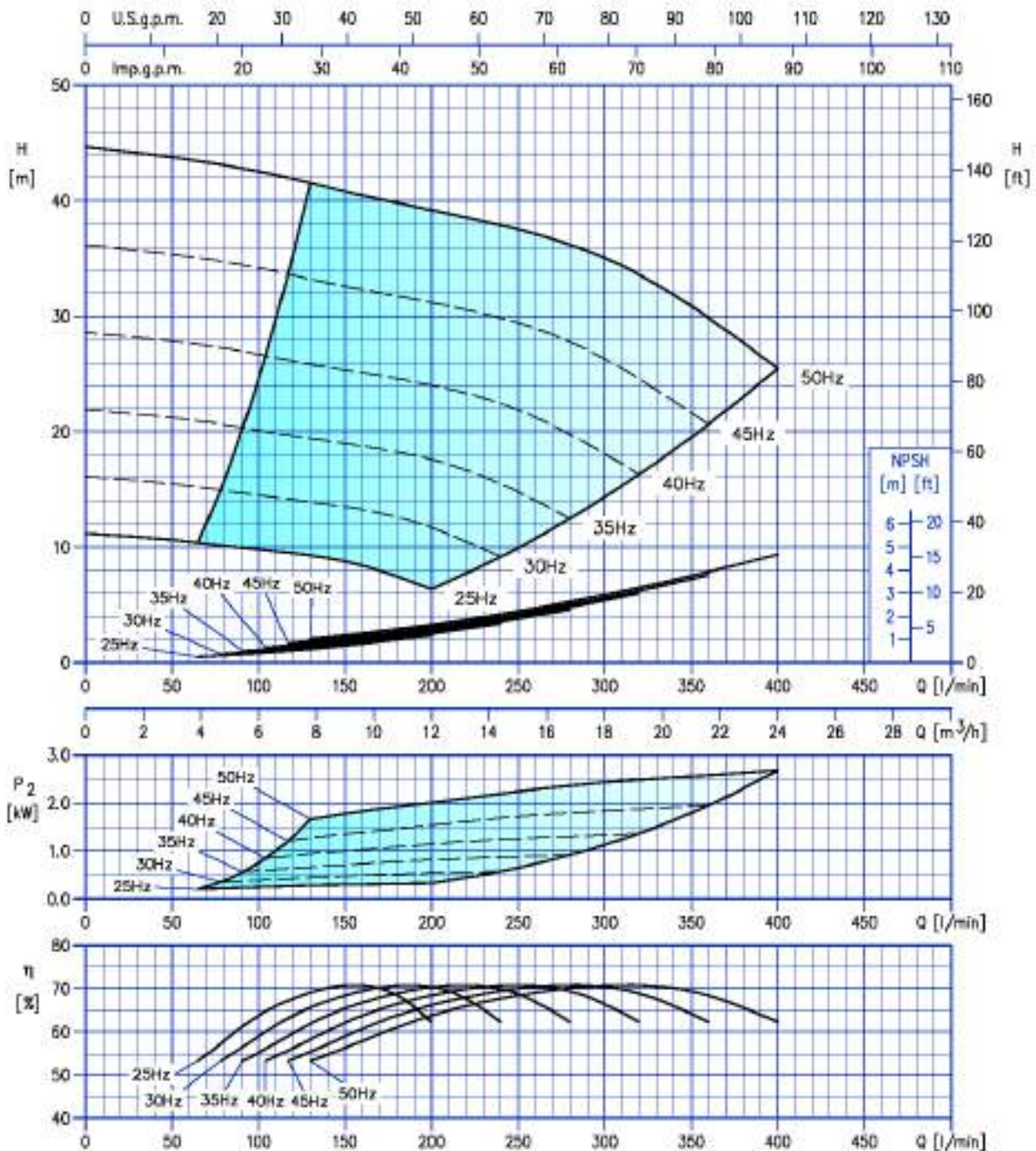

Test standard: ISO 9906: 2012 - Grade 3B

761

### EVMS(.)-K15 4/4.0

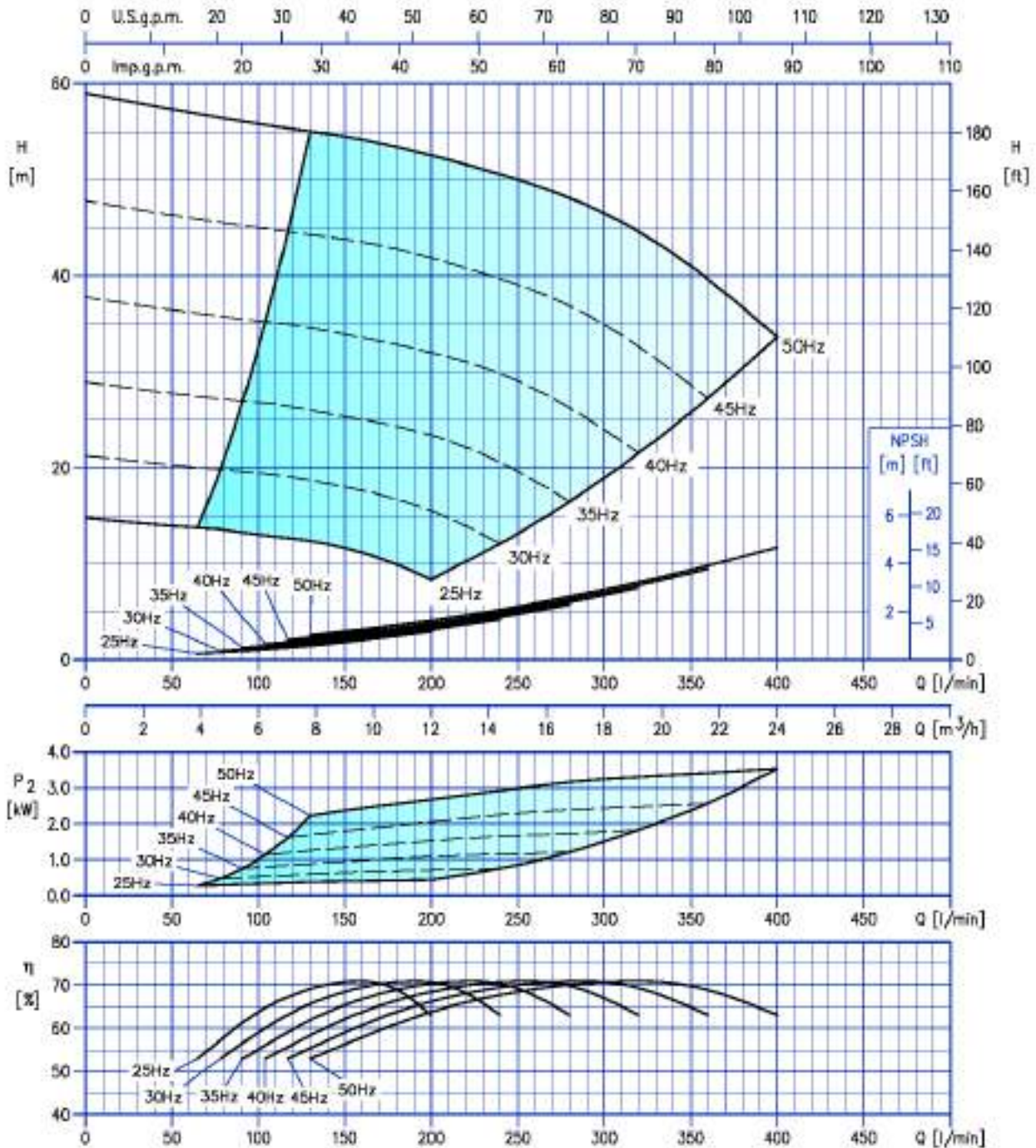

Test standard: ISO 9906: 2012 - Grade 3B



### EVMS(.)-K20 1/1.5

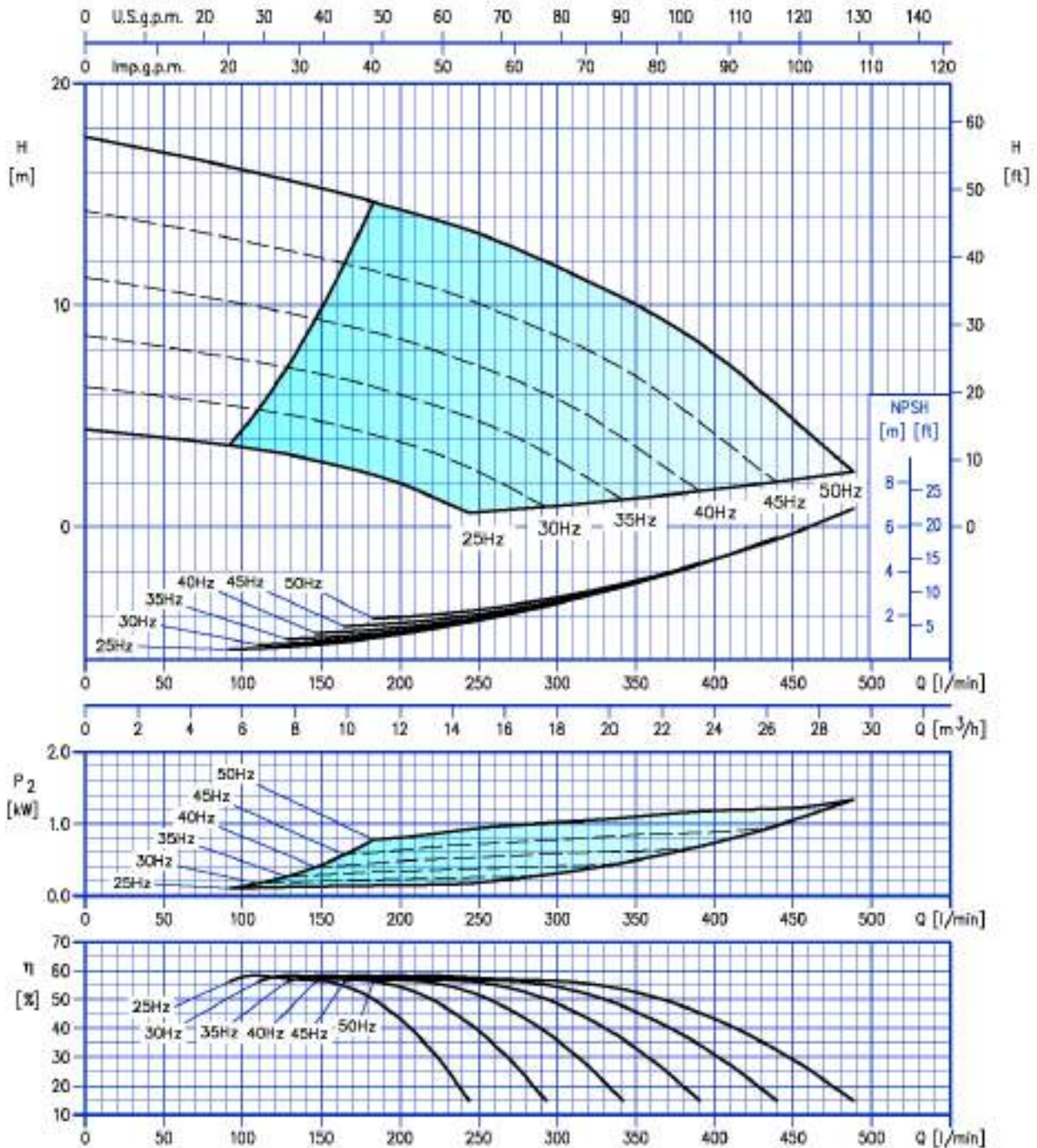

Test standard: ISO 9906: 2012 - Grade 3B

763

### EVMS(.)-K20 2/3.0

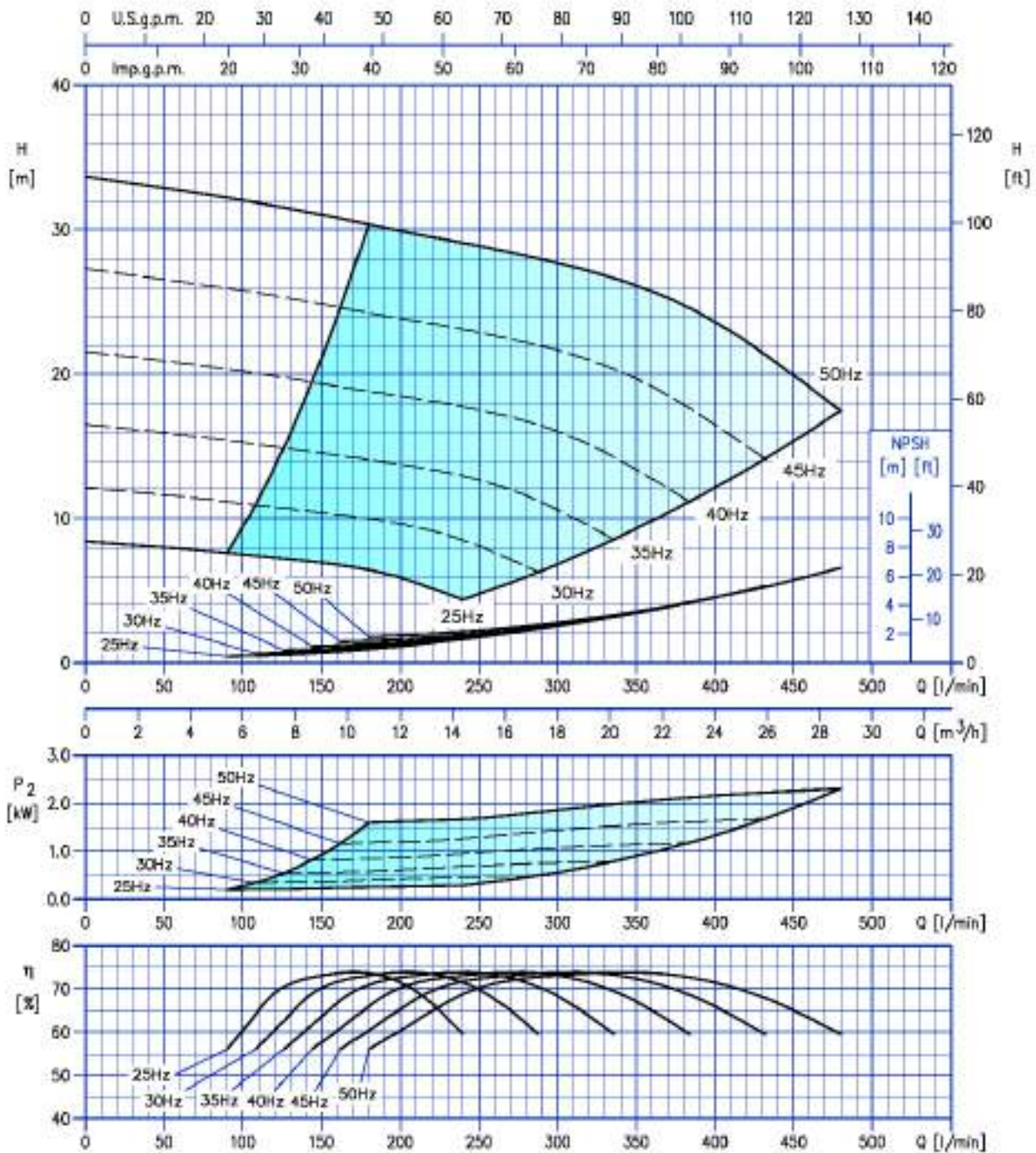

Test standard: ISO 9906: 2012 - Grade 3B

### EVMS(.)-K20 3/4.0

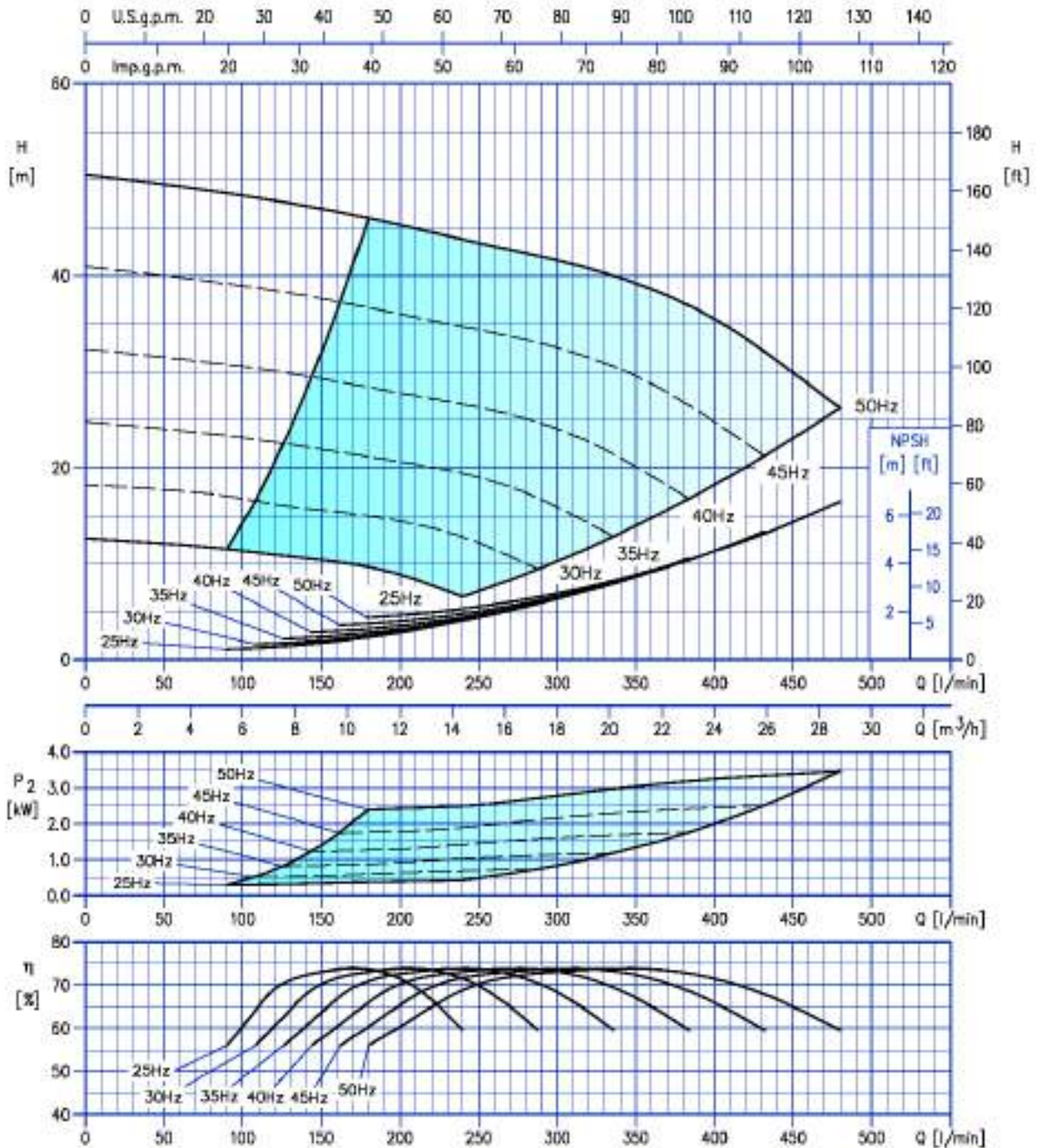

Test standard: ISO 9906: 2012 - Grade 3B

**765**

### PUMP WITH INVERTER CONSTRUCTION

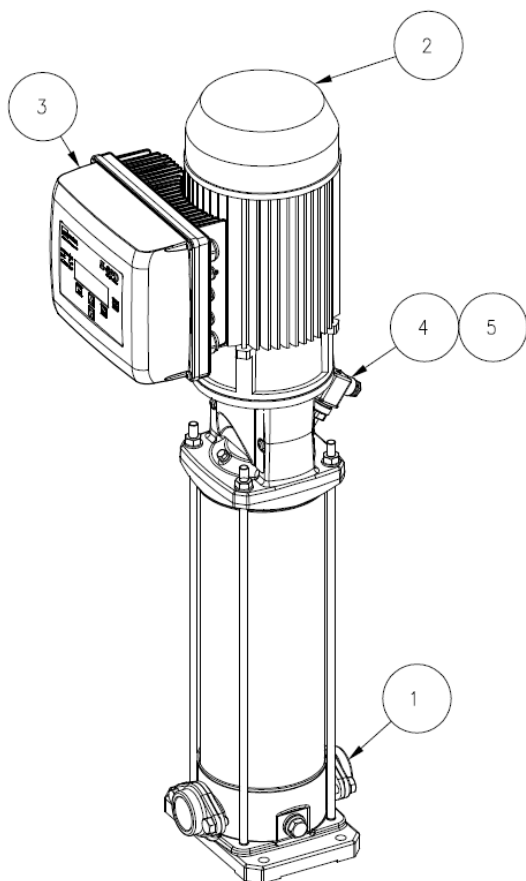

Oval flange (N)

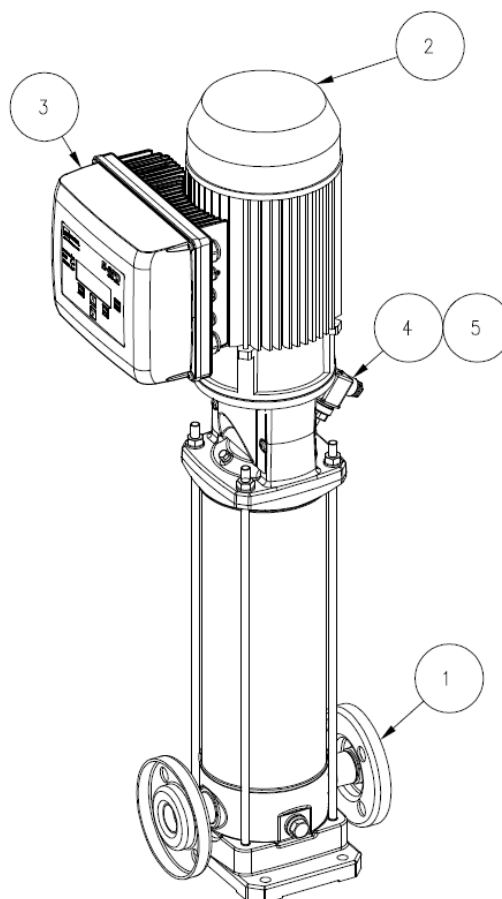

Round flange (F)

N°	PART NAME	Quantity
1	Pump	1
2	Electric motor	1
3	E-SPD	1
4	Pressure transducer [1]	1
5	Stainless steel reducer [2]	1

[1] Only electrically connected

[2] Not assembled

### OVERALL DIMENSIONS PUMP WITH INVERTER

#### EVMS(L)-K1

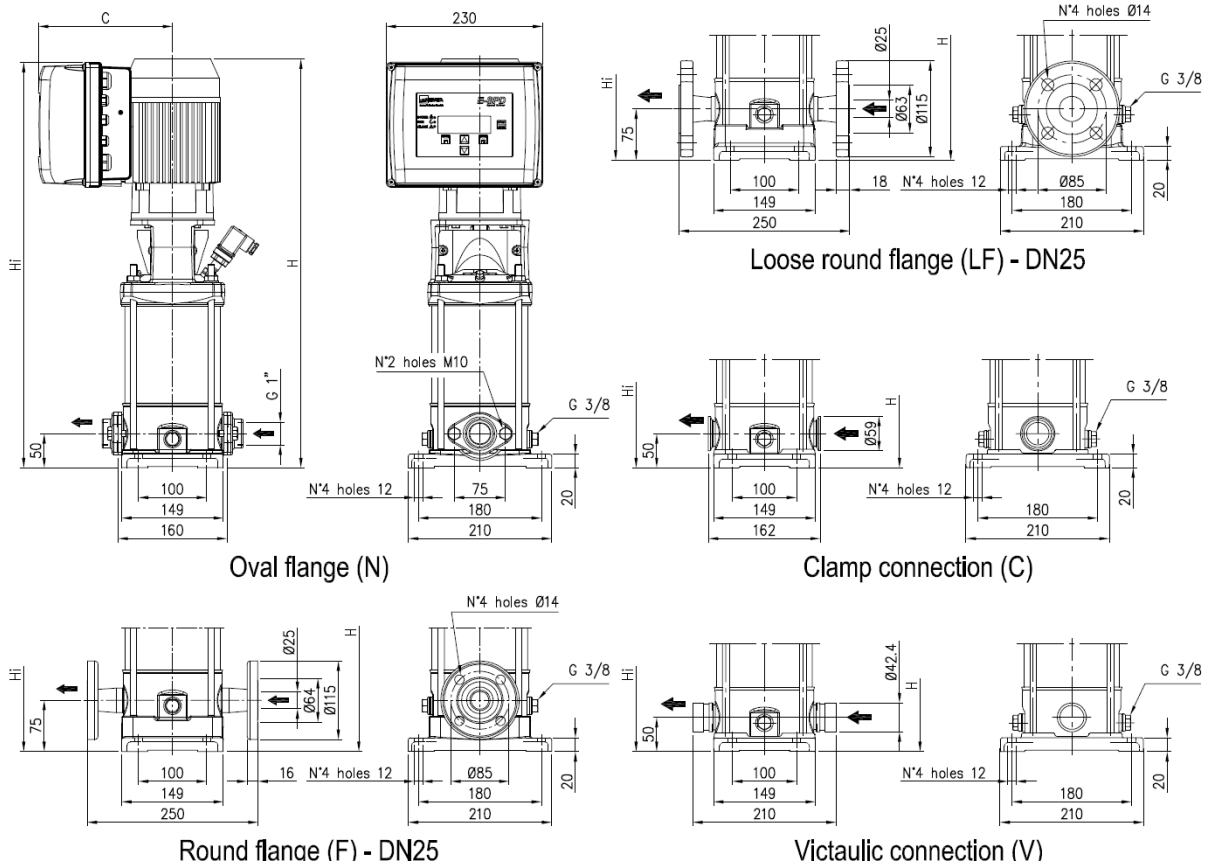

Pump with Inverter	kW	C	Dimensions [mm]								
			Oval flange (N)			Victaulic® connection (V) Clamp connection (C)			Loose Round flange (LF) Round flange (F)		
			H	Hi	Weight [kg]	H	Hi	Weight [kg]	H	Hi	Weight [kg]
EVMS(L)-K1 14/0.75 (.)T	0.75	191	745	740	26.9	745	740	26.9	770	765	27.6
EVMS(L)-K1 16/0.75 (.)T	0.75	191	787	782	27.9	787	782	27.9	812	807	28.6
EVMS(L)-K1 18/1.1 (.)T	1.1	191	840	824	30.5	840	824	30.5	865	849	31.2
EVMS(L)-K1 20/1.1 (.)T	1.1	191	882	866	31.5	882	866	31.5	907	891	32.2
EVMS(L)-K1 22/1.1 (.)T	1.1	191	924	908	32.7	924	908	32.7	949	933	33.4
EVMS(L)-K1 24/1.1 (.)T	1.1	191	966	950	33.7	966	950	33.7	991	975	34.4
EVMS(L)-K1 26/1.1 (.)T	1.1	191	1008	992	34.7	1008	992	34.7	1033	1017	35.4
EVMS(L)-K1 27/1.5 (.)T	1.5	203	-	-	-	1086	1041	38.6	1111	1066	39.3
EVMS(L)-K1 29/1.5 (.)T	1.5	203	-	-	-	1128	1083	39.6	1153	1108	40.3
EVMS(L)-K1 32/1.5 (.)T	1.5	203	-	-	-	1191	1146	40.9	1216	1171	41.6
EVMS(L)-K1 34/1.5 (.)T	1.5	203	-	-	-	1233	1188	41.8	1258	1213	42.5
EVMS(L)-K1 37/2.2 (.)T	2.2	203	-	-	-	1296	1250	44.7	1321	1275	45.4
EVMS(L)-K1 39/2.2 (.)T	2.2	203	-	-	-	1338	1293	45.7	1363	1318	46.4

- : not available model

### EVMSG-K1

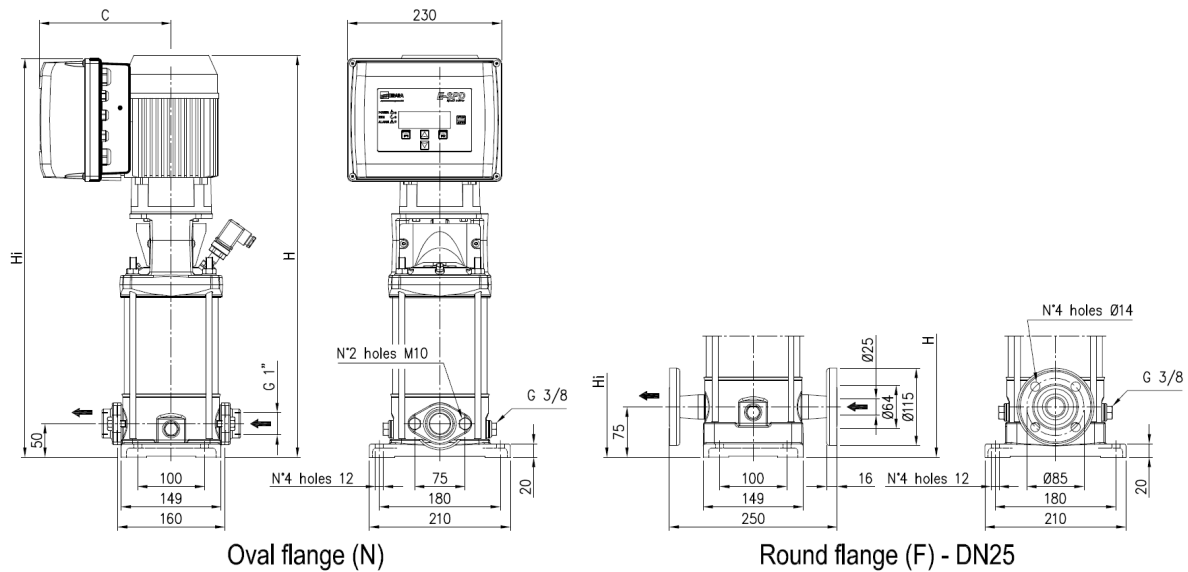

Pump with Inverter	kW	C	Dimensions [mm]					
			Oval flange (N)			Round flange (F)		
			H	Hi	Weight [kg]	H	Hi	Weight [kg]
EVMSG-K1 14/0.75 (.)T	0.75	191	745	740	31.2	770	765	34.6
EVMSG-K1 16/0.75 (.)T	0.75	191	787	782	32.2	812	807	35.6
EVMSG-K1 18/1.1 (.)T	1.1	191	840	824	34.8	865	849	38.2
EVMSG-K1 20/1.1 (.)T	1.1	191	882	866	35.8	907	891	39.2
EVMSG-K1 22/1.1 (.)T	1.1	191	924	908	37.0	949	933	40.4
EVMSG-K1 24/1.1 (.)T	1.1	191	966	950	38.0	991	975	41.4
EVMSG-K1 26/1.1 (.)T	1.1	191	1008	992	39.0	1033	1017	42.4
EVMSG-K1 27/1.5 (.)T	1.5	203	-	-	-	1111	1066	46.3
EVMSG-K1 29/1.5 (.)T	1.5	203	-	-	-	1153	1108	47.3
EVMSG-K1 32/1.5 (.)T	1.5	203	-	-	-	1216	1171	48.6
EVMSG-K1 34/1.5 (.)T	1.5	203	-	-	-	1258	1213	49.5
EVMSG-K1 37/2.2 (.)T	2.2	203	-	-	-	1321	1275	52.4
EVMSG-K1 39/2.2 (.)T	2.2	203	-	-	-	1363	1318	53.4

- : not available model

### EVMS(L)-K3

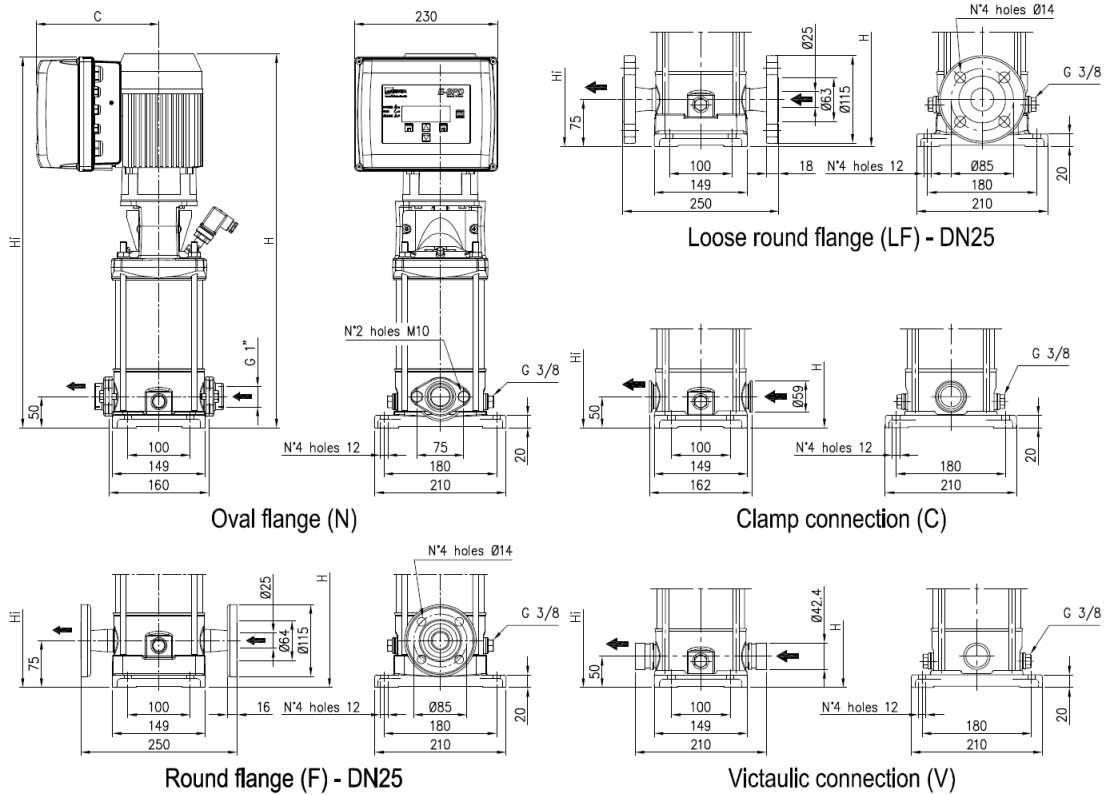

Pump with Inverter	kW	C	Dimensions [mm]								
			Oval flange (N)			Victaulic® connection (V) Clamp connection (C)			Loose Round flange (LF) Round flange (F)		
			H	Hi	Weight [kg]	H	Hi	Weight [kg]	H	Hi	Weight [kg]
EVMS(L)-K3 7/0.75 (.)T	0.75	191	598	593	23.6	598	593	23.6	623	618	24.3
EVMS(L)-K3 8/0.75 (.)T	0.75	191	619	614	24	619	614	24	644	639	24.8
EVMS(L)-K3 9/1.1 (.)T	1.1	191	651	635	25.9	651	635	25.9	676	660	26.7
EVMS(L)-K3 10/1.1 (.)T	1.1	191	672	656	26.4	672	656	26.4	697	681	27.2
EVMS(L)-K3 11/1.1 (.)T	1.1	191	693	677	26.8	693	677	26.8	718	702	27.6
EVMS(L)-K3 12/1.1 (.)T	1.1	191	714	698	27.3	714	698	27.3	739	723	28.1
EVMS(L)-K3 13/1.5 (.)T	1.5	203	792	747	31.5	792	747	31.5	817	772	32.3
EVMS(L)-K3 14/1.5 (.)T	1.5	203	813	768	31.9	813	768	31.9	838	793	32.7
EVMS(L)-K3 15/1.5 (.)T	1.5	203	834	789	32.4	834	789	32.4	859	814	33.2
EVMS(L)-K3 16/1.5 (.)T	1.5	203	855	810	33.5	855	810	33.5	880	835	34.2
EVMS(L)-K3 17/2.2 (.)T	2.2	203	876	831	35.4	876	831	35.4	901	856	36.2
EVMS(L)-K3 19/2.2 (.)T	2.2	203	918	873	36.4	918	873	36.4	943	898	37.2
EVMS(L)-K3 21/2.2 (.)T	2.2	203	960	915	37.3	960	915	37.3	985	940	38.1
EVMS(L)-K3 23/2.2 (.)T	2.2	203	-	-	-	1002	957	38.3	1027	982	39.1
EVMS(L)-K3 24/2.2 (.)T	2.2	203	-	-	-	1023	978	38.8	1048	1003	39.5
EVMS(L)-K3 25/3.0 TT	3.0	210	-	-	-	1105	1009	46.4	1130	1034	47.1
EVMS(L)-K3 27/3.0 TT	3.0	210	-	-	-	1147	1051	47.3	1172	1076	48.1
EVMS(L)-K3 29/3.0 TT	3.0	210	-	-	-	1189	1093	48.3	1214	1118	49
EVMS(L)-K3 31/3.0 TT	3.0	210	-	-	-	1231	1135	49.3	1256	1160	50
EVMS(L)-K3 33/3.0 TT	3.0	210	-	-	-	1273	1177	50.1	1298	1202	50.8

- : not available model

### EVMSG-K3

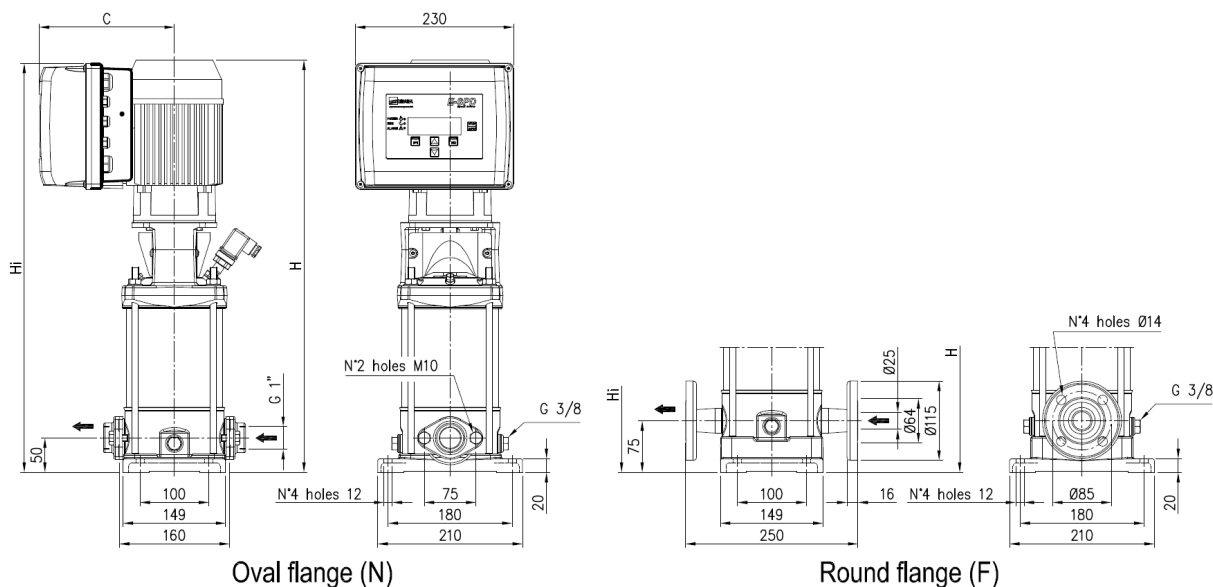

Oval flange (N)

Round flange (F)

Pump with Inverter	Dimensions [mm]							
	kW	C	Oval flange (N)			Round flange (F)		
			H	Hi	Weight [kg]	H	Hi	Weight [kg]
EVMSG-K3 7/0.75 (.).T	0.75	191	598	593	26.8	623	618	29.5
EVMSG-K3 8/0.75 (.).T	0.75	191	619	614	27.2	644	639	30
EVMSG-K3 9/1.1 (.).T	1.1	191	651	635	29.1	676	660	31.9
EVMSG-K3 10/1.1 (.).T	1.1	191	672	656	29.6	697	681	32.4
EVMSG-K3 11/1.1 (.).T	1.1	191	693	677	30.0	718	702	32.8
EVMSG-K3 12/1.1 (.).T	1.1	191	714	698	30.5	739	723	33.3
EVMSG-K3 13/1.5 (.).T	1.5	203	792	747	34.7	817	772	37.5
EVMSG-K3 14/1.5 (.).T	1.5	203	813	768	35.2	838	793	37.9
EVMSG-K3 15/1.5 (.).T	1.5	203	834	789	35.6	859	814	38.4
EVMSG-K3 16/1.5 (.).T	1.5	203	855	810	36.7	880	835	39.4
EVMSG-K3 17/2.2 (.).T	2.2	203	876	831	38.6	901	856	41.4
EVMSG-K3 19/2.2 (.).T	2.2	203	918	873	39.6	943	898	42.4
EVMSG-K3 21/2.2 (.).T	2.2	203	960	915	40.5	985	940	43.3
EVMSG-K3 23/2.2 (.).T	2.2	203	-	-	-	1027	982	44.3
EVMSG-K3 24/2.2 (.).T	2.2	203	-	-	-	1048	1003	44.7
EVMSG-K3 25/3.0 TT	3.0	210	-	-	-	1130	1034	52.3
EVMSG-K3 27/3.0 TT	3.0	210	-	-	-	1172	1076	53.3
EVMSG-K3 29/3.0 TT	3.0	210	-	-	-	1214	1118	54.3
EVMSG-K3 31/3.0 TT	3.0	210	-	-	-	1256	1160	55.2
EVMSG-K3 33/3.0 TT	3.0	210	-	-	-	1298	1202	56

- : not available model



### EVMS(L)-K5

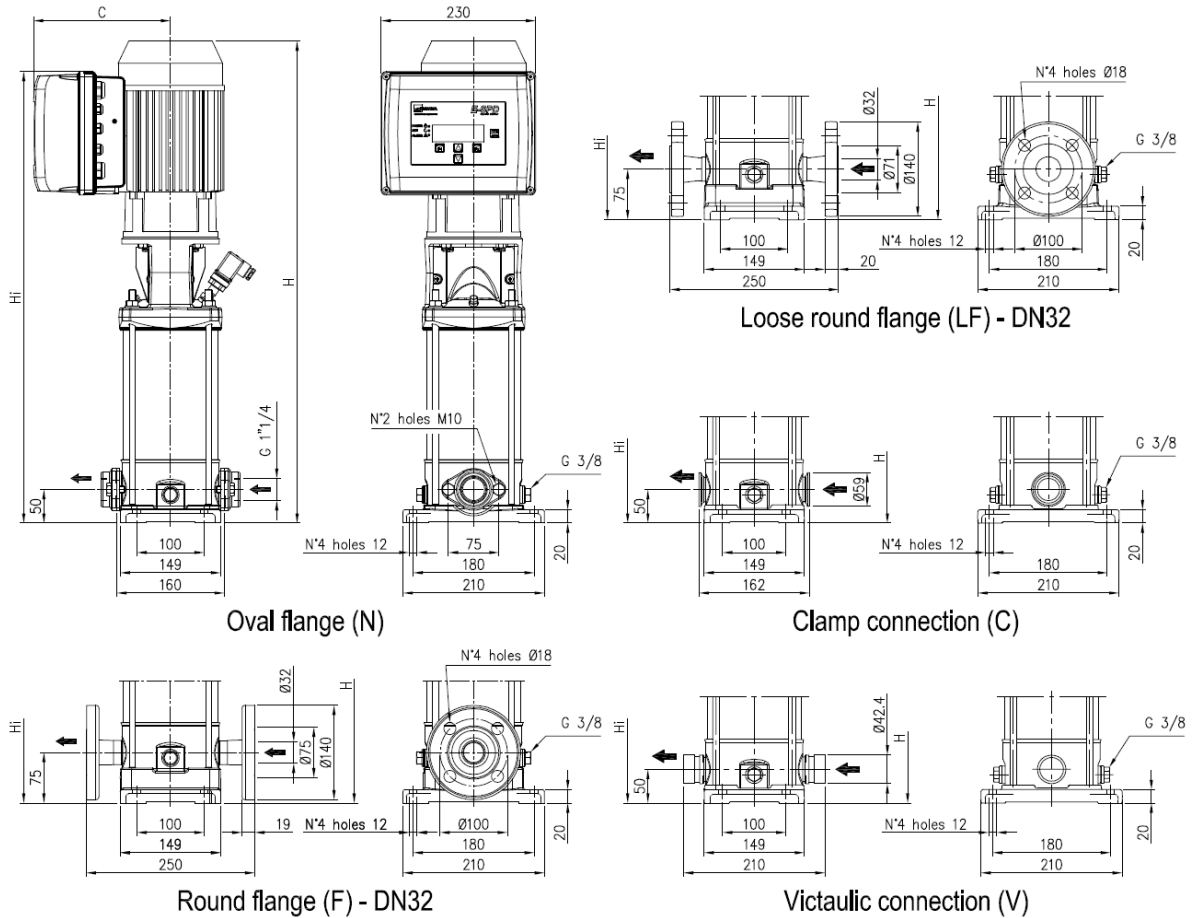

DIMENSION AND WEIGHT

Pump with Inverter	Dimensions [mm]									
	kW	C	Oval flange (N)				Round flange (F)			
			H	Hi	Weight EVMS(L)-K [kg]	Weight EVMSG-K [kg]	H	Hi	Weight EVMS(L)-K [kg]	Weight EVMSG-K [kg]
EVMS(.)-K5 4/0.75 TT (MT)	0.75	191	563	558	22.5	25.7	588	583	23.7	30.2
EVMS(.)-K5 5/1.1 TT (MT)	1.1	191	602	586	24.5	27.7	627	611	25.7	32.2
EVMS(.)-K5 6/1.5 TT (MT)	1.5	203	687	642	28.9	31.7	712	667	29.9	36.3
EVMS(.)-K5 7/1.5 TT (MT)	1.5	203	715	670	29	32.2	740	695	30.3	36.7
EVMS(.)-K5 8/2.2 TT (MT)	2.2	203	743	698	31.1	34.3	768	723	32.3	38.8
EVMS(.)-K5 9/2.2 TT (MT)	2.2	203	771	726	31.6	34.8	796	751	32.9	39.3
EVMS(.)-K5 10/2.2 TT (MT)	2.2	203	799	754	32.1	35.3	824	779	33.3	39.8
EVMS(.)-K5 11/2.2 TT (MT)	2.2	203	827	782	32.9	36.1	852	807	34.2	40.6
EVMS(.)-K5 12/3.0 TT	3.0	210	916	820	41.4	44.3	941	845	42.4	48.8
EVMS(.)-K5 13/3.0 TT	3.0	210	944	848	41.7	44.9	969	873	43	49.4
EVMS(.)-K5 14/3.0 TT	3.0	210	972	876	42.3	45.5	997	901	50.7	50
EVMS(.)-K5 15/3.0 TT	3.0	210	1000	904	43.3	46.5	1025	929	44.6	51
EVMS(.)-K5 17/4.0 TT	4.0	225	1078	959	50.5	53.7	1103	984	51.8	58.2
EVMS(.)-K5 19/4.0 TT	4.0	225	-	-	-	-	1159	1040	52.9	59.3
EVMS(.)-K5 20/4.0 TT	4.0	225	-	-	-	-	1187	1068	55.1	61.5

-- : not available model

771

### EVMSG-K5

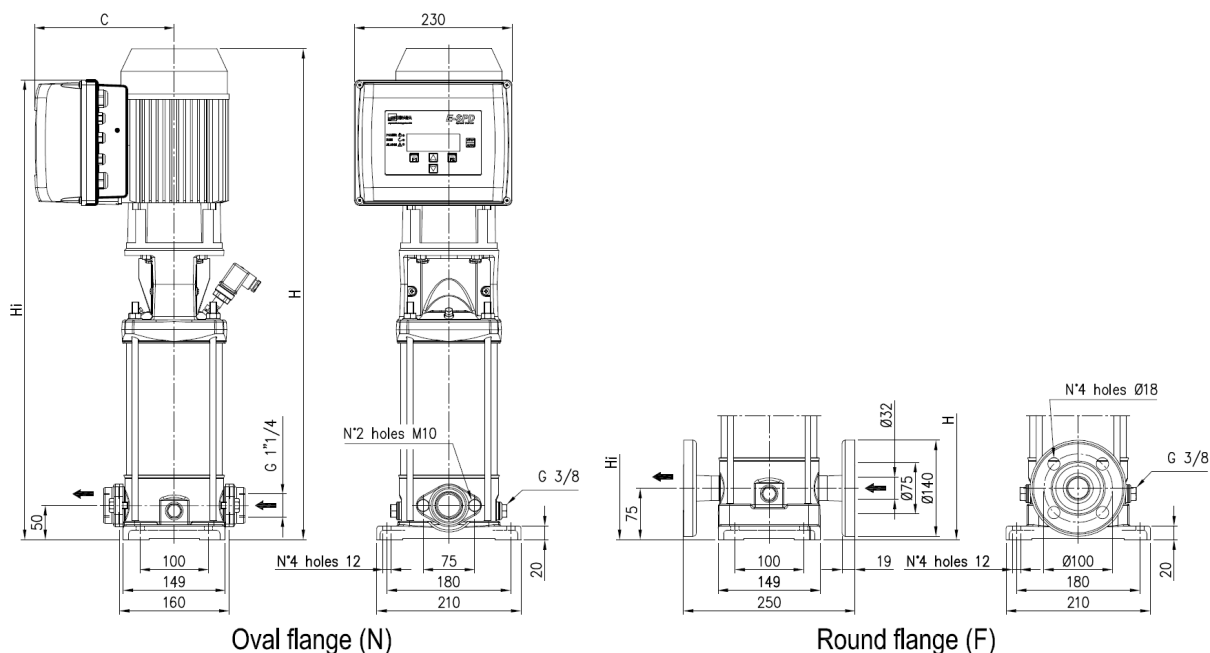

Pump with Inverter	Dimensions [mm]							
	kW	C	Oval flange (N)			Round flange (F)		
			H	Hi	Weight [kg]	H	Hi	Weight [kg]
EVMSG-K5 4/0.75 T(.)	0.75	191	563	558	25.7	588	583	30.2
EVMSG-K5 5/1.1 T(.)	1.1	191	602	586	27.7	627	611	32.2
EVMSG-K5 6/1.5 T(.)	1.5	203	687	642	31.7	712	667	36.3
EVMSG-K5 7/1.5 T(.)	1.5	203	715	670	32.2	740	695	36.7
EVMSG-K5 8/2.2 T(.)	2.2	203	743	698	34.3	768	723	38.8
EVMSG-K5 9/2.2 T(.)	2.2	203	771	726	34.8	796	751	39.3
EVMSG-K5 10/2.2 T(.)	2.2	203	799	754	35.3	824	779	39.8
EVMSG-K5 11/2.2 T(.)	2.2	203	827	782	36.1	852	807	40.6
EVMSG-K5 12/3.0 TT	3.0	210	916	820	44.3	941	845	48.8
EVMSG-K5 13/3.0 TT	3.0	210	944	848	44.9	969	873	49.4
EVMSG-K5 14/3.0 TT	3.0	210	972	876	45.5	997	901	50
EVMSG-K5 15/3.0 TT	3.0	210	1000	904	46.5	1025	929	51
EVMS(.)-K5 17/4.0 TT	4.0	225	1078	959	53.7	1103	984	58.2
EVMS(.)-K5 19/4.0 TT	4.0	225	-	-	-	1159	1040	59.3
EVMS(.)-K5 20/4.0 TT	4.0	225	-	-	-	1187	1068	61.5

- : not available model

### EVMS(L)-K10

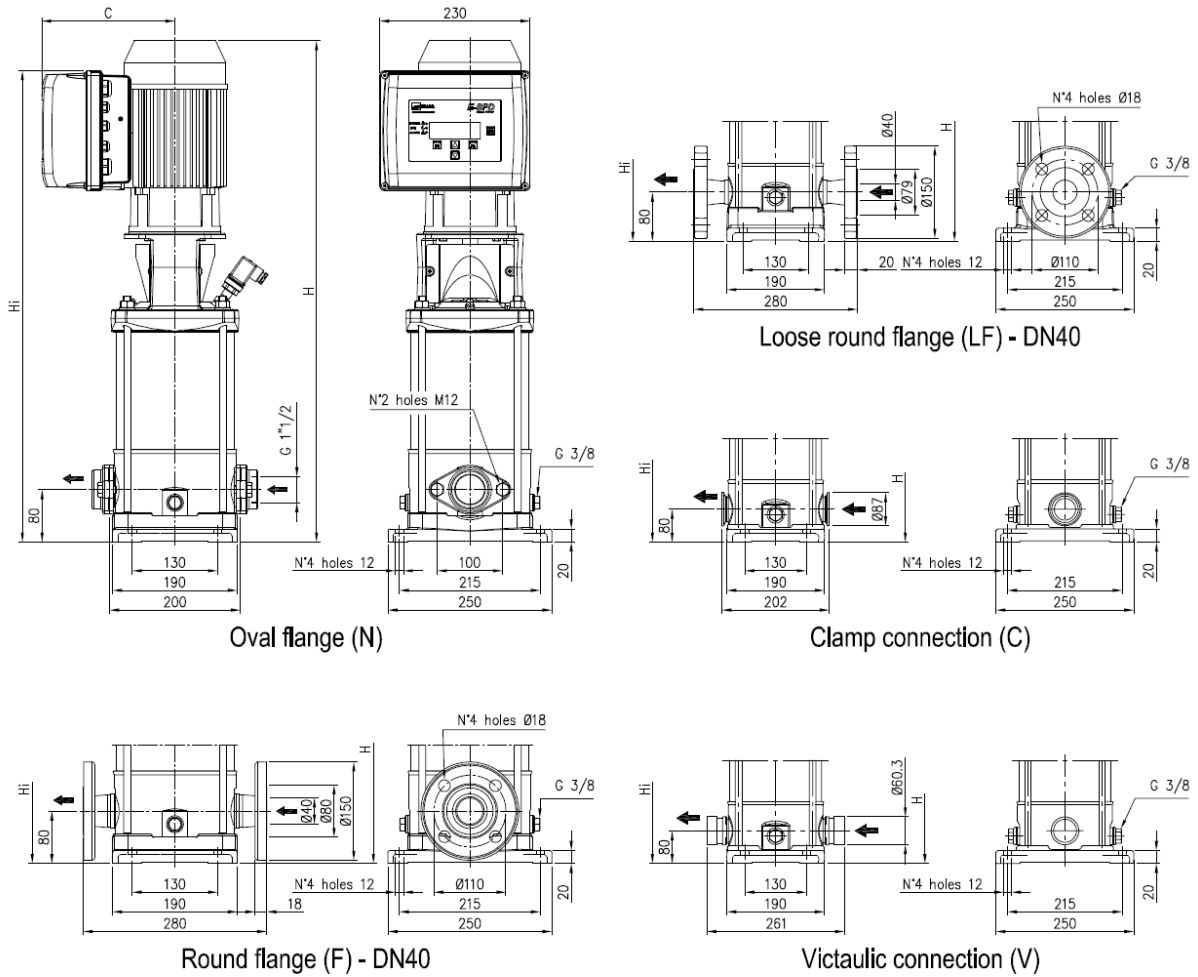

Pump with Inverter	Dimensions [mm]									
	kW	C	H	Oval flange (N)			Round flange (F)			
				Hi	Weight EVMS(L)-K [kg]	Weight EVMSG-K [kg]	H	Hi	Weight EVMS(L)-K [kg]	Weight EVMSG-K [kg]
EVMS(.)-K10 2/0.75 TT (MT)	0.75	191	576	571	28.8	32.8	576	571	28.7	35.5
EVMS(.)-K10 3/1.5 TT (MT)	1.5	203	674	629	34.7	38.7	674	629	34.7	41.5
EVMS(.)-K10 4/2.2 TT (MT)	2.2	203	704	659	37	41	704	659	37	43.7
EVMS(.)-K10 5/2.2 TT (MT)	2.2	203	734	689	37.9	41.9	734	689	37.8	44.6
EVMS(.)-K10 6/2.2 TT (MT)	2.2	203	764	719	38.7	42.7	764	719	38.7	45.4
EVMS(.)-K10 7/3.0 TT	3.0	210	855	759	46.7	50.7	855	759	46.6	53.4
EVMS(.)-K10 8/3.0 TT	3.0	210	885	789	47.5	51.5	885	789	47.5	54.2
EVMS(.)-K10 9/4.0 TT	4.0	225	937	818	54.9	58.9	937	818	54.8	61.6
EVMS(.)-K10 10/4.0 TT	4.0	225	967	848	55.7	59.7	967	848	55.7	62.4
EVMS(.)-K10 11/4.0 TT	4.0	225	997	878	57.3	61.3	997	878	57.3	64.1

773

### EVMSG-K10

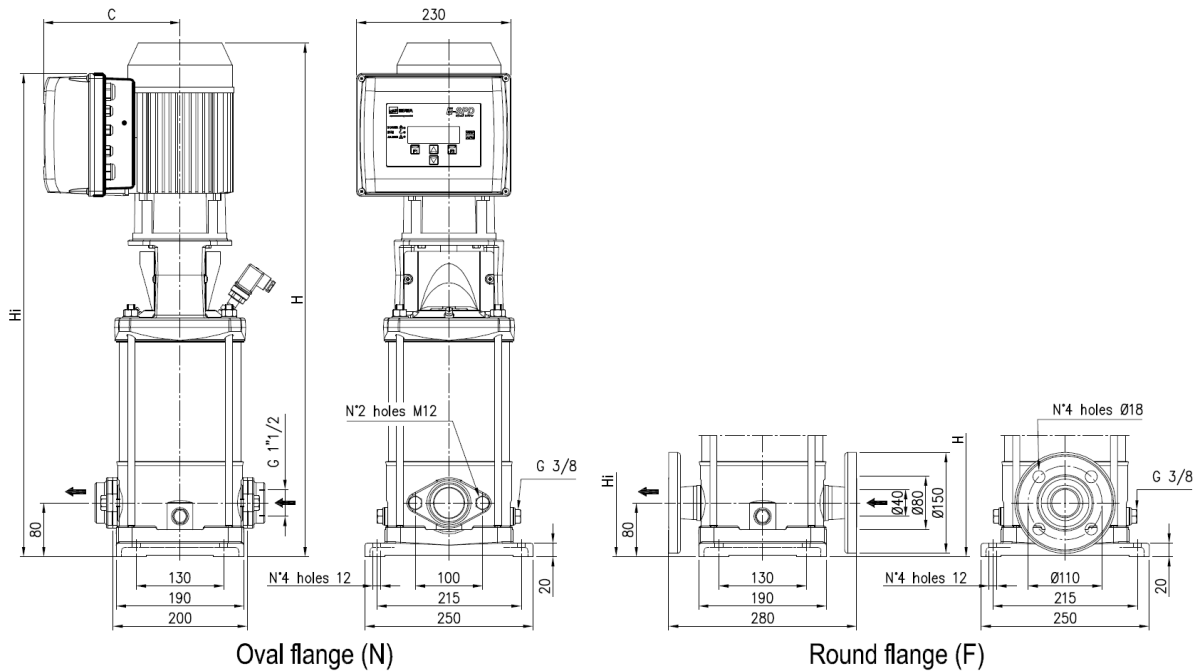

Pump with Inverter	Dimensions [mm]							
	kW	C	Oval flange (N)			Round flange (F)		
			H	Hi	Weight [kg]	H	Hi	Weight [kg]
EVMSG-K10 2/0.75 T(.)	0.75	191	576	571	32.8	576	571	35.5
EVMSG-K10 3/1.5 T(.)	1.5	203	674	629	38.7	674	629	41.5
EVMSG-K10 4/2.2 T(.)	2.2	203	704	659	41	704	659	43.7
EVMSG-K10 5/2.2 T(.)	2.2	203	734	689	41.9	734	689	44.6
EVMSG-K10 6/2.2 T(.)	2.2	203	764	719	42.7	764	719	45.4
EVMSG-K10 7/3.0 TT	3.0	210	855	759	50.7	855	759	53.4
EVMSG-K10 8/3.0 TT	3.0	210	885	789	51.5	885	789	54.2
EVMSG-K10 9/4.0 TT	4.0	225	937	818	58.9	937	818	61.6
EVMSG-K10 10/4.0 TT	4.0	225	967	848	59.7	967	848	62.4
EVMSG-K10 11/4.0 TT	4.0	225	997	878	61.3	997	878	64.1

### EVMS(L)-K15

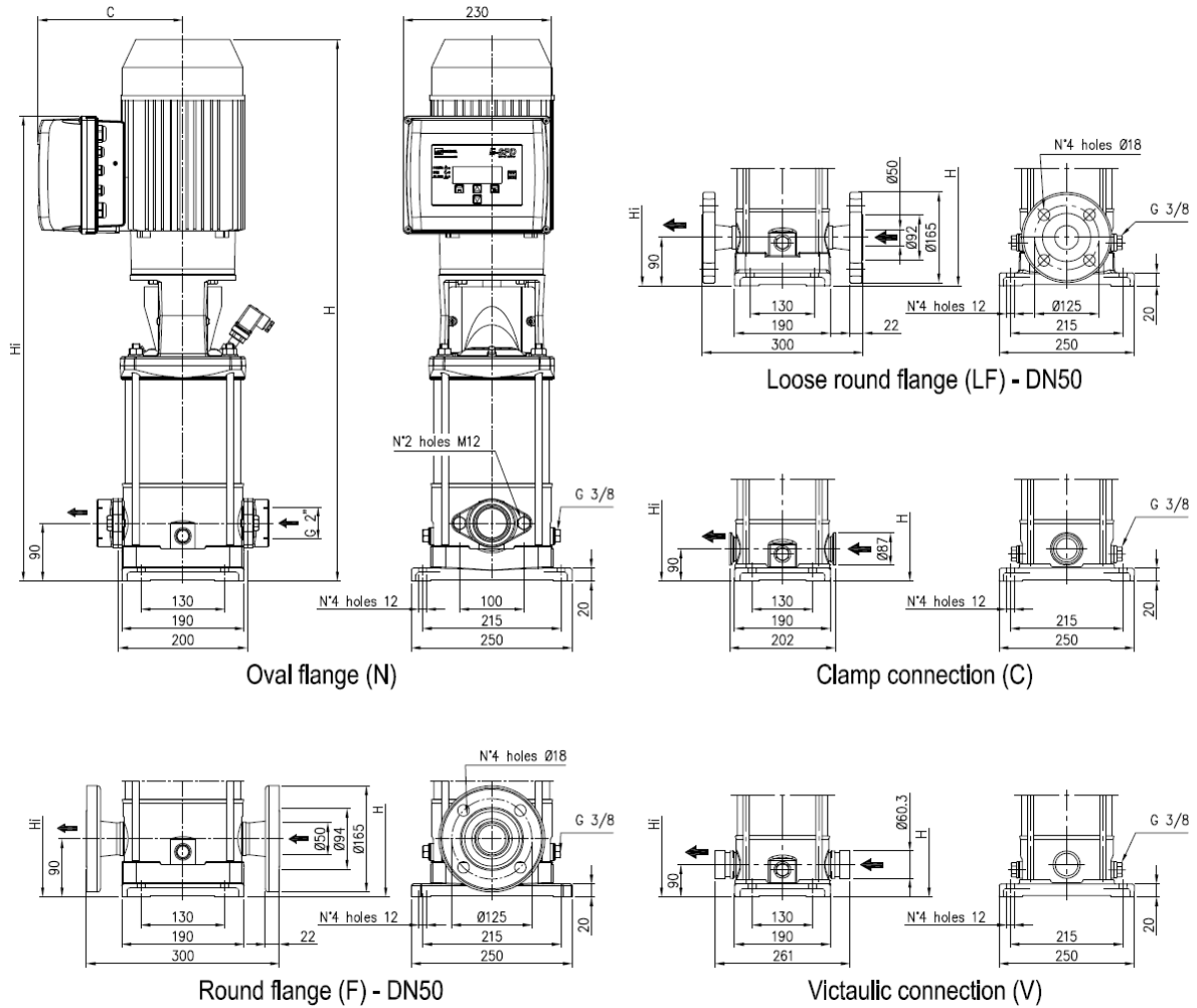

DIMENSION AND WEIGHT

Pump with Inverter	kW	C	Dimensions [mm]								
			Oval flange (N)			Victaulic® connection (V) Clamp connection (C)			Loose Round flange (LF) Round flange (F)		
			H	Hi	Weight [kg]	H	Hi	Weight [kg]	H	Hi	Weight [kg]
EVMS(L)-K15 1/1.1 (.)T	1.1	191	621	605	30.7	621	605	29.6	621	605	31.5
EVMS(L)-K15 2/2.2 (.)T	2.2	203	678	632	36	678	632	34.9	678	632	36.8
EVMS(L)-K15 3/3.0 TT	3.0	210	779	682	44.3	779	682	43.2	779	682	45.1
EVMS(L)-K15 4/4.0 TT	4.0	225	841	722	52.0	841	722	51.0	841	722	52.8

775

### EVMSG-K15

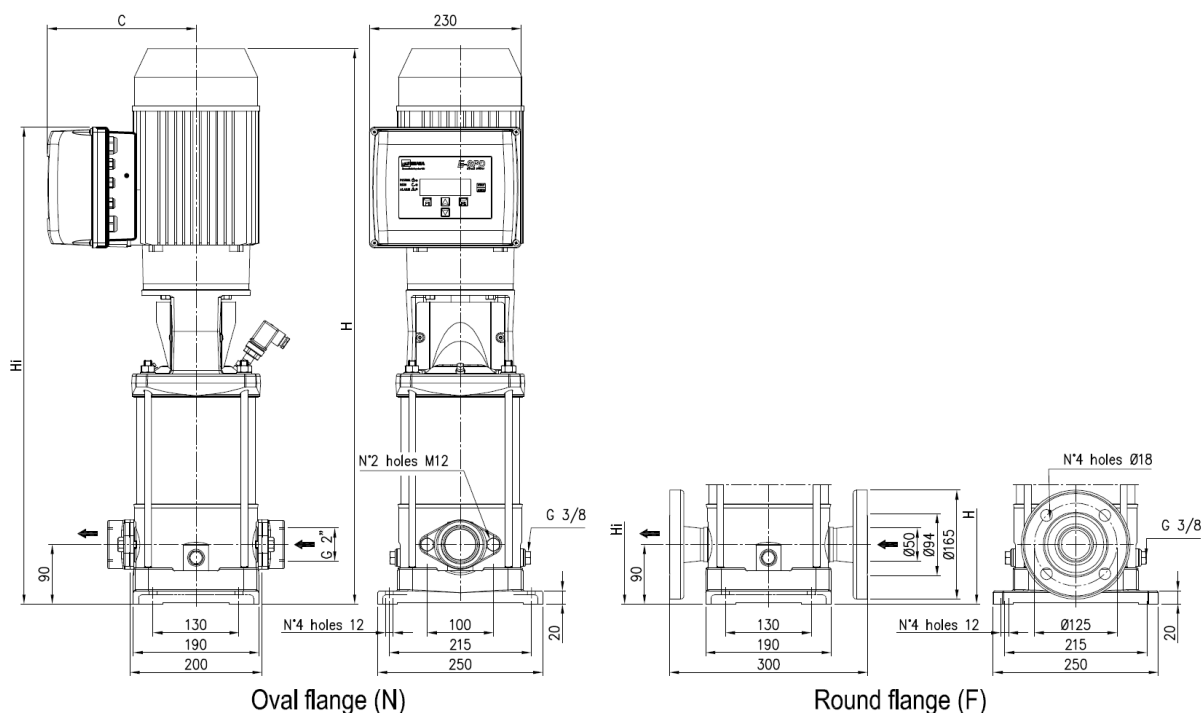

Pump with Inverter	kW	C	Dimensions [mm]					
			Oval flange (N)			Round flange (F)		
			H	Hi	Weight [kg]	H	Hi	Weight [kg]
EVMSG-K15 1/1.1 (.)T	1.1	191	621	605	35.1	621	605	39.6
EVMSG-K15 2/2.2 (.)T	2.2	203	678	632	40.3	678	632	44.9
EVMSG-K15 3/3.0 TT	3.0	210	779	682	48.7	779	682	53.2
EVMSG-K15 4/4.0 TT	4.0	225	841	722	56.4	841	722	61.0

### EVMS(L)-K20

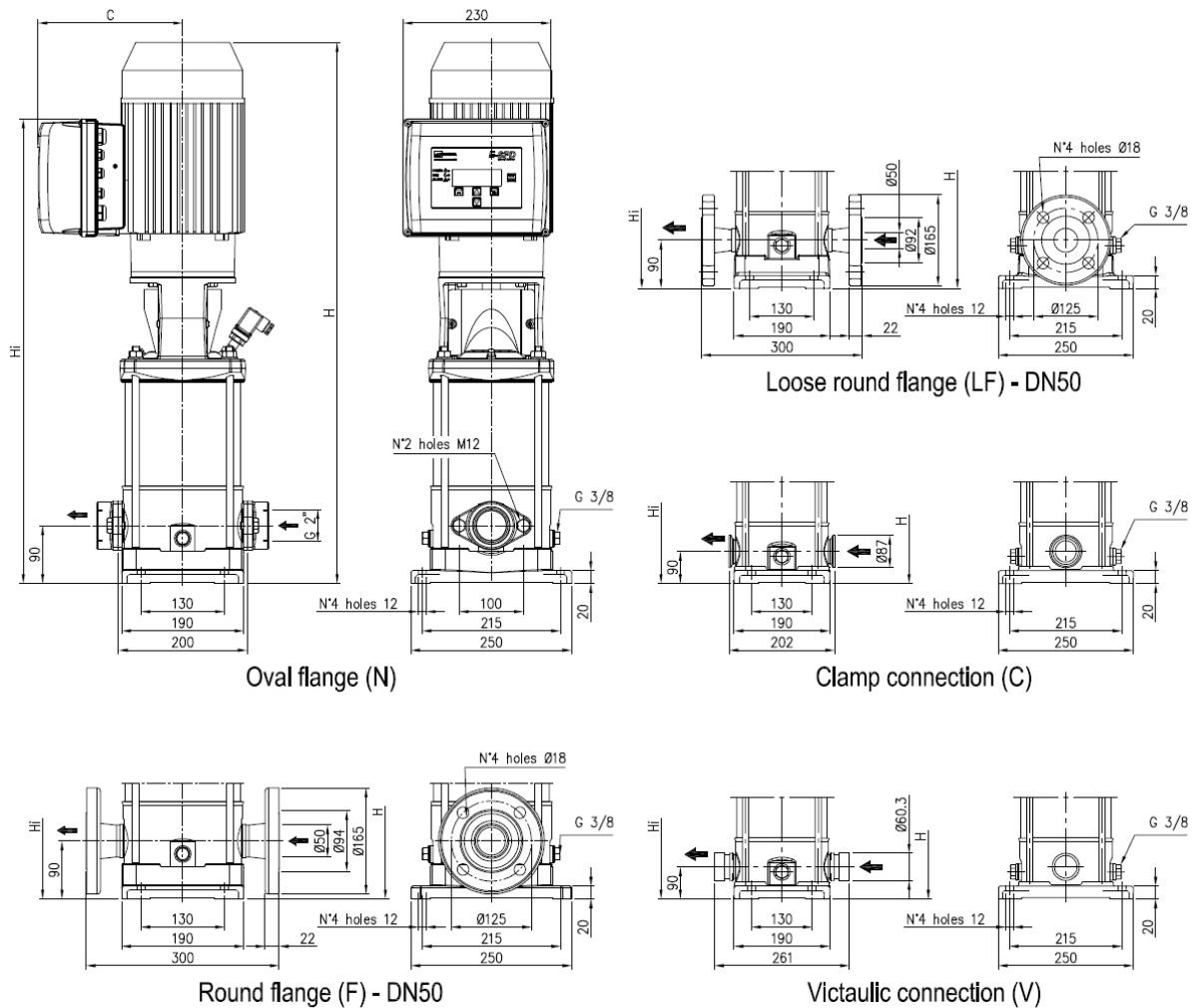

Pump with Inverter	kW	C	Dimensions [mm]								
			Oval flange (N)			Victaulic® connection (V) Clamp connection (C)			Loose Round flange (LF) Round flange (F)		
			H	Hi	Weight [kg]	H	Hi	Weight [kg]	H	Hi	Weight [kg]
EVMS(L)-K20 1/1.5 (.)T	1.5	203	678	632	34.4	678	632	33.3	678	632	36.2
EVMS(L)-K20 2/3.0 TT	3.0	210	739	642	43.0	739	642	41.9	739	642	43.8
EVMS(L)-K20 3/4.0 TT	4.0	225	801	682	51.0	801	682	49.9	801	682	51.8

### EVMSG-K20

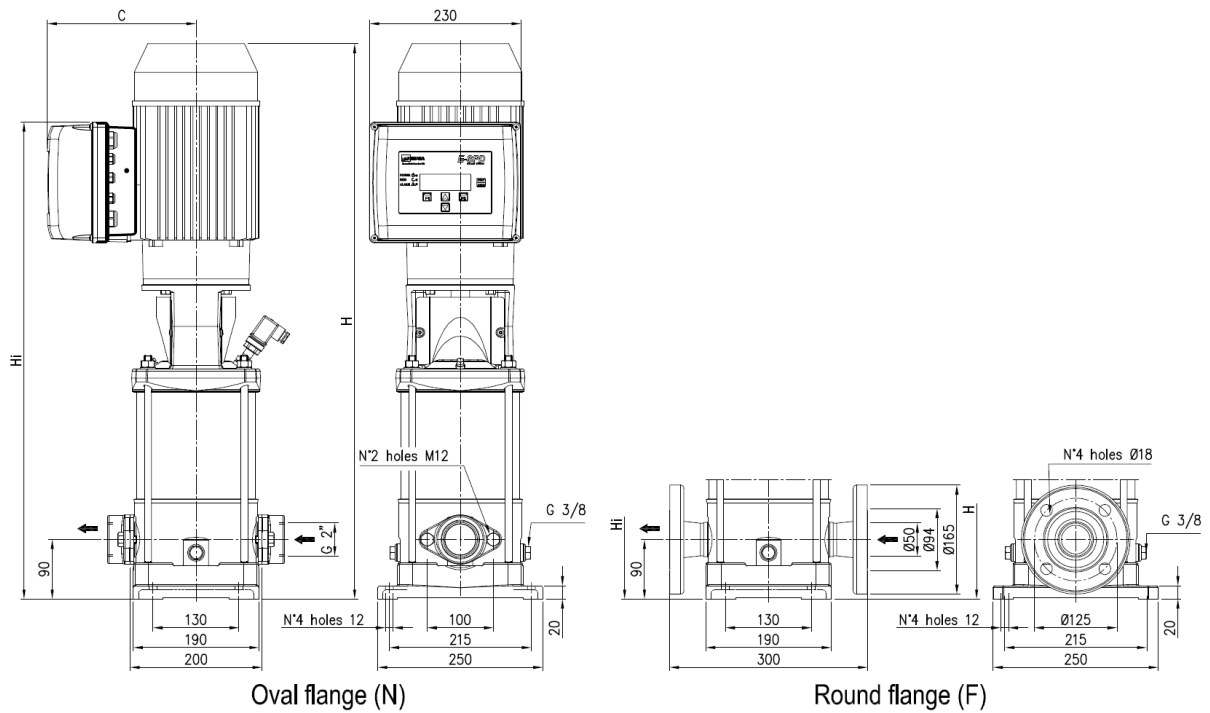

Pump with Inverter	Dimensions [mm]							
	kW	C	Oval flange (N)			Round flange (F)		
			H	Hi	Weight [kg]	H	Hi	Weight [kg]
EVMSG-K20 1/1.5 (.)T	1.5	203	678	632	38.8	678	632	43.4
EVMSG-K20 2/3.0 TT	3.0	210	739	642	47.4	739	642	52.0
EVMSG-K20 3/4.0 TT	4.0	225	801	682	55.3	801	682	60.0



### PACKING

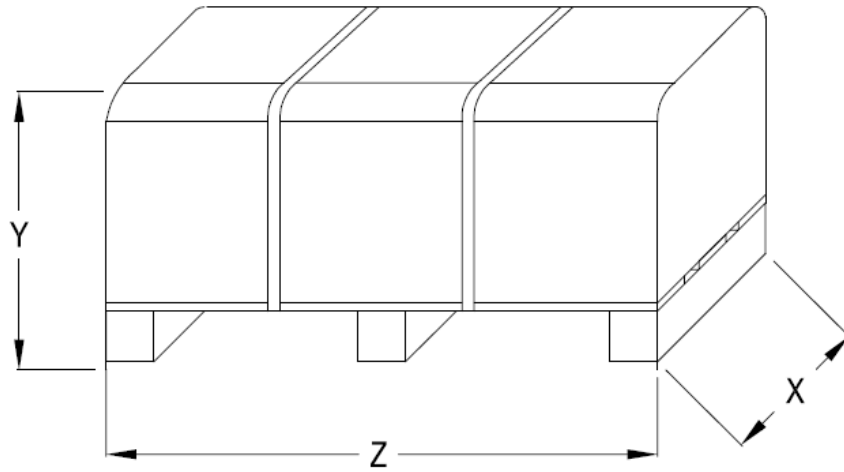

### EVMS(.)-K 1-3-5

Pump with inverter model	Overall dimensions packing			EVMS-K+packing Weight [kg]	EVMSG-K+packing Weight [kg]
	X	Y	Z		
EVMS(.)-K1 14/0.75	400	542	1000	45.5	52.5
EVMS(.)-K1 16/0.75	400	542	1000	46.5	53.5
EVMS(.)-K1 18/1.1	400	542	1200	49.1	56.1
EVMS(.)-K1 20/1.1	400	542	1200	50.1	57.1
EVMS(.)-K1 22/1.1	400	542	1200	53	60
EVMS(.)-K1 24/1.1	400	542	1200	54	61
EVMS(.)-K1 26/1.1	400	542	1200	55	62
EVMS(.)-K1 27/1.5	500	542	1350	58.9	65.9
EVMS(.)-K1 29/1.5	500	542	1350	65.6	72.6
EVMS(.)-K1 32/1.5	500	542	1350	66.9	73.9
EVMS(.)-K1 34/1.5	500	547	1540	67.8	74.8
EVMS(.)-K1 37/2.2	500	547	1540	87.5	94.5
EVMS(.)-K1 39/2.2	500	547	1540	88.5	95.5
EVMS(.)-K3 7/0.75	400	542	800	33.1	38.3
EVMS(.)-K3 8/0.75	400	542	800	33.6	38.8
EVMS(.)-K3 9/1.1	400	542	800	35.5	40.7
EVMS(.)-K3 10/1.1	400	542	800	36	41.2
EVMS(.)-K3 11/1.1	400	542	1000	36.4	41.6
EVMS(.)-K3 12/1.1	400	542	1000	46	51.2
EVMS(.)-K3 13/1.5	400	542	1000	50.2	55.4
EVMS(.)-K3 14/1.5	400	542	1000	50.6	55.8
EVMS(.)-K3 15/1.5	400	542	1000	51.1	56.3
EVMS(.)-K3 16/1.5	400	542	1000	52.1	57.3
EVMS(.)-K3 17/2.2	400	542	1200	54.1	59.3
EVMS(.)-K3 19/2.2	400	542	1200	56.8	62
EVMS(.)-K3 21/2.2	400	542	1200	57.7	62.9
EVMS(.)-K3 23/2.2	400	542	1200	58.7	63.9
EVMS(.)-K3 24/2.2	400	542	1200	59.1	64.3
EVMS(.)-K3 25/3.0	500	542	1350	72.4	77.6
EVMS(.)-K3 27/3.0	500	542	1350	73.4	78.6
EVMS(.)-K3 29/3.0	500	542	1350	74.3	79.6
EVMS(.)-K3 31/3.0	500	547	1540	75.3	80.5
EVMS(.)-K3 33/3.0	500	547	1540	92.9	98.1
EVMS(.)-K5 4/0.75	400	542	800	32.5	39
EVMS(.)-K5 5/1.1	400	542	800	34.5	41
EVMS(.)-K5 6/1.5	400	542	1000	47.8	54.2
EVMS(.)-K5 7/1.5	400	542	1000	48.2	54.6
EVMS(.)-K5 8/2.2	400	542	1000	50.2	56.7
EVMS(.)-K5 9/2.2	400	542	1000	50.8	57.2
EVMS(.)-K5 10/2.2	400	542	1000	51.2	57.7
EVMS(.)-K5 11/2.2	400	542	1000	52.1	58.5
EVMS(.)-K5 12/3.0	400	542	1200	62	68.4
EVMS(.)-K5 13/3.0	400	542	1200	62.6	69
EVMS(.)-K5 14/3.0	400	542	1200	70.3	69.6
EVMS(.)-K5 15/3.0	400	542	1200	64.2	70.6
EVMS(.)-K5 17/4.0	500	542	1350	71.4	77.8
EVMS(.)-K5 19/4.0	500	542	1350	72.5	78.9
EVMS(.)-K5 20/4.0	500	542	1350	80.4	86.8

### EVMS(.)-K 10-15-20

Pump with inverter model	Overall dimensions packing			EVMS-K+packing Weight [kg]	EVMSG-K+packing Weight [kg]
	X	Y	Z		
EVMS(.)-K10 2/0.75	400	542	800	37.5	44.3
EVMS(.)-K10 3/1.5	400	542	800	43.5	50.3
EVMS(.)-K10 4/2.2	400	542	1000	45.8	52.5
EVMS(.)-K10 5/2.2	400	542	1000	55.7	62.5
EVMS(.)-K10 6/2.2	400	542	1000	56.6	63.3
EVMS(.)-K10 7/3.0	500	612	1000	64.5	71.3
EVMS(.)-K10 8/3.0	500	612	1000	65.4	72.1
EVMS(.)-K10 9/4.0	500	612	1200	74.4	81.2
EVMS(.)-K10 10/4.0	500	612	1200	75.3	82
EVMS(.)-K10 11/4.0	500	612	1200	76.9	83.7
EVMS(.)-K15 1/1.1	400	542	800	40.3	48.4
EVMS(.)-K15 2/2.2	400	542	800	45.6	53.7
EVMS(.)-K15 3/3.0	500	612	1000	63	71.1
EVMS(.)-K15 4/4.0	500	612	1000	70.7	78.8
EVMS(.)-K20 1/1.5	400	542	800	40.3	48.4
EVMS(.)-K20 2/3.0	500	612	1000	54.7	62.8
EVMS(.)-K20 3/4.0	500	612	1000	63	71.1

### CONTROL PANEL VARIABLE SPEED

#### E-SPD SPECIFICATION

In-line electronic device for controlling electropumps, employing inverter technology. Starts and stops the pump and modulates the speed of the motor in relation to the water demand on the system, to maintain the operating pressure setting. Provides excellent comfort for the end user, significant energy savings and increased service life, the typical advantages of inverter controlled systems. E-SPD is an inverter that could be installed on the terminal box. It can be adapted on horizontal and vertical pumps. E-SPD can protect the system against overpressure, overcurrent, voltage fluctuation, dry run and water leak. The connection for this mode is made by communication line ON/OFF.

E-SPD			
Power	Version	MT	TT
	Power Voltage	Single-phase 230 V	Three-phase 400 V
	Output Voltage (pump)	Three-phase 230 V	Three-phase 400 V
	Output frequency	50 ÷ 60Hz	
	Maximum pump power	2.2 kW	4 kW
	Max I in	20 A	12 A
	Max I out	11 A	11 A
Others	Pressure setpoint	0.5 ÷ 25 bar	
	Protection degree	IP 55	
	Ambient Temperature	-10 ÷ 40°C	
	Pressurisation units	2-3 pumps	
	Weight	2,7 Kg	
	Protection	Dry-running	
		Over/under voltage	
		Short-circuit	
		Overload	
Overtemperature			
Low pressure			
Pressure sensor fault			
Directives	2014/35/EU (LVD), 2014/30/EU (EMC), 2011/65/EU (RoHS II)		

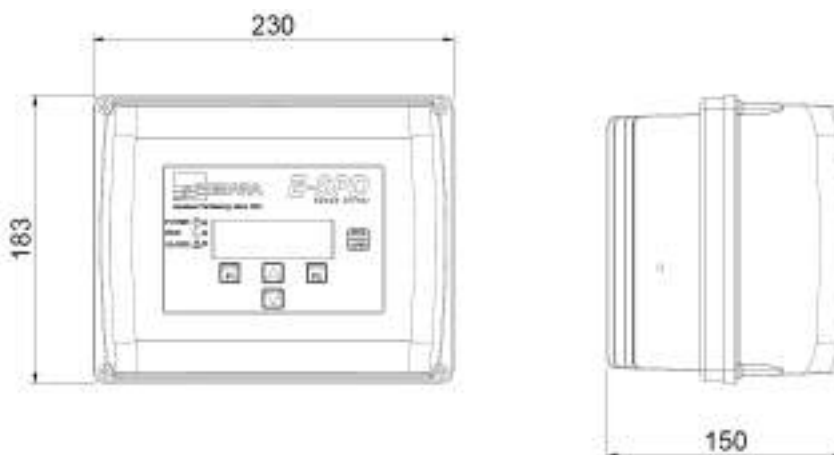

801



**EBARA Pumps Europe S.p.A.**

Via Torri di Confine 2/1 int. C  
36053 Gambellara (Vicenza), Italy  
Phone +39 0444 706811  
Fax +39 0444 405811  
ebara\_pumps@ebaraeurope.com  
www.ebaraeurope.com

**EBARA Corporation**

11-1, Haneda Asahi-cho, Ota-ku,  
Tokyo 144-8510  
Japan  
Tel +81 3 6275 7598  
Fax +81 3 5736 3193  
www.ebara.com

