



Data sheet

Hydraulic data

Maximum operating pressure p	3.8 bar
Discharge port	Storz B
Free ball passage of the hydraulics	10 mm
Impeller type	Open multi-channel impeller
Max. immersion depth	20 m
Max. delivery head H_{\max}	34.7 m
Max. volume flow Q_{\max}	81.0 m ³ /h
Min. fluid temperature T_{\min}	3 °C
Max. fluid temperature T_{\max}	40 °C
Min. ambient temperature T_{\min}	3 °C
Max. ambient temperature T_{\max}	40 °C

Motor data

Mains connection	3~400 V, 50 Hz
Voltage tolerance	±10 %
Rated power P_2	6 kW
Power consumption $P_{1 \max}$	6.90 kW
Rated current I_N	11.6 A
Starting current I	90 A
Operating mode (immersed)	S1
Operating mode (non-immersed)	S1
Rated speed n	2910 1/min
Power factor $\cos \varphi_{100}$	0.86
Activation type	Direct On Line (DOL)
Number of poles	2
Max. switching frequency t	20 1/h
Insulation class	H
Protection class motor	IP68

Cable

Connection cable length L	23 m
Cable type	H07RN-F
Cable cross-section	7G1,5 mm ²
Type of connection cable	Non-detachable

Equipment/function

Mains plug	CEE 32A, 3P+N+PE, 6h
Float switch	yes
Explosion protection type	-
Motor protection	Bimetall
Motor, leakage detection	no
Sealing chamber, leakage detection	no
Leakage chamber, leakage detection	no

Materials

Pump housing	Aluminium
Impeller	Stainless steel
Shaft	Stainless steel
Sealing on pump side	Silicon carbide
Sealing on motor side	NBR
Gasket material	NBR
Motor housing	Aluminium

Installation dimensions

Inlet connection	-
Outlet connection	Storz B

Pump curves

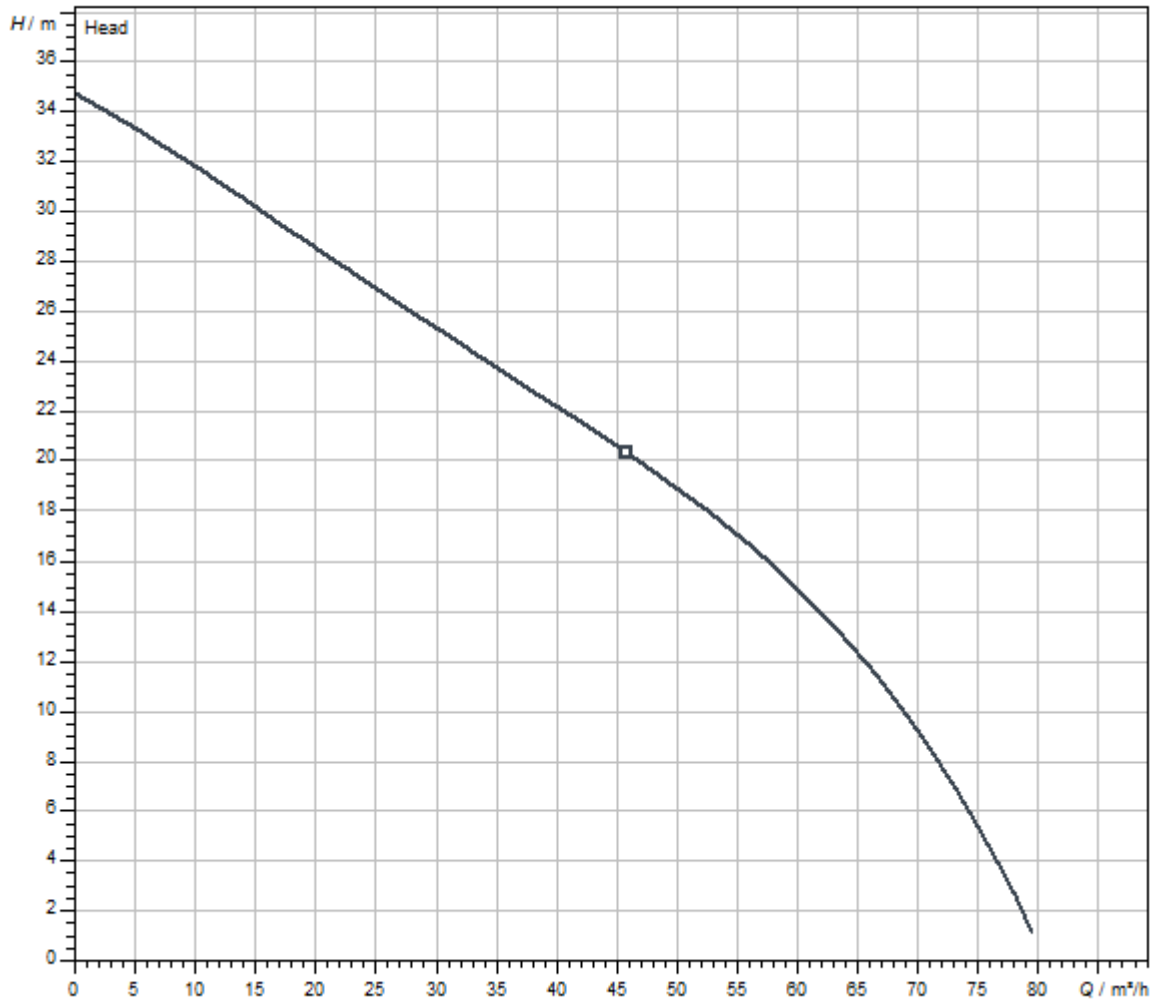

Fluid media	Water 100 %
Fluid temperature T	20.00 °C
speed at duty point $n_{hydr. @ OP}$	2,900 1/min
Impeller diameter $d_{imp.}$	172 mm

Dimensions and dimensions drawings

Padus PRO M08

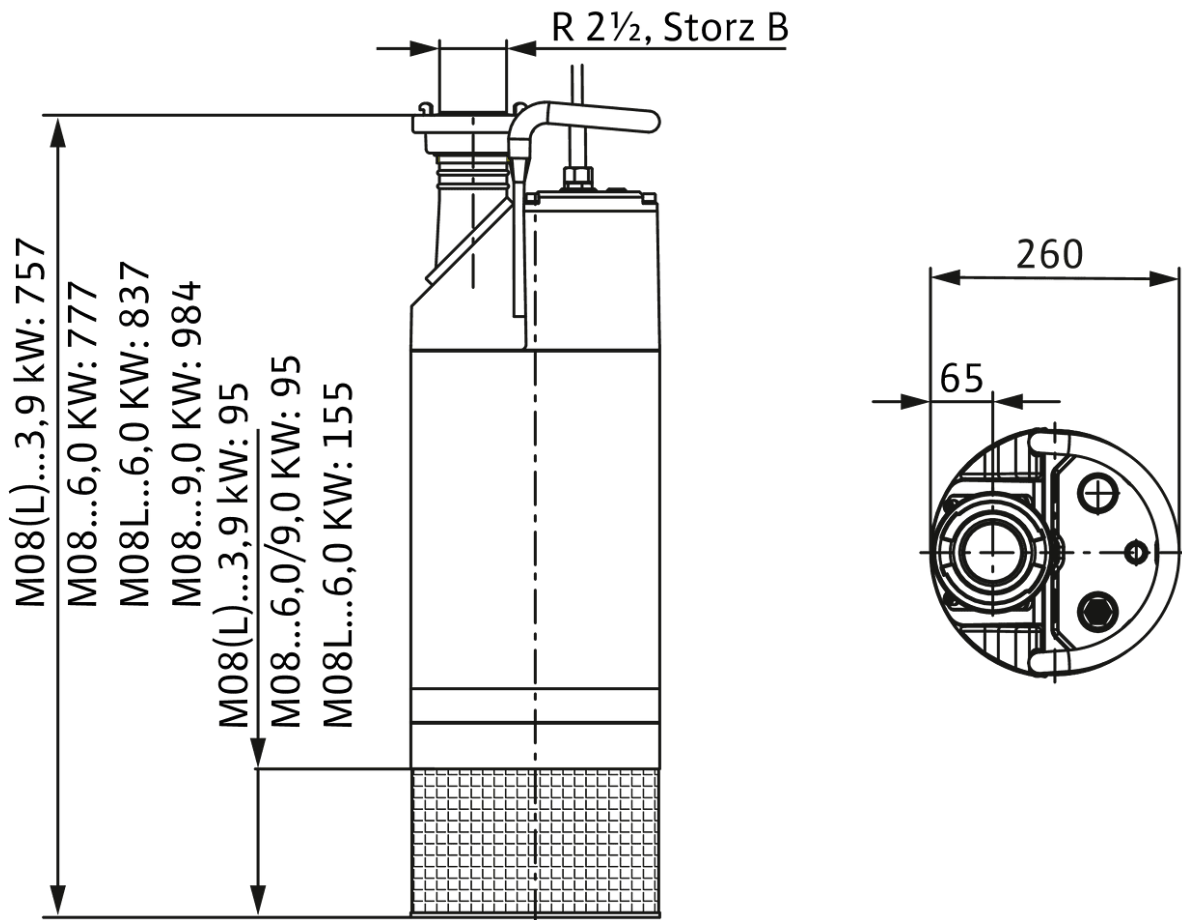

Tender text

Fully submersible drainage pump for vertical wet well installation for pumping contaminated and sandy water. Hydraulics housing made of rubberised aluminium, impeller of duplex chrome steel and motor housing of aluminium in the cooling shroud made of stainless steel. Pressure connection with vertical or horizontal pressure outlet and Storz coupling. Surface-cooled IE3 motor in

three-phase current version with thermal motor monitoring and sealing chamber. Detachable connection cable with float switch and CEE motor protection plug. The seal employs two bidirectional mechanical seals. The unit can be used without limits in slurping operation.

Operating Data

Product data

Impeller type	Open multi-channel impeller
Free ball passage of the hydraulics	10 mm
Maximum operating pressure P_N	4 bar
Max. immersion depth	20 m
Fluid temperature T	3 °C
Max. fluid temperature T_{max}	40 °C

Motor data

Mains connection	3~400 V, 50 Hz
Voltage tolerance	±10 %
Power factor $\cos \varphi_{100}$	0.86
Rated power P_2	6 kW
Power consumption $P_{1\ max}$	6.90 kW
Rated current I_N	11.6 A
Starting current I	90 A
Activation type	Direct On Line (DOL)
Rated speed n	2910 1/min
Max. switching frequency t	20 1/h
Insulation class	H
Protection class	IP68
Operating mode (immersed)	S1
Operating mode (non-immersed)	S1

Cable

Connection cable length L	23 m
Cable type	H07RN-F
Cable cross-section	7G1,5 mm ²
Mains plug	CEE 32A, 3P+N+PE, 6h
Type of connection cable	Non-detachable

Equipment/function

Float switch	yes
Explosion protection type	-
Motor protection	Bimetall

Materials

Pump housing	Aluminium
Impeller	Stainless steel
Shaft	Stainless steel
Sealing on pump side	QQPGG
Sealing on motor side	BXPFF
Gasket material	NBR
Motor housing	Aluminium

Installation dimensions

Pipe connection on the suction side D_Ns	-
Pipe connection on the discharge side D_Nd	Storz B

Ordering information

Brand	Wilo
Product description	Padus PRO M08/T060-540/A
Net weight, approx. m	69 kg
Article number	6083439 

Installation type

Portable wet well installation



Installation example

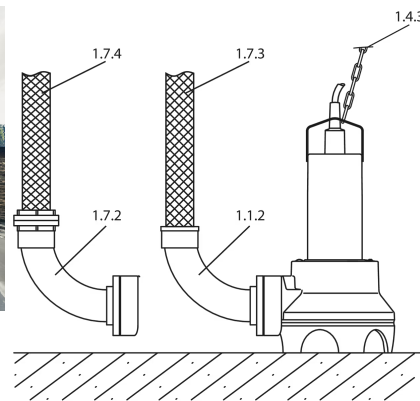

Installation drawing

The pump is equipped with a pump foot (integrated in the pump housing or separately as an accessory). With this pump foot, the pump can be easily and flexibly installed in any operating space. Hoses are used as discharge pipes. Connection is with a hose nipple or Storz coupling. For a level-dependent operation, it is recommended to use a pump with a float switch.

Plastic spiral hose with coupling 1.7.4

Plastic spiral hose 10 m, with Storz B	6035187
Plastic spiral hose 20 m, with Storz B	6022274
Plastic spiral hose 5 m, with Storz B	6022272

Synthetic fibre hose with coupling 1.7.4

Synthetic fibre pressure hose 10 m, with Storz B	6003051
Synthetic fibre pressure hose 20 m, with Storz B	6003050
Synthetic fibre pressure hose 5 m, with Storz B	6003052

Coupling key 1.7.7

Coupling key for Storz A, B, C	6022280
--------------------------------	---------

Mechanical accessories

Hoses / hose joints

Coupling key

Coupling key for Storz A, B, C	6022280
Coupling key for Storz F	6022281

Plastic spiral hose with coupling

Plastic spiral hose 5 m, with Storz C	6022269
Plastic spiral hose 10 m, with Storz C	6022270
Plastic spiral hose 20 m, with Storz C	6022271
Plastic spiral hose 5 m, with Storz B	6022272
Plastic spiral hose 20 m, with Storz B	6022274
Plastic spiral hose 5 m, with Storz A	6022275
Plastic spiral hose 10 m, with Storz A	6022276
Plastic spiral hose 20 m, with Storz A	6022277
Plastic spiral hose 5 m, with Storz F	6022278
Plastic spiral hose 10 m, with Storz B	6035187
Plastic spiral hose 5 m, with Storz F	6044660

Synthetic fibre hose with coupling

Synthetic fibre pressure hose 20 m, with Storz B	6003050
Synthetic fibre pressure hose 10 m, with Storz B	6003051
Synthetic fibre pressure hose 5 m, with Storz B	6003052
Synthetic fibre pressure hose 20 m, with Storz F	6003647
Synthetic fibre pressure hose 10 m, with Storz F	6003648
Synthetic fibre pressure hose 20 m, with Storz C	6003649
Synthetic fibre pressure hose 10 m, with Storz C	6003650
Synthetic fibre pressure hose 5 m, with Storz C	6003651
Synthetic fibre pressure hose 5 m, with Storz A	6022391
Synthetic fibre pressure hose 10 m, with Storz A	6022392
Synthetic fibre pressure hose 20 m, with Storz A	6022393

Electrical accessories

Alarm signal

DrainAlarm

DrainAlarm	2545133
DrainAlarm FIRST	2550526

Cable

Connection cable

50 m connection cable H07RN-F 6G1,5	6087988
30 m connection cable H07RN-F 6G1	6087989
30 m connection cable H07RN-F 3G1	6087990
30 m connection cable H07RN-F 3G1	6087991
20 m connection cable H07RN-F 6G1	6087992

Services

With Wilo as your partner, you can not only be sure of choosing high-quality product solutions, but also of benefiting from a comprehensive, worry-free package of well thought-out services. We collaborate to develop a service concept tailored to your individual needs; with our expertise and personal consultancy, we make sure that the operation of your systems is as energy-efficient, reliable and economical as possible. All the while our competent Wilo service technicians are ready to assist you with fast, reliable and on-time support.

Recommended services

Commissioning Drainage pumps	2219491
Wilo-Live Assistant Service	2216415
Maintenance BASIC Drainage pumps	2219540
Maintenance COMFORT Drainage pumps	2219514
Maintenance PREMIUM Drainage pumps	2219567

More suitable services

Extended Warranty Drainage pumps	2219465
Supervision Drainage pumps	2219348
Installation Drainage pumps	2219383
System Optimisation Drainage pumps	2219278
Energy Solutions Drainage pumps	2219313
Repair Drainage pumps	2219632