



Data sheet

Hydraulic data

Maximum operating pressure P_N	10 bar
Head max H_{max}	8.1 m
Flow max Q_{max}	4.4 m ³ /h
Minimum suction head at 50 °C m	0.5 m
Minimum suction head at 95 °C m	3 m
Minimum suction head at 110 °C	10 m
Min. fluid temperature T_{min}	-10 °C
Max. fluid temperature T_{max}	110 °C
Max. fluid temperature at max. ambient temperature of +25 °C T_{max}	110 °C
Max. fluid temperature at max. ambient temperature of +40 °C T_{max}	95 °C
Min. ambient temperature T_{min}	-10 °C
Max. ambient temperature T_{max}	40 °C

Motor data

Energy efficiency index (EEI)	≤0.23
Mains connection	1~230 V ±10%, 50/60 Hz
Rated power P_2	58 W
Min. speed n_{min}	500 1/min
Max. speed n_{max}	4800 1/min
Power consumption $P_{1 min}$	3 W
Power consumption $P_{1 max}$	75 W
Emitted interference	EN 61000-6-3
Interference resistance	EN 61000-6-2
Electromagnetic compatibility	EN 61800-3
Threaded cable connection	1 x PG11
Insulation class	F
Protection class	IPX4D

Materials

Pump housing	Grey cast iron
Impeller	PP-GF40
Shaft	Stainless steel
Bearing	Carbon, metal-impregnated

Installation dimensions

Pipe connection on the discharge side DNd	G 1½
Pipe connection on the suction side DN_s	G 1½
Port-to-port length L_0	180 mm

Equipment/function

Function

Control mode	Δp -v for variable differential pressure
	Δp -c for constant differential pressure
	Dynamic Adapt plus
	Constant speed (n-const.)
Special features of the series	Night set back
	Mode for pressure-independent control valves (PICV)
	Key locking function
	Reset function for electricity meter
	Reset function to factory setting
Display	Setpoint
	Actual delivery head
	Actual volume flow
	Actual power consumption
	Energy consumption
	Actual speed
	Manually activated restart or pump venting function
	Warning messages in plain text (display status: yellow)
	Error messages in plain text (display: red)
	Control mode
	Active influences (e.g. STOP)
Pump venting function	Manual

Equipment

Approvals and labels	CE
	VDE
	EAC
	UKCA
	TR
	RCM
Display	Graphic colour display (2 inches)
Display information	Comfort Version: LCD display (large) for showing the head, flow volume, actual und cumulated current.
Pump control	Electronic-controlled pump
Quick electrical connection	Wilo Connector
Thermal insulation shell	Yes
Blocking-current proof motor	yes
Particle filter	yes
Key lock	yes
Operating elements	Green button and back button

Connectivity

Access via the Wilo-Assistant app	Via accessory Wilo-Smart Connect Module BT
Analogue signal as standard	0-10 V (via BMS Connect module accessories)
Digital input	Ext. OFF/Ext. MIN/ Ext. MAX (via BMS Connect module accessories)
Digital output	SSM/SBM (via BMS Connect module accessories)
wire data exchange and remote operation	Via accessories Wilo-Smart Connect Module BT

Pump curves

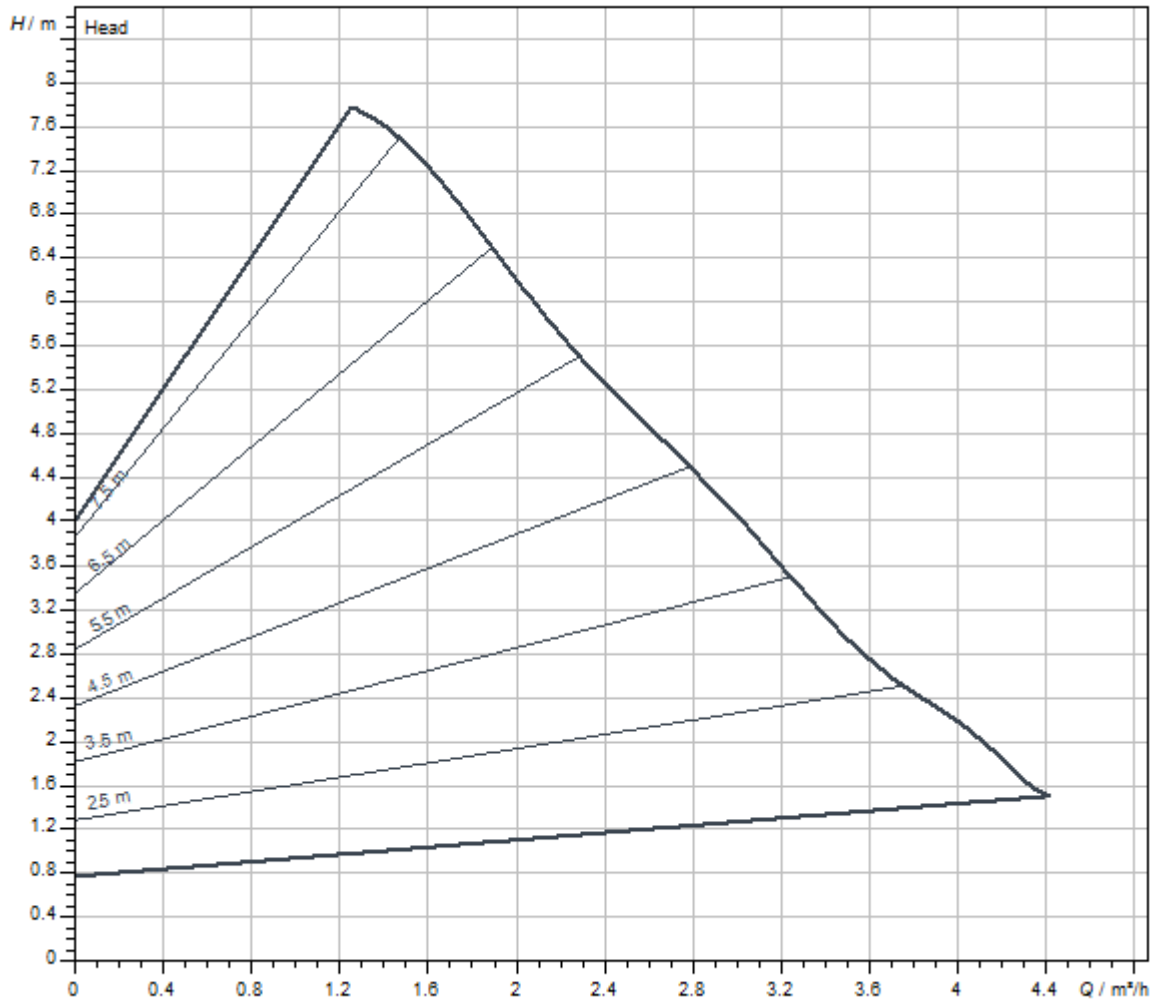

Fluid media	Water 100 %
Fluid temperature <i>T</i>	20.00 °C
speed at duty point <i>n hydr. @ OP</i>	4,650 1/min

Dimensions and dimensions drawings

Stratos PICO 25/0,5-8

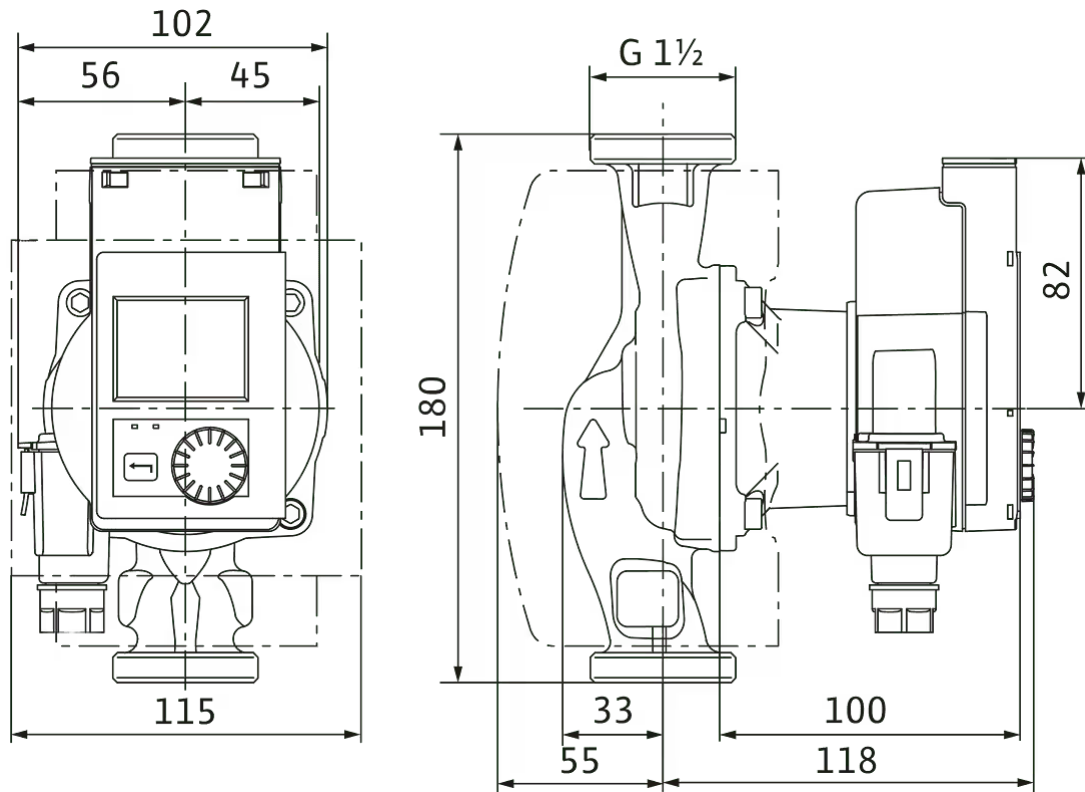

Wiring diagram

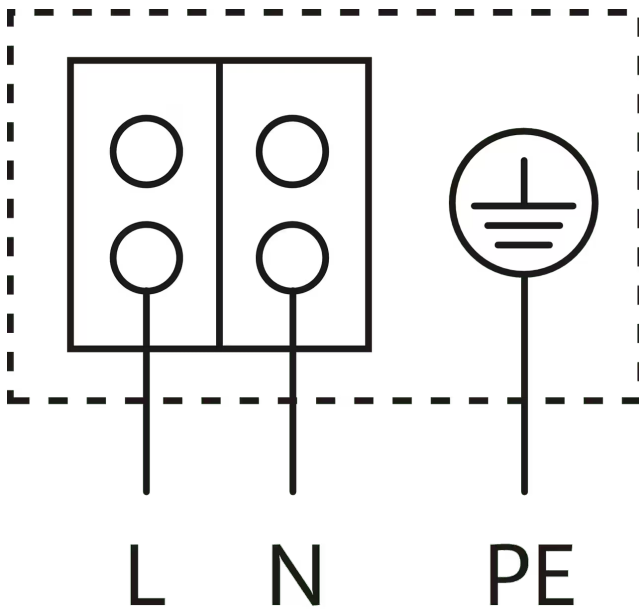

Blocking current-proof motor

Single-phase motor (EM) 2-pole - 1~230 V, 50 Hz

Ordering information

Product data

Brand	Wilo
Product description	Stratos PICO 25/0,5-8
Article number	4244397 
EAN number	4062679126104
Colour	Green
Minimum order quantity	1
Date of sales availability	2022-01-01

Packaging

Packaging type	Cardboard box
Packaging property	Sales packaging
Pieces per pallet	146
Number per layer	20

Dimension, weight

Length with packaging	194 mm
Length <i>L</i>	180 mm
Height with packaging	121 mm
Height <i>H</i>	114 mm
Width with packaging	213 mm
Width <i>W</i>	177 mm
Gross weight, approx. <i>m</i>	2.4 kg
Net weight, approx. <i>m</i>	2.1 kg

Tender text

WILO Stratos PICO, electronically controlled high efficiency pump

Glandless circulator with screwed connection, blocking-current proof synchronous motor using ECM technology (up to 90 % energy saving compared to an uncontrolled pump) and built-in electronic power control for continuous differential pressure control.

Can be used for all heating and air-conditioning applications (-10 °C to +110 °C).

Control mode can be selected in accordance with the radiator/underfloor heating application.

Control modes:

- > Permanent, automatic power adjustment to system requirements without setpoint specification **Wilo Dynamic Adapt plus** (factory setting)
- > Settings assistant for **number of radiators** or **underfloor heating area**
- > Variable differential pressure (**$\Delta p-v$**)
- > Constant differential pressure (**$\Delta p-c$**)
- > Constant speed (**$n\text{-const.}$**)

Functions:

- > Automatic night setback
- > Fault/warning message display including description and error code in plain text
- > Venting routine for automatic venting of the rotor chamber
- > Manual restart function for additional deblocking of the pump as required
- > Key lock
- > Function for resetting the electricity meter or for resetting the settings to the factory settings
- > Dry-running detection
- > Automatic deblocking function and integrated motor protection
- > Supports hydraulic balancing with the Wilo-Assistant app

Display:

- > Control mode
- > Setpoint
- > Volume flow
- > Delivery head
- > Speed
- > Power consumption
- > Electric consumption
- > Active influences (e.g. night setback, deaeration)

Version:

- > Graphic colour display with operation via one button manual operation level
- > Slot for Wilo communication modules as an interface for e.g. Bluetooth
- > Use the Wilo-Assistant app to read and set operating data and –among other things– set up a commissioning protocol through the Bluetooth interface (as an accessory)
- > Minimal consumption only 3 W
- > Equipped as standard with a thermal insulation shell
- > 5-year warranty
- > High efficiency, TÜV tested (the certificate can be seen at www.wilo.com/legal)

Optional accessories:

- > Wilo-Smart Connect module BT for Bluetooth connection to mobile devices via Wilo-Assistant app
- > The Wilo-Connect module BMS expands the interface for use in building management systems (BMS)

Operating Data

Min. fluid temperature T_{\min}	-10 °C
Max. fluid temperature T_{\max}	110 °C
Min. ambient temperature T_{\min}	-10 °C
Max. ambient temperature T_{\max}	40 °C
Maximum operating pressure PN	10 bar
Minimum suction head at 50 °C m	0.5 m
Minimum suction head at 95 °C m	3 m
Minimum suction head at 110 °C	10 m

Motor data

Energy efficiency index (EEI)	≤ 0.23
Emitted interference	EN 61000-6-3
Interference resistance	EN 61000-6-2
Mains connection	1~230 V, 50/60 Hz
Power consumption $P_{1 \max}$	75 W
Min. speed n_{\min}	500 1/min
Max. speed n_{\max}	4800 1/min
Protection class motor	IPX4D

Motor data

Threaded cable connection	1 x PG11
---------------------------	----------

Materials

Pump housing	Grey cast iron
Impeller	PP-GF40
Shaft	Stainless steel
Bearing	Carbon, metal-impregnated

Installation dimensions

Pipe connection on the suction side <i>DN_s</i>	G 1½
Pipe connection on the discharge side <i>DN_d</i>	G 1½
Port-to-port length <i>L₀</i>	180 mm

Ordering information

Brand	Wilo
Product description	Stratos PICO 25/0,5-8
Net weight, approx. <i>m</i>	2.1 kg
Article number	4244397 

Mechanical accessories

Pipe installation

Screwed connections/adapters

Screwed connection Rp 1 x G 1½, 72 Set	112047298
Screwed connection Rp 1 x G 1½, 1 Set	4092741
Adapter G 1½/G 2	4105914

Pipe installation, adapter fitting

Flanged rings RF

Flanged ring RF 7, PN6	110628790
Flanged ring RF 9, PN6	110679395
Flanged ring RF 13, PN6	110679498
Flanged ring RF 10, PN6	110851499

Threaded adapter R

Threaded adapter R 2, GG	110626790
Threaded adapter R 6, GG	110678493
Threaded adapter R 1, GG	110786891
Threaded adapter R 7, GG	110787094
Threaded adapter R 24, GG	110880596

Thermal insulation

Thermal insulation shell

Thermal insulation shell	4206066
--------------------------	---------

Electrical accessories

Pump control

Timer switch SK 601N

Switchgear SK 601N	2120443
--------------------	---------

Pump control/interface module

Connect module BMS

Wilo-Connect module BMS	4257834
-------------------------	---------

Wilo-Smart Connect module BT

Wilo-Smart Connect module BT	4239241
------------------------------	---------

Plug

Angle plug

Angle plug	4150229
------------	---------

Connector

Wilo-Connector	4200870
----------------	---------

Services

With Wilo as your partner, you can not only be sure of choosing high-quality product solutions, but also of benefiting from a comprehensive, worry-free package of well thought-out services. We collaborate to develop a service concept tailored to your individual needs; with our expertise and personal consultancy, we make sure that the operation of your systems is as energy-efficient, reliable and economical as possible. All the while our competent Wilo service technicians are ready to assist you with fast, reliable and on-time support.

Recommended services

Wilo-Live Assistant Service	2216415
System Optimisation Glandless pumps	2219250
Energy Solutions Glandless pumps	2219285

More suitable services

Extended Warranty Glandless pumps	2219589
Supervision Glandless pumps	2219320
Installation Glandless pumps	2219355
Commissioning Glandless pumps	2219390
Maintenance BASIC Glandless pumps	2219530
Maintenance COMFORT Glandless pumps	2219416
Maintenance PREMIUM Glandless pumps	2219545
Repair Glandless pumps	2219609