



Similar to figure

Data sheet

Hydraulic data

Maximum operating pressure P_N	2 bar
Impeller type	Open multi-channel impeller
Free ball passage of the hydraulics	2 mm
Max. immersion depth	1 m
Min. fluid temperature T_{min}	3 °C
Max. fluid temperature T_{max}	35 °C
Min. ambient temperature T_{min}	3 °C
Max. ambient temperature T_{max}	35 °C

Motor data

Mains connection	1~230 V, 50 Hz
Voltage tolerance	±10 %
Power factor $\cos \varphi_{100}$	0.93
Rated power P_2	0.55 kW
Power consumption $P_{1 \max}$	750 W
Rated current I_N	3.2 A
Starting current I	9.8 A
Activation type	Direct On Line (DOL)
Rated speed n	2900 1/min
Max. switching frequency t	50 1/h
Insulation class	F
Protection class	IP68
Operating mode (immersed)	S1
Operating mode (non-immersed)	S3-25%

Cable

Connection cable length L	4 m
Cable type	H07RN-F
Cable cross-section	3G1 mm ²
Mains plug	CEE 7/7 (Schuko)
Type of connection cable	Non-detachable

Equipment/function

Float switch	yes
Explosion protection type	-
Motor protection	Bimetall

Materials

Pump housing	PP-GF30
Impeller	PPE/PS-GF20
Sealing on pump side	BQ1PFF
Sealing on motor side	NBR
Gasket material	NBR
Motor housing	Stainless steel

Installation dimensions

Pipe connection on the discharge side DN_d	G 1¼
--	------

Pump curves



Fluid media	Water 100 %
Fluid temperature <i>T</i>	20.00 °C
speed at duty point <i>n hydr. @ OP</i>	2,900 1/min

Dimensions and dimensions drawings

Wilo-Drain TMR 32

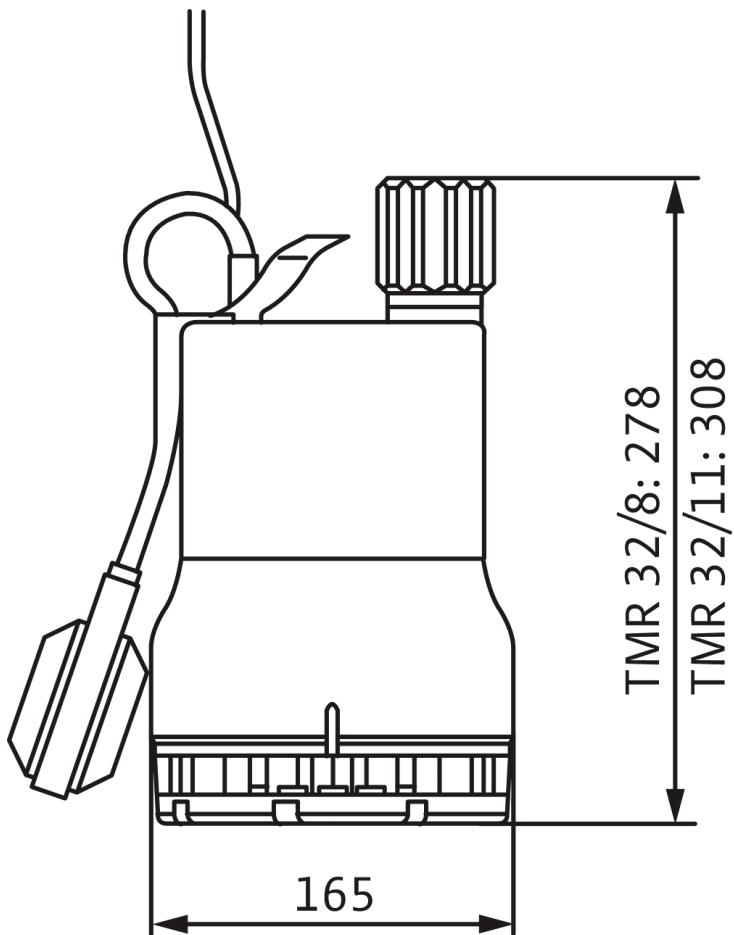

Ordering information

Product data

Brand	Wilo
Product description	Drain TMR 32/11
Article number	4145327 
EAN number	4048482104768
Colour	green/black
Minimum order quantity	1
Date of sales availability	2010-03-01

Packaging

Packaging type	Cardboard box
Packaging property	Sales packaging
Pieces per pallet	1
Number per layer	1

Dimension, weight

Length with packaging	195 mm
Length <i>L</i>	165 mm
Height with packaging	367 mm
Height <i>H</i>	308 mm
Width with packaging	195 mm
Width <i>W</i>	165 mm
Gross weight, approx. <i>m</i>	6.8 kg
Net weight, approx. <i>m</i>	6.3 kg

Tender text

Submersible pump for stationary and portable wet well installation. Pump with fitted float switch for fully automatic operation.

For the pumping in domestic areas of:

- > Sewage not containing faeces
- > Wastewater (with small amounts of sand and gravel)

Sewage pump with depth suction (pumping out up to 2 mm residual water level), open multi-channel impeller

and vertical threaded connection. Pump housing, strainer and impeller made of composite material. 1~ motor (jacket cooling) with integrated operating capacitor and self-switching thermal motor monitoring. Stainless steel motor housing. Oil-filled sealing chamber with double sealing: a rotary shaft seal is installed on the motor side, a mechanical seal on the pump side. Connection cable with float switch and fitted plug (CEE 7/7).

Operating Data

Product data

Impeller type	Open multi-channel impeller
Free ball passage of the hydraulics	2 mm
Maximum operating pressure P_N	2 bar
Max. immersion depth	1 m
Fluid temperature T	3 °C
Max. fluid temperature, for short periods up to 3 min. T	90 °C

Motor data

Mains connection	1~230 V, 50 Hz
Voltage tolerance	±10 %
Power factor $\cos \varphi_{100}$	0.93
Rated power P_2	0.55 kW
Power consumption $P_{1 \max}$	0.75 kW
Rated current I_N	3.2 A
Activation type	Direct On Line (DOL)
Rated speed n	2900 1/min
Max. switching frequency t	50 1/h
Insulation class	F
Protection class	IP68
Operating mode (immersed)	S1
Operating mode (non-immersed)	S3-25%

Cable

Connection cable length L	4 m
Cable type	H07RN-F
Cable cross-section	3G1 mm ²
Mains plug	CEE 7/7 (Schuko)
Type of connection cable	Non-detachable

Equipment/function

Float switch	yes
Explosion protection type	-
Motor protection	Bimetall

Materials

Pump housing	PP-GF30
Impeller	PPE/PS-GF20
Shaft	Stainless steel
Sealing on pump side	BQ1PFF
Sealing on motor side	NBR
Gasket material	NBR
Motor housing	Stainless steel

Installation dimensions

Pipe connection on the suction side D_Ns	-
Pipe connection on the discharge side D_Nd	G 1¼

Ordering information

Brand	Wilo
Product description	Drain TMR 32/11
Net weight, approx. <i>m</i>	6.3 kg
Article number	4145327 

Installation type

Stationary wet well installation

The pumps are immersed in the fluid. Connection to the discharge pipe is normally by a suspension unit. For maintenance purposes, the pumps can be removed from the top of the chamber. There is no need to loosen any screws or drain the water.

For a correct operation of the pumps, it is necessary to know the switching volume. The switching volume is calculated as the difference between the ON and OFF switching points. The OFF-switch point will define by the operating mode for submerged and non-submerged operation of the motor.

Shut-off device kit

Gate valve G1¼, CW617N KIT	2528652
----------------------------	---------

Non-return valve

Non-return valve Rp 1¼	501533696
------------------------	-----------

Mechanical accessories

Fittings

Extension for flushing connection port 600 / 800

Flush connection extension port 600/800	2543035
---	---------

Flushing connection

Flush connection Storz C port 600/800	2543034
---------------------------------------	---------

Non-return valve

Non-return valve Rp 1½	501533696
------------------------	-----------

Shut-off device kit

Gate valve G1¼, CW617N KIT	2528652
----------------------------	---------

Gate valve G1½, CW617N KIT	6096494
----------------------------	---------

Vacuum breaker port 600/800

Vacuum relief valve port 600/800	2543032
----------------------------------	---------

Installation/setup

Operating spanner extension for shutt-off valve port 600/800

Operating key port 600/800	2543006
----------------------------	---------

Pump cover

Pump chamber cover port 600/800 class A15	2543021
---	---------

Pump chamber cover port 600/800 class B125	2543022
--	---------

Pump chamber cover port 600/800 class D400	2543023
--	---------

Sump length extension

Pump chamber extension port 600/800	2543003
-------------------------------------	---------

Pump chamber

Port 600

Port 600.1-1500-03E	2543048
---------------------	---------

Port 600.1-1800-03E	2543049
---------------------	---------

Port 600.1-2250-03E	2544148
---------------------	---------

Electrical accessories

Pump control

Wilo-Control MS-Lift

MS-L-1x4kW-DOL	2539741
MS-L-2x4kW-DOL	2539745

Pump control/accessories

Battery 9V,200mA

NiMh rechargeable battery, 9 V/200 mAh	2522850
--	---------

Alarm signal

AlarmControl

AlarmControl 1	2522846
AlarmControl 2	2522847

DrainAlarm

DrainAlarm	2545133
DrainAlarm FIRST	2550526

Flash light

Mounted Flash light 1~230 VAC	2510429
Flash light 24 VDC	2551612
Flash light 1~230 VAC	2551613

Signal horn

Signal horn 12-24 VDC	2017208
Signal horn 1~230 V	501459398

Small alarm switchgear

Small alarm switchgear KAS	501534094
----------------------------	-----------

Level control

Float switch mini

Mini float switch with 10 m cable	2547569
-----------------------------------	---------

Float switch WA

Float switch WA65 with 5 m cable	503211390
Float switch WA65 with 10 m cable	503211893

Float switch WA65 with 20 m cable	2004431
Float switch WA65 with 30 m cable	2004432
Float switch WA KR1 S with 5 m cable	6082806
Float switch WA KR1 S with 10 m cable	6082807
Float switch WA65 (PSN-X) with 20 m cable	6088843
Float switch WA65 (PSN-X) with 10 m cable	6088844
Float switch WA65 (PSN-X) with 5 m cable	6088845

Float switch WAO

Float switch WAO 65, 5 m cable	503211595
Float switch WAO 65, 10 m cable	2006027
Float switch WAO 65, 20 m cable	2004429
Float switch WAO 65, 30 m cable	2004430

Services

With Wilo as your partner, you can not only be sure of choosing high-quality product solutions, but also of benefiting from a comprehensive, worry-free package of well thought-out services. We collaborate to develop a service concept tailored to your individual needs; with our expertise and personal consultancy, we make sure that the operation of your systems is as energy-efficient, reliable and economical as possible. All the while our competent Wilo service technicians are ready to assist you with fast, reliable and on-time support.

Recommended services

Commissioning Drainage pumps	2219491
Wilo-Live Assistant Service	2216415
Maintenance BASIC Drainage pumps	2219540
Maintenance COMFORT Drainage pumps	2219514
Maintenance PREMIUM Drainage pumps	2219567

More suitable services

Service Package L Drainage pumps	2219719
Service Package M Drainage pumps	2219690
Extended Warranty Drainage pumps	2219465
Supervision Drainage pumps	2219348
Installation Drainage pumps	2219383
System Optimisation Drainage pumps	2219278
Energy Solutions Drainage pumps	2219313
Repair Drainage pumps	2219632