

STORMBOOST

Installation, Operation & Maintenance Instructions

Please leave this instruction booklet with the home-owner as it contains important warranty, maintenance and safety information.

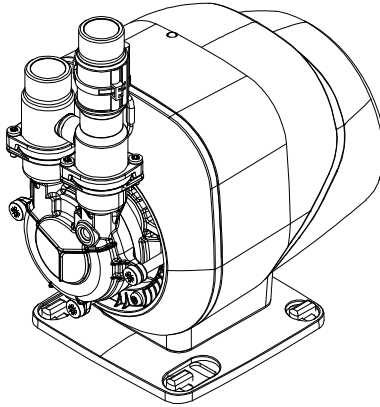

Read this manual carefully before commencing installation.

This manual covers the following products:

STORMBOOST

Pt. No. 47708

Pt. No. 44995

**Please note images are representative only and may not portray
your model**



CONTENTS

1	PRODUCT OVERVIEW	1
2	WARNINGS	2
3	CHECKLIST	5
4	IMPORTANT FACTS - READ BEFORE COMMENCING PUMP INSTALLATION	6
5	LOCATION - GENERAL	7
6	PIPEWORK CONNECTIONS	8
7	ELECTRICAL INSTALLATION	9
8	COMMISSIONING	12
9	MAINTENANCE	13
10	TECHNICAL SPECIFICATION	14
11	TROUBLE SHOOTING GUIDE	15
12	PRODUCT WARRANTY TERMS & CONDITIONS	17
13	DECLARATION OF CONFORMITY	18

1 PRODUCT OVERVIEW

1.1 Product Description

Electric motor-driven peripheral pump with bypass, complete with an automatic control system consisting of flow switch and electronic control.

1.2 Application

The STORMBOOST is a mains booster pump with an automatic control system for domestic use, designed to assist the pressure from the mains supply, where the mains pressure is insufficient. This unit requires a minimum unassisted supply flow of 0.6 l/ min to operate.

The pump is limited to producing a maximum flow of 12 l/min, and a maximum pressure of 3.2 bar.

When the flow from the rising main exceeds the pump output, the patented integral bypass will direct the water into the system as normal.

The STORMBOOST mains booster is a patent granted design.

1.3 Storage

If this product is not to be installed immediately on receipt, ensure that it is stored in a dry, frost and vibration free location in its original packaging.

1.4 Environment Protection

Your appliance contains valuable materials which can be recovered or recycled.

At the end of the products' useful life, please leave it at an appropriate local civic waste collection point.

2 WARNINGS



- This pump must not be used for any other application without the written consent of Stuart Turner Limited.
- The pump is not suitable for heavy commercial/ industrial applications.
- This appliance can be used by children aged from 8 years and above and persons with reduced physical, sensory or mental capabilities or lack of experience and knowledge if they have been given supervision or instruction concerning use of the appliance in a safe way and understand the hazards involved.
- Children shall not play with the appliance.
- Cleaning and user maintenance shall not be made by children without supervision.
- Maximum head (closed valve) 32 metres.
- The motor casing can become very hot under normal operating conditions. Care must be taken to ensure it cannot be touched during operation.



- The electrical installation must be carried out in accordance with the current national electrical regulations.
- The electrical installation must be installed by a qualified person.
- In the interests of electrical safety, a 30 mA residual current device (R.C.D. not supplied) should be installed in the supply circuit. This may be part of a consumer unit or a separate unit.
- Before starting work on the electrical supply ensure power supply is isolated.
- DO NOT allow the supply cord to contact hot surfaces, including the motor shell, pump body or pipework. The cord should be safely routed and secured by cable clips.
- This appliance must be earthed via the supply cord, which must be correctly connected to the earth point located in the terminal box.
- The supply cord and internal wiring within the terminal box are routed and secured to ensure compliance with the electrical standard EN 60335-1.
- It is essential that prior to any disturbance of this internal wiring, all cable routing and securing details are carefully noted to ensure re-assembly to the same factory pattern is always maintained.



- If the supply cord is to be changed or is damaged, it must be replaced with a special cord assembly available from Stuart Turner or one of their approved repairers.

Notes



- This product must be installed in accordance with the current Water Supply (Water Fittings) Regulations.
- Under no account should the internal flow restrictor be removed or replaced with an alternative design.
- Care must be taken to ensure the maximum pressure generated by the pump combined with the incoming mains water pressure does not exceed the pumps maximum operating pressure of 6 bar.

Please read installation details carefully as they are intended to ensure this product provides long, trouble free service. Failure to install the unit in accordance with the installation instructions will lead to invalidation of the warranty.

3 CHECKLIST

IMPORTANT: With the pump removed from its packaging check for any damage prior to installation. If any damage is found contact Stuart Turner Ltd within 24 hours of receipt.

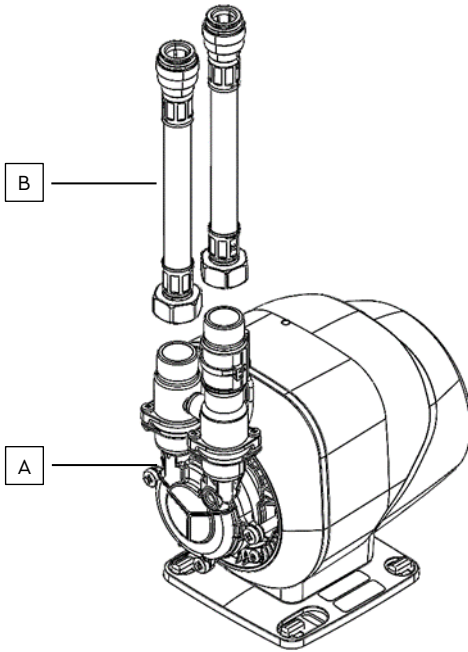

Figure 1

Note: This image is for reference only.

ITEM	DESCRIPTION	QTY	NOTES
A	Pump	1	
B	Hose	2	Not mandatory for installation (see sec 6 pipework connections)
Additional parts required, not supplied:			
	Verifiable Double Check valve	1	
	Full bore isolation valves	2	If not fitting by-pass circuit.
	Full bore isolation valves	3	If fitting by-pass circuit.

4 IMPORTANT FACTS - READ BEFORE COMMENCING PUMP INSTALLATION

4.1 Water Temperature

The water entering the pump must be controlled as follows:

- The maximum allowable water temperature is 23 °C.
- The minimum allowable water temperature is 4 °C.

4.2 Pipework – General

Secure pipework: Ensure pipework to and from pump is independently supported & clipped to prevent forces being transferred to inlet and outlet branches of pump.

Pipework design: Care should be taken in the design of pipework runs to minimise the risk of air locks e.g. use drawn bends rather than 90° bends.

Anti vibration hoses to be installed straight, with no more than 30° bends.

Water flow: An un-assisted flow rate of at least 0.6 l/min is required through the outlets to be pumped for the pump to operate.

Flux: Solder joints must be completed and flux residues removed prior to pump installation (**flux damage will void any warranty**).



- **DO NOT** introduce solder flux to anti-vibration hoses, pump or pump parts.
- **DO NOT** allow contact with oil or cellulose based paints, paint thinners or strippers, acid based descalents or aggressive cleaning agents.

4.3 Plumbing Installation Regulations

The plumbing installation must comply with the current water and building regulations.

The plumbing installation must be installed by a qualified person.

5 LOCATION - GENERAL



- **Access:** For emergencies and maintenance the pump must be easily accessible.
- **Protection:** The pump must be located in a dry position, frost free and protected from freezing. Ensure the pump is in a dry position, away from heat sources, such as radiators and heaters.
- **Ventilation:** Ensure an adequate air flow to cool the pump. Separate the pump from other appliances that generate heat. An 80 mm air gap must be maintained to allow free air flow through the fan cowl and over the motor at all times.
- **Safety:** The motor casing can become very hot under normal operating conditions. Care must be taken to ensure it cannot be touched during operation.
- **Water retention:** Site the pump in a location where in the unlikely event of a water leak, any spillage is contained or routed to avoid electrics or areas sensitive to water damage.
- **Location point:** The pump must be located after the mains water stop cock, in-line to the connection to the boiler. Do not site the pump in the roof space, since air locks can easily result.



- **Pump position:** The pump must be positioned on its anti-vibration mounting feet and as close to the water source as possible.
- **Direction of flow:** Ensure the water flow is in the direction of the arrow, as marked on the flow switch reed clamp.

6 PIPEWORK CONNECTIONS



- **Isolating valves:** Always install isolating valves (not supplied) to both suction and delivery pipe to aid future maintenance.
- **STORMBOOST can be connected to mains water supply via the 15mm push fit hoses (supplied) or connected directly to pipework.**

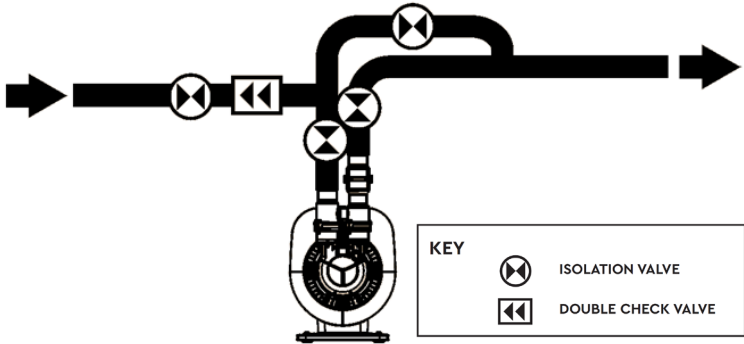

Figure 2

- Incoming mains pressure can vary but must never exceed 6 bar. If there is a possibility of exceeding 6 bar, separate inlet pressure control must be fitted.
- To meet the requirements of the Water Supply (water fittings) Regulations, a type EC – verifiable double check **valve (not supplied) must be fitted** (Fig. 2).
- It is advisable to fit a bypass pipe and isolating valve. This will allow removal of the pump for maintenance and servicing and ensure the water supply into the property is still available during that period (Fig. 2).

7 ELECTRICAL INSTALLATION



- **Regulations:** The electrical installation must be carried out in accordance with the current national electrical regulations and installed by a qualified person.
- **Safety:** In the interests of electrical safety, a 30-mA residual current device (R.C.D. not supplied) must be installed in the supply circuit. This may be part of a consumer unit or a separate unit.
- Before starting work on the electrical installation ensure the power supply is isolated.
- The motor and wiring must not be exposed to water.
- The supply cable must be positioned so that it is not stepped on, cut or damaged.

7.1 Electrical Connection

- The pump is provided with a factory fitted supply cord.

This must be permanently connected to the fixed wiring of the mains supply.
- A means for disconnection must be incorporated in the fixed wiring in accordance with the wiring regulations.
- A suitable method of connection would be via a dedicated double pole switched, fused connection unit complying with BS 1363-4, protected with a fuse (see technical specification section).
- The connection unit should be mounted in an easily accessible position and should be labelled if confusion is possible, to allow easy identification of the STORMBOOST isolating switch.
- **Earthing:** This appliance must be earthed via the supply cord, which must be correctly connected to the earth point located in the terminal box.
- **Additional earthing:** Certain installations may require additional earthing arrangements such as equipotential bonding. Reference should be made to the relevant regulations concerning this subject to ensure compliance.

7.2 Wiring of Connection Unit



WARNING: This appliance must be earthed.

The wires in the mains lead (supply cord) are coloured in accordance with the following code:



- Green and Yellow: Earth
- Blue: Neutral
- Brown: Live

As the colours of the wires in the mains lead of this appliance may not correspond with the coloured markings identifying the terminals in your connection unit proceed as follows:



- The wire which is coloured green and yellow must be connected to the terminal in the connection unit which is marked with the letter E or by the earth symbol: \oplus or coloured green or green and yellow.
- The wire which is coloured blue must be connected to the terminal which is marked with the letter N or coloured black.
- The wire which is coloured brown must be connected to the terminal which is marked with the letter L or coloured red.

7.3 Wiring Diagram



- The supply cord and internal wiring within the terminal box are routed and secured to ensure compliance with the electrical standard EN 60335-1. Do not disturb the internal wiring or factory routing and securing of all internal wiring – (see fig 3).

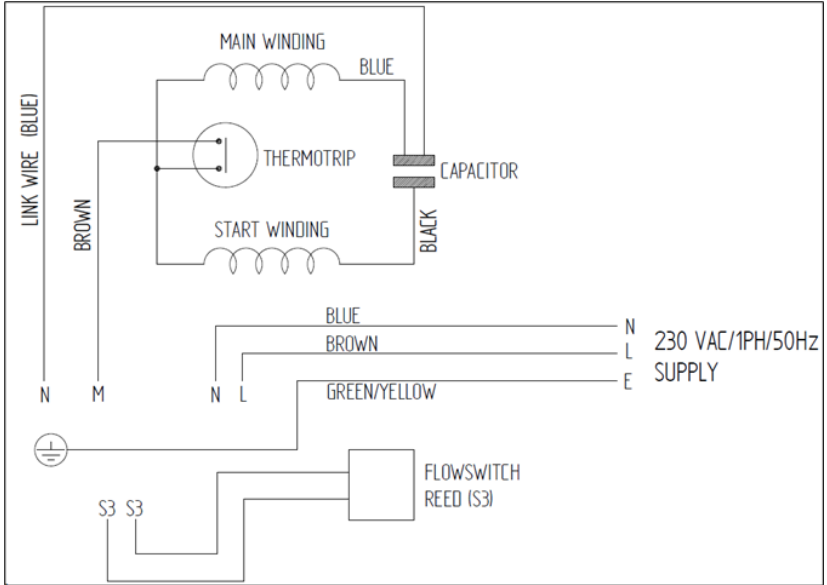

Figure 3

7.4 Fuses

The following fuse size should be used with the appropriate pump.

Model	Fuse Size (AMPS)
All models	5

8 COMMISSIONING

8.1 Priming

- **Priming:** This pump is self-venting. Open the mains stopcock and allow the pump to fill and vent, please note the pump chamber must be full of liquid at all times. Seal damage will result if the pump runs dry. **Do not run the pump dry.**

8.2 Starting

Never operate pump with inlet and/or outlet isolating valves in the closed position. Damage will occur!

- Ensure all outlets are closed, turn power supply 'on'. Check the pump has power, a continuous red light from the power light indicator on top of unit should be visible (Fig 4).

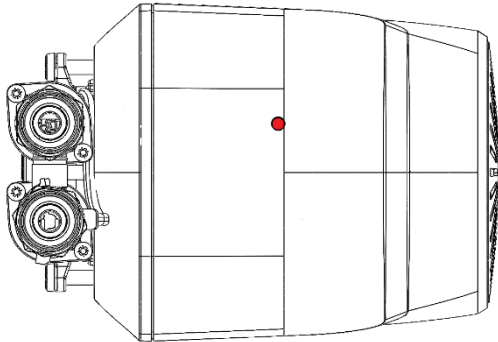

Figure 4

- Open and close all outlets in turn associated with the pump allowing liquid to flow from each outlet until all air is purged. As each outlet is opened and closed the pump will start and stop respectively.
- Any tap or control valve within the system when opened and closed will now turn the pump on/off. Check system for leaks, if clear the system is now operating correctly.
- Carefully check pump and pipework for leaks whilst pump is running and stationary before leaving the installation unattended.

8.3 Technical Support

For Further Technical Support: Phone the Stuart Turner TechAssist team on +44 (0) 800 31 969 80. Our staff are trained to help and advise you over the phone.

Note: When pumps are installed in another manufacturer's original equipment, please contact the manufacturer for advice.

9 MAINTENANCE



No user serviceable parts inside.

There are no user serviceable parts available for the pump.

Disconnect electrical supply before working on the pump.



Turn off water supplies to the pump and release pressure by opening water outlets before attempting maintenance.

9.1 Cleaners, Disinfectants and Descalers



Acid-based descalers and aggressive cleaning agents must not come into contact with the pump. The pump must be removed from the system prior to the use of these products. The system should be flushed to remove all chemicals before the pump is reconnected.

If in any doubt as to the suitability of the chemical solutions, please contact our TechAssist helpline on +44 (0) 800 31 969 80.

When the ambient temperature is lower than 4°C and the pump is not in use, the pump chamber should be drained of water to protect internal components.

10 TECHNICAL SPECIFICATION

Pump Model		STORMBOOST 47708
General	Warranty	5 years
	Conformity certification	UKCA CE
	WRAS	WRAS Approved Product
	Kiwa	Kiwa Reg 4 Certified
Features	Pump type	Peripheral
	Mounting	Floor or plinth
	Anti-vibration feet	✓
	Anti-vibration flexible hoses	✓
	Dry run protection	✓
	Typical noise**	48 dB(A)
Performance	Maximum head - closed valve	3.2 bar (32 metres)
	Maximum flow	12 l/min
	Maximum working pressure*	600 kPa (6.0 bar)
	Maximum ambient air temperature	40°C
	Min / Max water temperature	Min 4°C / Max 23°C
	Flow switch sensitivity	0.6 lpm (approx)
Materials	Pump body	Brass
	Impeller	Brass
	Mechanical seal	EPDM / PTFE / Al Oxide
Connections	Pump	G $\frac{3}{4}$ M
	Hoses	G $\frac{3}{4}$ F - 15mm push-fit
Motor	Type	Induction (thermal trip/auto reset)
	Duty rating	Continuous (S1)
Electrical	Power supply (Vac/Ph/Hz)	165-265V a.c. / 1 / 50-60 Hz
	Power consumption - P1	340 Watts
	Current - full load	1.5 Amps
	Fuse rating	5 Amps
	Power cable length	1.5 metres (pre-wired)
Physical	Enclosure protection	IPX4
	Length	215 mm
	Width	148 mm
	Height - excluding hoses	262 mm
	Weight - including fittings	6.2 kg

*Note: The maximum pressure that can be applied to the pump under any installation conditions.

**Noise: The equivalent continuous A-weighted sound pressure level at a distance of 1 metre.

11 TROUBLE SHOOTING GUIDE

11.1 General Guide

Symptoms	Probable Cause	Recommended Action
Pump will not start	No water	Check required flow of liquid is available to the fittings of approx. 0.6 l/min
	Water supply	Check water supply from mains and all stoptaps are open
	Electrical supply	Check power on indicator light: Continuous red light, power on (Fig. 4) Check wiring connections If flow exists inline with requirements – check that all electric switches are on Is the correct fuse fitted? Check circuit breaker is set
	Faulty reed switch/PCB	Refer to circuit test as detailed in 11.2
	Internal motor thermal trip activated	Wait for thermal trip to auto reset and check that duty point and run time is within specification (see Technical Section)
Pump starts when outlets are off or Pump cycles (hunts) on/off frequently	Leak in system	Check tap washers, w/c valve washers, pipe joints
Pump runs on when all terminal outlets are closed	Leak in system	Check tap washers, w/c valve washers, pipe joints
	Reed clamp out of position	Ensure reed clamp is fitted correctly in location groove (Fig. 5)
	Jammed flow switch	Remove flow switch reed clamp whilst pump is running. If pump stops proceed to isolate the pump electrically and hydraulically and remove brass housing that contains float. Check for free movement
	Faulty reed switch or P.C.B.	Remove flow switch reed clamp whilst pump is running. If pump continues to run, this indicates a closed circuit in either the flow switch reed or P.C.B. in the terminal box. Contact Stuart Turner tech assist

11.2 Flow Switch Circuit Test

1. First confirm visually that the flow switch reed clamp has not been dislodged during handling or installation. The clamp must be fully located within its flow switch body groove as shown (fig 5).

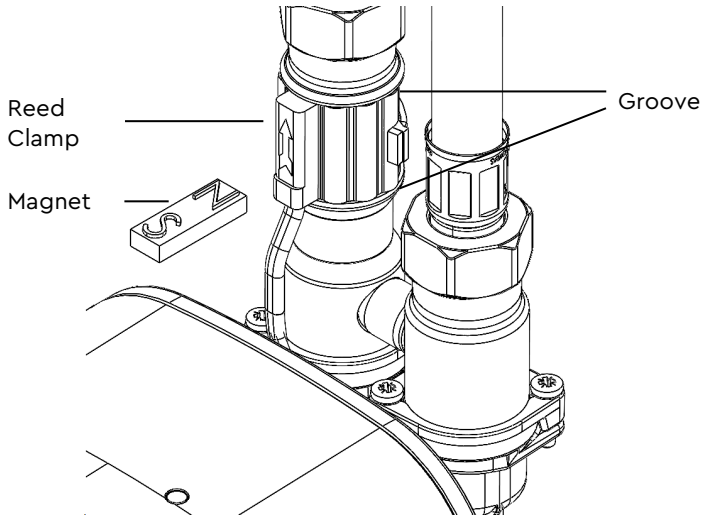

Figure 5

2. To carry out the following test you will need to obtain a magnet, a typical fridge magnet is suitable.
3. Ensure the power supply is switched on.
4. Position the magnet directly in front of the reed clamp as shown. If pump does not start, then slowly move the magnet up and down to a position that exceeds the extent of the reed clamp. The pump should instantaneously start at some point during this extent of movement.

If this does not happen, this indicates a possible fault with the reed switch or the P.C.B which is located within the pump casing. These should be checked electrically. **Consult Stuart Turner for further instructions.**

12 PRODUCT WARRANTY TERMS & CONDITIONS

Congratulations on purchasing a Stuart Turner product

We are confident this product will provide many years of trouble free service as all our products are manufactured to the very highest standard.

The STORMBOOST pump is warranted to be free from defects in materials or workmanship for up to 5 years from the date of purchase.

Within the warranty period we will repair, free of charge, any defects in the product resulting from faults in material or workmanship, repairing or exchanging the whole unit as we may reasonably decide.

*** Important Note**

This extended promotional warranty is only granted under the following conditions:

- 1. That the product is registered on the Stuart Turner web site within 12 months of the purchase date.**
- 2. That a valid receipt or other acceptable form of 'proof of purchase' such as a copy of the installer's invoice/receipt is also uploaded during this registration process.**

Please register your product warranty here:

<https://www.stuart-turner.co.uk/warranty>

Failure to register the product within this period, or failure to upload a valid form of proof of purchase will invalidate the promotional extended warranty and the default product warranty of 1 year will be applicable.

Warranty Exclusions

Not covered by this warranty: Damage arising from incorrect installation, improper use, unauthorised repair, normal wear and tear and defects which have a negligible effect on the value or operation of the pump.

This warranty is in addition to your statutory rights as a consumer. If you are in any doubt as to these rights, please contact your local Trading Standards Department.

Warranty Claim Procedure

In the event of a claim please telephone 'TechAssist' on **+44 (0) 800 31 969 80** or email us at **techassist@stuart-turner.co.uk**

In the event of a claim within the terms of this warranty policy, your receipt or 'proof of purchase' provided during registration will be reviewed.

You should obtain appropriate insurance cover for any loss or damage which is not covered by Stuart Turner Ltd in this provision.

Please make a note for your own reference:

PRODUCT MODEL	SERIAL NO.	DATE PURCHASED
----------------------	-------------------	-----------------------



DECLARATION OF CONFORMITY



Supply of Machinery Regulations - 2008

EN ISO 12100:2010, EN 809:1998+A1:2009/AC:2010

Electrical Equipment Regulations - 2016

EN 60335-1:2012/A2:2019, EN 60335-2-41:2003/A2:2010

EMC Regulations - 2016

EN 55014-1:2017/A11:2020, EN 55014-2:2015, EN 61000-3-2:2014, EN 61000-3-3:2013

EMF Regulations - 2016

EN 62233:2008

RoHS Regulations - 2012

EN IEC 63000:2018

Machinery Directive - 2006/42/EC

EN ISO 12100:2010, EN 809:1998+A1:2009/AC:2010

Low Voltage Directive - 2014/35/EC

EN 60335-1:2012/A2:2019, EN 60335-2-41:2003/A2:2010

EMC Directive - 2014/30/EU

EN 55014-1:2017/A11:2020, EN 55014-2:2015, EN 61000-3-2:2014, EN 61000-3-3:2013

EMF Directive - 1999/519/EC

EN 62233:2008

RoHS Directive - 2011/65/EU

EN IEC 63000:2018

WEEE Directive - 2012/19/EU

IT IS HEREBY CERTIFIED THAT THE STUART ELECTRIC MOTOR DRIVEN PUMP AS SERIAL NUMBER BELOW, COMPLIES WITH THE ESSENTIAL REQUIREMENTS OF THE ABOVE STATUTORY REGULATIONS & E.U. DIRECTIVES.



STUART TURNER LIMITED
HENLEY-ON-THAMES, OXFORDSHIRE
RG9 2AD, ENGLAND.

RESPONSIBLE PERSON AND MANUFACTURER

Signed.....

EU AUTHORISED REPRESENTATIVE

ARC (AUTHORISED REP COMPLIANCE)
GND FLOOR, 71 LOWER BAGGOT
STREET, DUBLIN,
D02 P593, IRELAND.

Stuart Turner are an approved company to BS EN ISO 9001:2015



Stuart Turner Ltd, Henley-on-Thames, Oxfordshire RG9 2AD ENGLAND
Tel: +44 (0) 1491 572655

info@stuart-turner.co.uk | www.stuart-turner.co.uk