

33SVX03G110PT04QBE

Technical data

Company name
Contact
Phone number
e-mail address

Operating data					
1	Pumpe type	vertical		Fluid	Water, pure
2	No. of pumps	1		Operating temperature t A	°C 4
3	Nominal flow	m ³ /h 0		pH-value at t A	7
4	Nominal head	m 0		Density at t A	kg/m ³ 1000
5	Static head	m 0		Vapor pressure at t A	kPa 100
6	Inlet pressure	kPa 0		Kin. viscosity at t A	mm ² /s 1.569
7	Environmental temperature	°C 20		Altitude	0
8	Available system NPSH	m 0			

Pump data		
9	Product version	[X] - Hydrovar X+
10	Operating speed	
11	Stages	3
12	Max. working pressure	kPa 1028.2
13	Head H(Q=0)	m 100
14	Power input P1(max)	kW 12.3
15	Total weight	kg 133.3
16	Power input	kW
17	Overall efficiency	%
18	Shaft power	kW
19	Pump efficiency	%
20	NPSH 3%	m
21		

Materials				
	Pump		Shaft Seal	
22				
23	Pump body	Cast iron	Mechanical seal	
24	Lower support	Cast iron	Uniten (-30 / +120 °C)	
25	Impeller	Stainless steel / AISI 316L		
26	Diffuser	Stainless steel / AISI 304	1 - Rotating part	Silicon Carbide
27	Outer sleeve	Stainless steel / AISI 304	2 - Stationary part	Resin impregnated carbon
28	Shaft	Stainless steel / AISI 431	3 - Elastomers	EPDM
29	Adapter	Cast iron	4 - Springs	AISI 316
30	Wear ring	Technopolymer PPS	5 - Other components	AISI 316
31	Coupling	Cast iron		
32	Upper head	Cast iron		
33	SEAL HOUSING	Cast iron		
34	Coupling protection	Stainless steel / AISI 304		
35	Shaft sleeve and bushing	Tungsten carbide		
36	Bushing for diffuser	Carbon		
37	Fill / drain plugs	Stainless steel / AISI 316		
38	Tie rods	Galvanized steel		
39				
40				
41				

Motor data				
42	Manufacturer	Xylem	Rated voltage	380-480V
43	Specific design	IE5 Three phase motor	Rated current	24,5-22,8 A
44	Type	EXM160B5/4.110DH2	Motor efficiency @400V %	4/4: 91.6 3/4: 90.9 2/4: 89.4
45	Rated power	11 kW	Power factor @400V	0.79
46	Nominal speed	3600 rpm	Weight	kg 64.3
47	Frame size	160		
48	Size	D		

Remarks	
49	
50	
50	
52	

33SVX03G110PT04QBE

Performance curve

Company name
Contact
Phone number
e-mail address

Ø	Pump capacity			Pump head		Frequency	Hz	50/60
	Operating range	η	η	H(Q=0)	η			
	Min. m³/h	Max. m³/h	Max. m³/h	m	Max. m	Operating speed	rpm	
Max.	18.1	48.7	38.8	105	79.9	Nominal flow	m³/h	0
						Nominal head	m	0
						Inlet pressure	kPa	0
						Static head	m	0

Power datas referred to:

hydr. Performance acceptance acc. To EN ISO 9906 Class 3B

Water, pure [100%] ; 4°C; 1000kg/m³; 1.57mm²/s

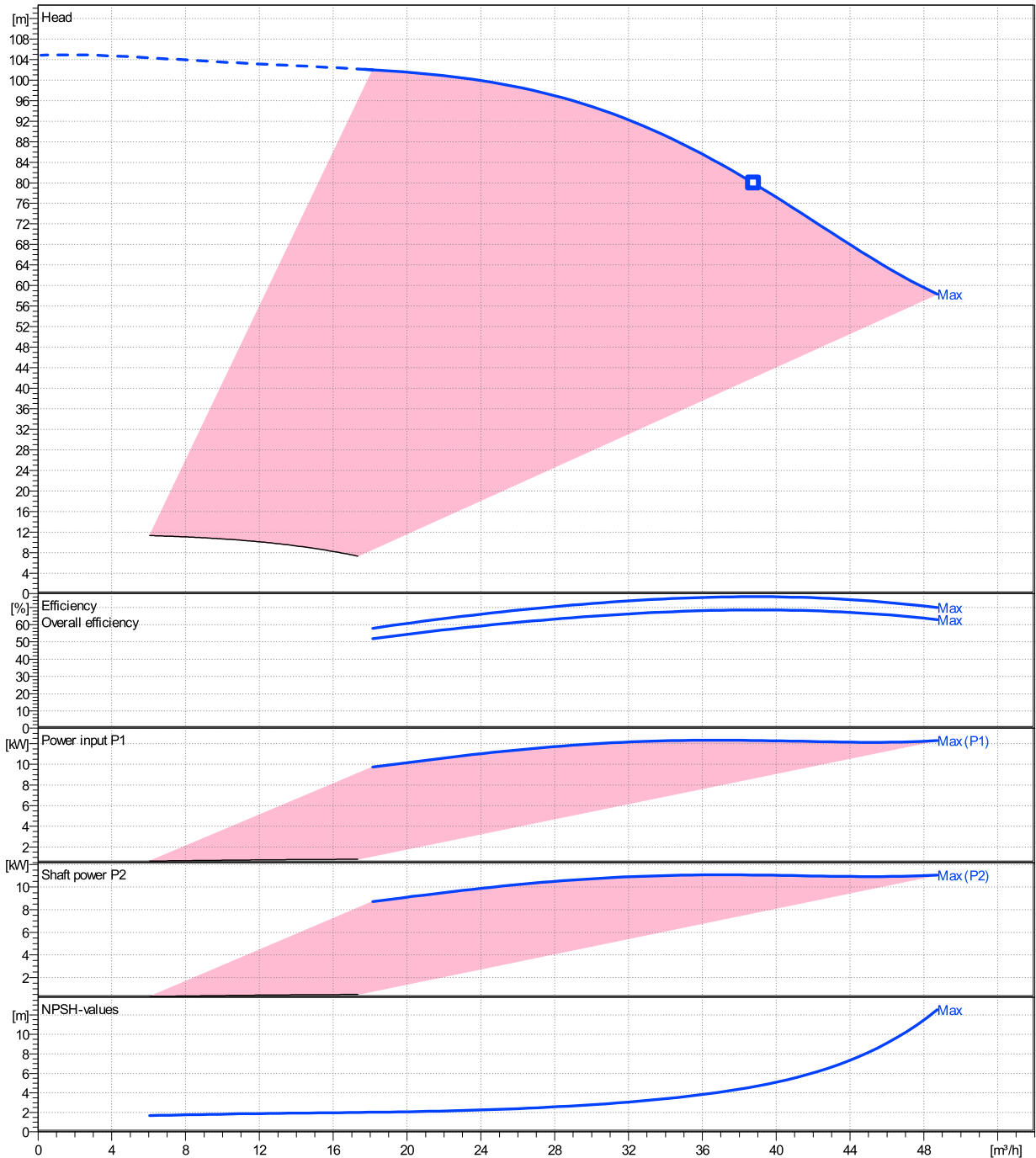

33SVX03G110PT04QBE

Dimensions

Company name
Contact
Phone number
e-mail address

[X] - Hydrovar X+
EXM160B5/4.110DH2

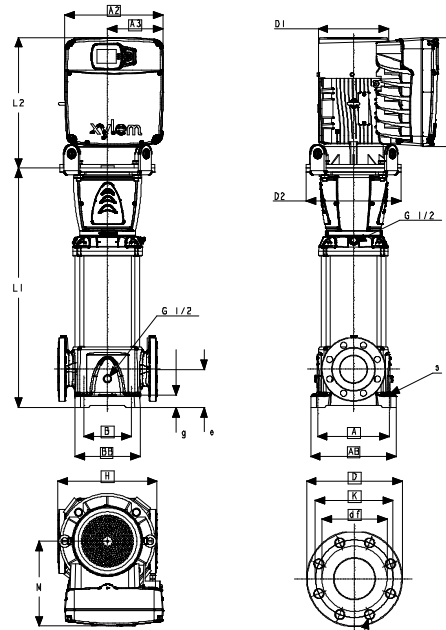

SV G		EN 1092-1 PN 16				EN 1092-1 PN 25			
DN	D	K	df	d1	D	K	df	d1	
65	185	145	118	N.4 x Ø19	185	145	118	N.8 x Ø19	
80	200	160	132	N.8 x Ø19	200	160	132	N.8 x Ø19	
100	220	180	156	N.8 x Ø19	235	190	156	N.8 x Ø23	
125	260	210	184	N.8 x Ø19	280	220	184	N.8 x Ø28	

SV N, P		EN 1092-1 PN 16				EN 1092-1 PN 25			
DN	D	K	df	d1	D	K	df	d1	
65	185	145	122	N.4 x Ø19	185	145	122	N.8 x Ø19	
80	200	160	138	N.8 x Ø19	200	160	138	N.8 x Ø19	
100	220	180	158	N.8 x Ø19	235	190	162	N.8 x Ø23	
125	260	210	184	N.8 x Ø19	280	220	184	N.8 x Ø28	

Dimensions [mm]	
A	240
A1	400
A2	362
A3	205
AB	290
B	170
BB	220
D1	260
D2	350
DN	65
e	105
g	30
H	320
L1	694
L2	404
M	312
s	4xØ15
Weight	
Total weight	133.3 kg

Dimensions and weight without obligation

Project	Xylect-22265084	Created by		Last update	5/9/2024
Block	33SVX03G110PT04QBE	Created on	5/9/2024		

33SVX03G110PT04QBE

Technical data

Company name
Contact
Phone number
e-mail address

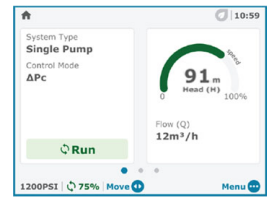
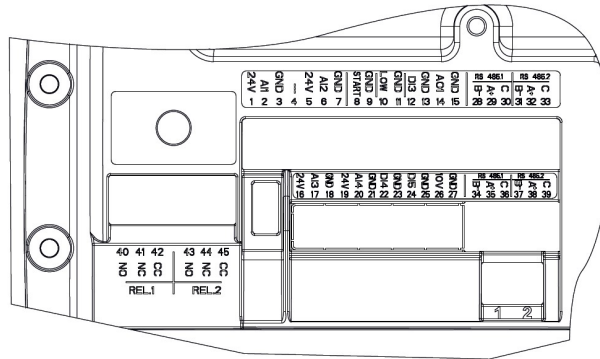

REF.	ITEM	DESCRIPTION	DEFAULT
1		Power supply +24 VDC, max. 60mA (total, terminals 1 + 5)	
2	Analog Input 1	Configurable Analog Input 1	Pressure Sensor 1
3		Electronic GND	
4	Not used	Internal use - Do not connect	
5		Power supply +24 VDC, max. 60mA (total, terminals 1 + 5)	
6	Analog Input 2	Configurable Analog Input 2	Not used
7		Electronic GND	
8	External Start/Stop	Start/Stop digital input, +24 VDC internal pull-up, 6mA contact current	-
9		Electronic GND	
10	External Lack of Water	Low water digital input, +24 VDC internal pull-up, 6mA contact current	-
11		Electronic GND	
12	Digital Input 3	Configurable Digital Input 3, +24 VDC internal pull-up, 6mA contact current	Solo Run
13		Electronic GND	
14	Analog Output	Configurable Analog Output	Motor Speed
15		Electronic GND	
16		Power supply +24 VDC, max. 60mA (total, terminals 16 and 19)	
17	Analog Input 3	Configurable Analog Input 3	Not used
18		Electronic GND	
19		Power supply +24 VDC, max. 60mA (total, terminals 16 and 19)	
20	Analog Input 4	Configurable Analog Input 4	Not used
21		Electronic GND	
22	Digital Input 4	Configurable Digital Input 4, +24 VDC internal pull-up, 6mA contact current	Not used
23		Electronic GND	
24	Digital Input 5	Configurable Digital Input 5, +24 VDC internal pull-up, 6mA contact current	Not used
25		Electronic GND	
26	10 VDC supply	Power supply +10 VDC, max. 3mA	-
27		Electronic GND	
28		RS485 port 1 : RS485-1B N (-)	
29	Communication bus 1	RS485 port 1 : RS485-1A P (+)	Multipump
30		RS485 port 1 : RS485-COM	
31		RS485 port 2 : RS485-2B N (-)	
32	Communication bus 2	RS485 port 2 : RS485-2A P (+)	Modbus
33		RS485 port 2 : RS485-COM	
34		RS485 port 1 : RS485-1B N (-)	
35	Communication bus 1	RS485 port 1 : RS485-1A P (+)	Multipump
36		RS485 port 1 : RS485-COM	
37		RS485 port 2 : RS485-2B N (-)	
38	Communication bus 2	RS485 port 2 : RS485-2A P (+)	Modbus
39		RS485 port 2 : RS485-COM	
40		Configurable relay 1: Normally Open	
41	Relay 1	Configurable relay 1: Normally Closed	Running
42		Configurable relay 1: Common Contact	
43		Configurable relay 2: Normally Open	
44	Relay 2	Configurable relay 2: Normally Closed	Error
45		Configurable relay 2: Common Contact	