

## 22SVX07T110PT04QBE

### Technical data

Company name  
Contact  
Phone number  
e-mail address

#### Operating data

1	Pumpe type	vertical	Fluid	Water, pure
2	No. of pumps	1	Operating temperature t A	°C 4
3	Nominal flow	m <sup>3</sup> /h 0	pH-value at t A	7
4	Nominal head	m 0	Density at t A	kg/m <sup>3</sup> 1000
5	Static head	m 0	Vapor pressure at t A	kPa 100
6	Inlet pressure	kPa 0	Kin. viscosity at t A	mm <sup>2</sup> /s 1.569
7	Environmental temperature	°C 20	Altitude	0
8	Available system NPSH	m 0		

#### Pump data

9	Product version	[X] - Hydrovar X+
10	Operating speed	
11	Stages	7
12	Max. working pressure	kPa 1551.5
13	Head H(Q=0)	m 160
14	Power input P1(max)	kW 12.4
15	Total weight	kg 84.0
16	Power input	kW
17	Overall efficiency	%
18	Shaft power	kW
19	Pump efficiency	%
20	NPSH 3%	m
21		

#### Materials

Pump		Shaft Seal		
22				
23	Pump body	Stainless steel / AISI 304	Mechanical seal	
24	Impeller	Stainless steel / AISI 304	Uniten (-30 / +120 °C)	
25	Diffuser	Stainless steel / AISI 304		
26	Outer sleeve	Stainless steel / AISI 304	1 - Rotating part	Silicon Carbide
27	Shaft	Stainless steel / AISI 304	2 - Stationary part	Resin impregnated carbon
28	Adapter	Cast iron	3 - Elastomers	EPDM
29	Base	Aluminium	4 - Springs	AISI 316
30	Coupling	Aluminium	5 - Other components	AISI 316
31	SEAL HOUSING	Stainless steel / AISI 304		
32	Coupling protection	Stainless steel / AISI 304		
33	Shaft sleeve and bushing	Tungsten carbide		
34	Fill / drain plugs	Stainless steel / AISI 304		
35	Tie rods	Galvanized steel		
36	Wear ring	Technopolymer PPS		
37				
38				
39				
40				
41				

#### Motor data

42	Manufacturer	Xylem	Rated voltage	380-480V
43	Specific design	IE5 Three phase motor	Rated current	19,8-16,5 A
44	Type	EXM160B5/4.110CH2	Motor efficiency @400V %	4/4: 89.7 3/4: 89.5 2/4: 88.2
45	Rated power	11 kW	Power factor @400V	0.93
46	Nominal speed	3600 rpm	Weight	kg 51.6
47	Frame size	160		
48	Size	C		

#### Remarks

49	
50	
50	
52	

Project	Xylect-22264561	Created by		Last update	5/9/2024
Block	22SVX07F110PT04QBE	Created on	5/9/2024		

## 22SVX07T110PT04QBE

### Performance curve

Company name  
Contact  
Phone number  
e-mail address

Ø	Pump capacity			Pump head		Frequency	Hz	50/60
	Operating range	η	η	H(Q=0)	η			
	Min. m³/h	Max. m³/h	Max. m³/h	m	m	Operating speed	rpm	
Max.	13.1	34.2	23.5	158	125	Nominal flow	m³/h	0
						Nominal head	m	0
						Inlet pressure	kPa	0
						Static head	m	0

**Power datas referred to:**

Water, pure [100%] ; 4°C; 1000kg/m³; 1.57mm²/s

hydr. Performance acceptance acc. To EN ISO 9906 Class 3B

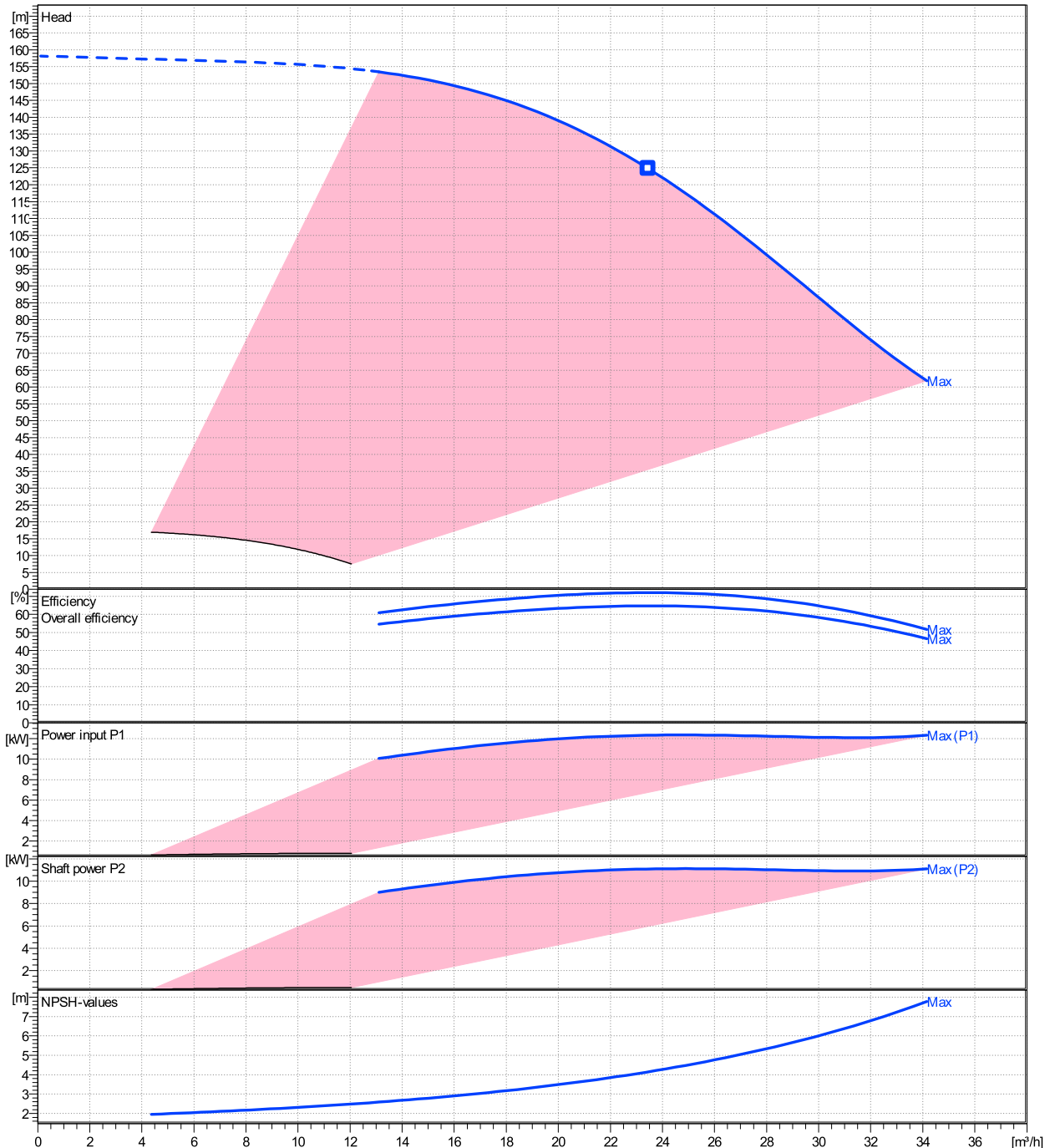

## 22SVX07T110PT04QBE

## Dimensions

Company name  
Contact  
Phone number  
e-mail address

[X] - Hydrovar X+  
EXM160B5/4.110CH2

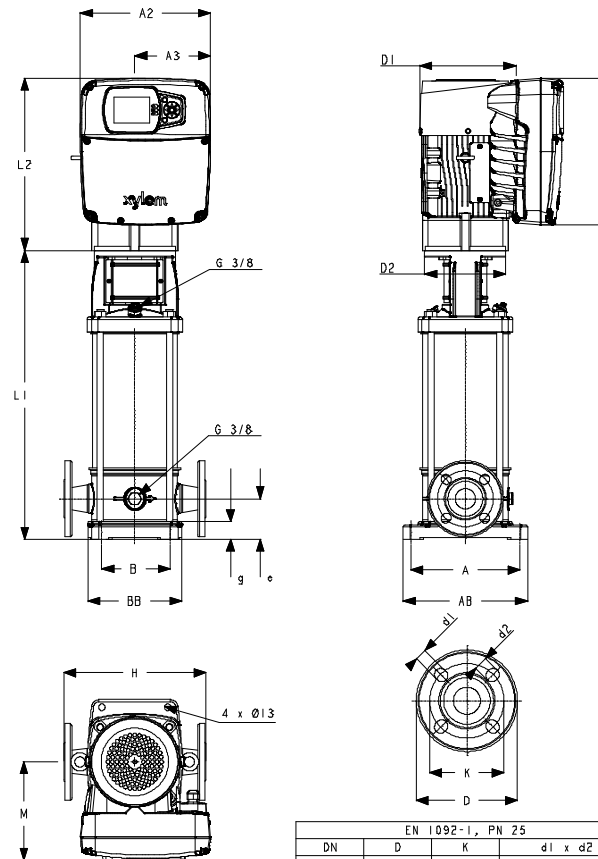

Dimensions [ mm ]	
A	215
A1	329
A2	302
A3	175
AB	245
B	130
BB	185
D1	220
D2	350
DN	50
e	90
g	30
H	300
L1	756
L2	404
M	241
Weight	
Total weight	84 kg

### Dimensions and weight without obligation

Project Xlect-22264561  
Block 22SVX07F110PT04QBE

Created by  
Created on 5/9/2024

Last update 5/9/2024

**22SVX07T110PT04QBE**

**Technical data**

Company name  
Contact  
Phone number  
e-mail address

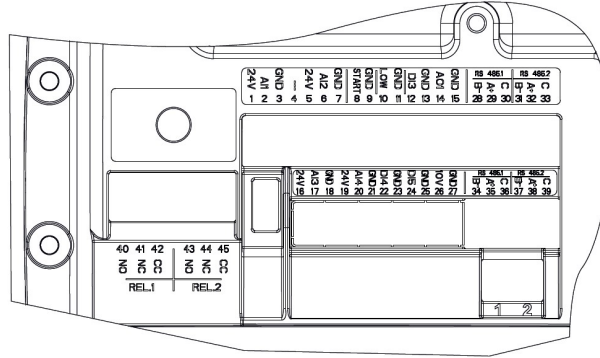

REF.	ITEM	DESCRIPTION	DEFAULT
1		Power supply +24 VDC, max. 60mA (total, terminals 1 + 5)	
2	Analog Input 1	Configurable Analog Input 1	Pressure Sensor 1
3		Electronic GND	
4	Not used	Internal use - Do not connect	
5		Power supply +24 VDC, max. 60mA (total, terminals 1 + 5)	
6	Analog Input 2	Configurable Analog Input 2	Not used
7		Electronic GND	
8	External Start/Stop	Start/Stop digital input, +24 VDC internal pull-up, 6mA contact current	-
9		Electronic GND	
10	External Lack of Water	Low water digital input, +24 VDC internal pull-up, 6mA contact current	-
11		Electronic GND	
12	Digital Input 3	Configurable Digital Input 3, +24 VDC internal pull-up, 6mA contact current	Solo Run
13		Electronic GND	
14	Analog Output	Configurable Analog Output	Motor Speed
15		Electronic GND	
16		Power supply +24 VDC, max. 60mA (total, terminals 16 and 19)	
17	Analog Input 3	Configurable Analog Input 3	Not used
18		Electronic GND	
19		Power supply +24 VDC, max. 60mA (total, terminals 16 and 19)	
20	Analog Input 4	Configurable Analog Input 4	Not used
21		Electronic GND	
22	Digital Input 4	Configurable Digital Input 4, +24 VDC internal pull-up, 6mA contact current	Not used
23		Electronic GND	
24	Digital Input 5	Configurable Digital Input 5, +24 VDC internal pull-up, 6mA contact current	Not used
25		Electronic GND	
26	10 VDC supply	Power supply +10 VDC, max. 3mA	-
27		Electronic GND	
28		RS485 port 1 : RS485-1B N (-)	
29	Communication bus 1	RS485 port 1 : RS485-1A P (+)	Multipump
30		RS485 port 1 : RS485-COM	
31		RS485 port 2 : RS485-2B N (-)	
32	Communication bus 2	RS485 port 2 : RS485-2A P (+)	Modbus
33		RS485 port 2 : RS485-COM	
34		RS485 port 1 : RS485-1B N (-)	
35	Communication bus 1	RS485 port 1 : RS485-1A P (+)	Multipump
36		RS485 port 1 : RS485-COM	
37		RS485 port 2 : RS485-2B N (-)	
38	Communication bus 2	RS485 port 2 : RS485-2A P (+)	Modbus
39		RS485 port 2 : RS485-COM	
40		Configurable relay 1: Normally Open	
41	Relay 1	Configurable relay 1: Normally Closed	Running
42		Configurable relay 1: Common Contact	
43		Configurable relay 2: Normally Open	
44	Relay 2	Configurable relay 2: Normally Closed	Error
45		Configurable relay 2: Common Contact	