

powertank.co.uk



O&M MANUAL

 **POWER TANK**
Water Boosting Systems

by Pedrollo Distribution

Table of Contents

General	3
Installation Checklist	4
Location Consideration	5
Installation Diagrams	6
Electrical Installation	7
Commissioning	9
Water Quality	10
Pump Specification	10
Controller Specific Instruction & Troubleshooting	12
Declaration of Conformity	18
Directives and National Implementation Provisions	19
Powertank Range	20
Commissioning Checklist	22



General

Delivery and Handling

The weight and size of the Powertank may require the aid of lifting equipment and must be handled in a safe manner.

Inspection

On delivery, the Powertank should be inspected thoroughly and any damage reported to the supplier as soon as possible. This should be confirmed in writing within 48 hours.

Applications

The Powertank is designed for domestic and light commercial pressure boosting.

The Powertank should not be installed in areas that are classified as hazardous or where there is a risk of an explosion or harm to people. The manufacturer does not accept responsibility if the Powertank is used to pump liquids other than clean water unless suitability has previously been agreed in writing.

Warranty

All mechanical components of the Powertank are covered by a 12 month warranty against manufacturing defects. In case of failure please contact the Technical Department on 01543 415200.

Site Storage

Should a Powertank need to be stored before installation it should be in a safe place away from moisture, dust and frost.

Installation Checklist

1. Check the unit for any visual defects. Contact your supplier immediately if any are found.
2. Choose a suitable location for installation. Please ensure the unit is fitted and supported in accordance with these instructions.
 - Check that the cold water storage tank capacity is designed to meet your water consumption demands.
 - Tank Drip Trays or banded tanks are to be used for Installations that would be sensitive to leakage.
3. Connect the inlet pipe work and overflow pipe work as per the installation diagram.
 - Good quality full bore Isolation Valves should be fitted before and after the unit to allow for reliable service or repair.
 - We strongly advise that a suitably designed bypass is installed to allow for servicing.
 - Pipe work should be easy to disassemble. Consider the use of "Speedfit" or similar plastic pipework systems, or flexible hosing with a suitable pressure rating, for the last 1.0 mtr (approx.) of pipe work connecting to the unit. This will reduce noise transmission and accommodate movement of the unit, avoiding stressing the Powertank connections.
 - Pipework installations should be in accordance with local water authority regulations.
 - The Powertank COMPACT is designed to accept a 40mm overflow pipe. Other tanks should be fitted with overflows in accordance with local regulations. Ensure that overflow water is piped away properly.
4. Fill the storage tank with water through the fill valve before connecting the discharge pipe work to allow air to escape from the pump. Please ensure the fill valve fitted is suitable for the incoming water pressure.
5. Once the tank is full, connect the discharge pipe work as per the installation diagram.
 - The discharge pipe work must be, at a minimum, the same size as the Powertank inlet supply; if it is smaller the result will be reduced pressure and flow at the outlets.
 - The discharge pipe work must be properly secured so once the Powertank is fitted there are no stressed internal pipe work.
6. In accordance with the latest IEE regulation all electrical connections should be carried out by a qualified electrician. The Powertank must be earthed. It is recommended that an earth leakage circuit breaker (ELCB) is fitted on the incoming electrical supply.
 - Make sure the electrical supply is fully isolated and cannot be turned on before working on the pump, motor, controller or any part of the unit.
 - Do not turn on electrical supply to the Powertank without ensuring all electrical fittings and all covers are intact and fully isolated from human touch during operation.

Location Consideration

The Powertank is not recommended to be fitted above ceilings.

Installations in loft areas are not recommended due to the weight of the tank when full of water and the increased potential for damage in the event of water leakage or spillage. Sound also travels through rafters and it is likely that such an installation will be noisy compared to an installation on a solid base.

Installations significantly higher than the mains water stop tap will reduce the refill rate of the tank.

1. The Powertank should be installed in a dry, well-ventilated area where it is not exposed to extreme temperature or frost. An ambient temperature below 20 °C is required to limit bacteria growth. Powertanks may be located outdoors in a weather, frost and rodent proof enclosure which should be adequately ventilated during warm weather.
2. All pipe work that may be exposed to freezing condition should be fully protected.
3. Powertank must be positioned such that there is safe access for examination and service in compliance with health and safety practice.
4. Bunded tank options and drip trays are available for some of the Powertank range and these can be used in areas where water spillages or leakages can cause damage.
5. A litre of water weighs 1kg so a 200 litre tank will weigh 200kgs plus the weight of the tank, pumps etc. See our technical data sheet for the dry weights of each Powertank. Please check that your proposed installation site can support this level of load evenly.
6. There should ideally be adequate lighting in the location of the Powertank for ease of maintenance.
7. There should be sufficient space allowed above the tank to allow for correct installation of the pipe work and the removal of the pump from the tank for inspection and maintenance. We recommend the space allowed should be at least two-thirds the height of the tank.

Foundation & Mounting

Powertank must be mounted on a solid foundation to support the weight of the unit. Surfaces must be flat and level to spread weight load evenly. The recommended surface for a Powertank is a concrete plinth or floor. We do not recommend installation of Powertank units on wooden structures in any situation where noise or vibration may be an issue.

Storage Tank

Powertanks incorporate a cold water storage tank with a type AF Air gap as standard (AB Air gap for the Compact model) and when used with a mains connection must be installed in accordance with the water regulations. All the wetted parts of the Powertank are potable quality and suitable for use with drinking water. It should be noted that the quality of stored water deteriorates over time if ambient temperature is greater than 20 degrees Celsius (>20 °C). If the tank is to be left idle for any length of time, it is recommended that it is completely drained before being put back into use. It is recommended that tanks are drained and cleaned periodically, according to the conditions of use, to avoid any problems.

Assist Tank

Where additional water storage is required, an assist tank can be used to increase the capacity. It is important to maintain the "flow through" of all the water and to achieve this the incoming water supply should be delivered to the assist tank only. Please contact us for guidance on a particular installation.

Location Consideration

Selection of Drip Trays Available

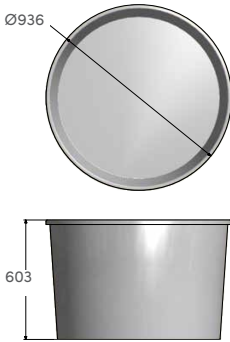

Drip Tray for 200/300ltr tank

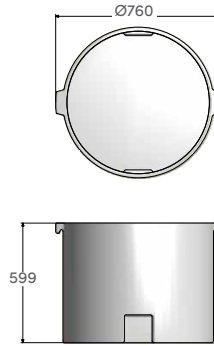

Drip Tray for 500/750ltr Tank

Pipework Installation

It is recommended to install a cold water mains bypass to allow an emergency water supply to the property to be maintained during service or failure. This allows the home owner to have a low pressure supply available while the unit is out of commission. The bypass must be installed in accordance with the water By-law regulations and should be drained to prevent water stagnation when not being used.

Installation Diagrams

Compact Installation Diagram

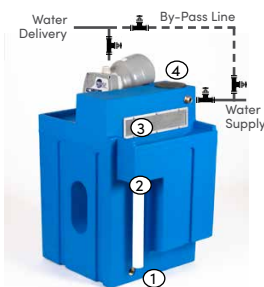

Typical example of installation

1. Tank drain off
2. Overflow connection
3. Integral overflow weir
4. Fill valve

 Isolation Valve

PowerTank Utility Installation Diagram

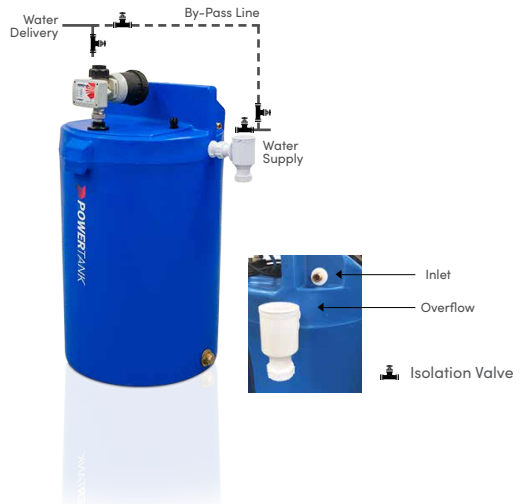

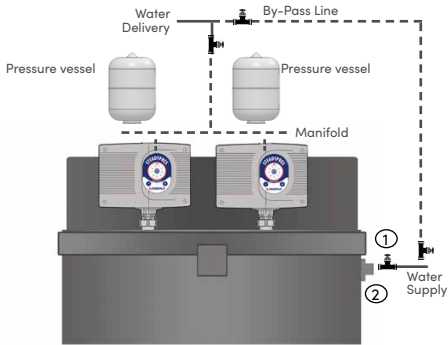

Typical example of installation

Powertank Twin Pump Installation Diagram

1. Fill valve
2. Overflow connection

Isolation Valve

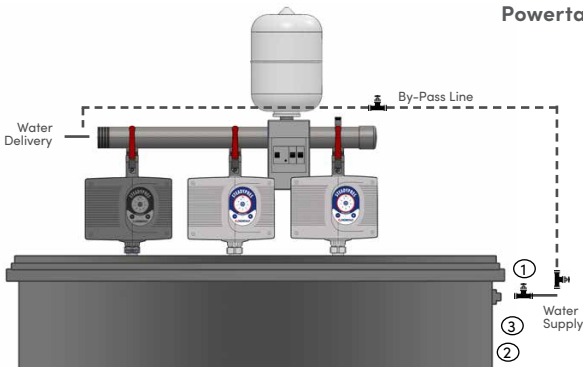
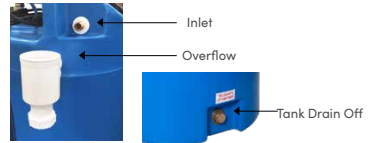

Typical example of installation

Powertank Industrial Installation Diagram

1. Fill valve
2. Warning pipe
3. Overflow connection

Isolation Valve

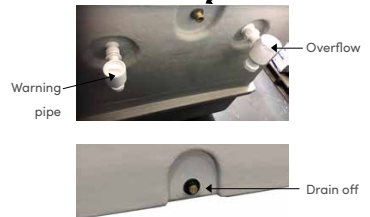

Electrical Installation

Powertanks supplied with a fitted plug may be used with a domestic 13A power socket. The plugs have a 13A fuse and, in the event of failure, should be replaced with the same value. Pumps supplied with only a power cable are designed for professional installation and should be connected by a suitably qualified electrician in accordance with the latest IEE regulations.

Ensure that the electrical supply is fully isolated before removing any electrical covers. The Powertank is fitted with a 3 core cable and the earth wire must be connected. It is recommended that an earth leakage circuit breaker (ELCB) is fitted on the incoming electrical supply.

Single phase Powertanks are suitable for voltage supply 230v +/- 10% with a suitable MCB or Fuse rated at a maximum of 13A. See below for the full load current of our different Powertank Pump options.

Electrical Installation Continued

Power tank Model	Full Load Current
Power tank Fixed Speed	3.4 Amps
Power tank Variable Speed (Compact Model)	5.2 Amps
Power tank Variable Speed	6.3 Amps
Power tank PLUS Variable Speed	9.3 Amps
Power tank TWIN Variable Speed	12.6 Amps
Power tank TRIPLE Variable Speed	18.9 Amps

Wiring Connections

The **Power tank Industrial** unit has provision for an external level switch input and a volt free general alarm output (BMS connection). Connections for these features are made within the main wiring as per the diagrams below.

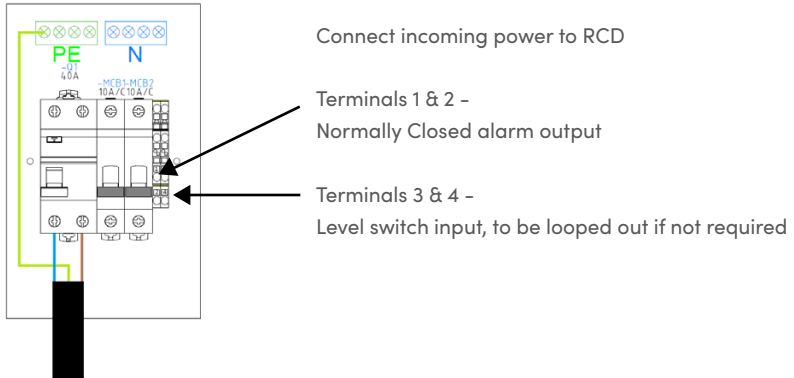

Commissioning

1. Make a visual check to make sure all pipe work and electrical connections are connected securely in a safe manner.
2. If present, close any isolation valves on the Bypass and disconnect the bypass if necessary to comply with water regulations.
3. Check that the Pre-charge air pressure in the pressure vessel is set 0.2 bar below the cut in pressure. For a standard fixed speed Powertank with a 1.5 bar Presflo this would be 1.3 bar. For variable speed units with user selectable start pressures it should be set according to your required duty point.
4. Check and open the isolation valves on the inlet to the tank.
5. If the tank isn't already filled, loosen the outlet connection to allow air to escape while the tank is filling.
6. Ensure the tank is full and there is no discharge from the overflow connection.
7. Check that the outlet connection has been correctly tightened again and close the valve you have fitted on the outlet pipe.
8. Open the closest cold water outlet to the tank.
9. Check that the unit is plugged in or the electrical supply cables are correctly connected to the mains isolator switch.
10. Turn on the power. The control unit should turn on and the pump start to run for up to 30 seconds.
11. Slowly open the Isolating valve to fill the pipe work with water, the pump should start automatically. If it does not then you may need to press the "reset" button or turn the power on again.
12. If the controller displays dry running after approximately 10 seconds it is likely that there is air trapped in the pump. Bleed this air out by loosening the lower connection of the control unit before resetting the controller. This is O ring sealed and does not need to be overtightened or have any joint sealer.
13. Check that water is flowing from the open tap/outlet and then close it and check that the pump turns off. There will always be a time delay of 10 – 20 seconds until the pump stops in normal operation.
14. Check all pipe work for leaks.
15. For variable speed Powertanks, check the operating pressure and adjust as required.

Water Quality

In the event that the water remains unused inside the tank for an extended period, it should be drained and flushed to maintain water quality. Tanks may be drained by using the pump to empty it and/or via the drain plug at the base. For commercial applications the tank should be cleaned in accordance with the relevant regulations and it is recommended that domestic systems are drained and cleaned twice a year or as required by the circumstances of the installation.

Pump Specification

Maximum Operating Conditions

	Top Multi/ Top Multi Tech	NK/UP
Liquid Temperature	+40°C	+40°C
Maximum Pressures	4.2bar	9.5 bar
Noises level of the Powertank Set	≥48-55dB	≥48-55dB

Pump Types specifications

Powertank Models	Power		Pressure	1 Bar	2 Bar	3 Bar	4 Bar	5 Bar	6 Bar
	kW	HP							
Fixed Speed	0.55	0.75	Q l/min	73	57	40	10	-	-
Variable Speed	0.75	1		80	80	80	68	50	14
Variable Speed (Compact)	0.55	0.75		80	80	66	40	-	-
Variable PLUS	1.5	2		160	160	138	107	50	-
Variable TWIN	1.5	2		160	160	160	136	100	28
Variable TRIPLE	2.25	3		240	240	240	204	150	42

Vessel Pre-charge Pressure

The air pre-charge in the pressure vessel should be set 0.2 bar below the pump start pressure for maximum effectiveness. It is recommended to check the Tank air pressure every 4-6 months. For fixed speed Powertanks the air pressure in the vessel should be 1.3 bar.

Fixed Speed Powertanks - Pressure Settings

The start pressure is 1.5 bar on a standard fixed speed Powertank and is not user adjustable. These Powertanks are not suitable for installations where the highest outlet is more than 12 vertical metres above the Powertank, please consult our Technical Department for heights greater than this.

Variable Speed Powertanks – Pressure Settings



The constant operating pressure is factory set to 3.0 bar. This can be adjusted as detailed below. The maximum pressure setting should not be set higher than the pressure capability of the pump, this prevents the system operating correctly and will cause a false “no water” error. The maximum recommended settings are:

Powertank (Compact): 4.0 bar

Powertank: 5.0 bar

Variable Speed Powertanks – Pressure adjustment:

The WORKING PRESSURE is displayed via the GREEN LEDS that light up on the control panel, and which ranges from a minimum of 1 bar to a maximum of 9 bar.

- A fixed GREEN LED indicates a full 1 bar of pressure 
- A flashing GREEN LED indicates a 0.5 bar of pressure 

To adjust the WORKING PRESSURE:

- Press the + key to display the working pressure.
- Press the keys + or - to increase or decrease the WORKING PRESSURE.
- On each press of the key + or - you increase or decrease the value in steps of 0.5 bar.

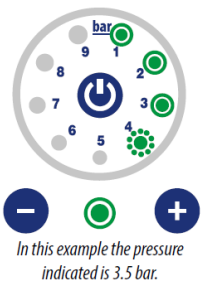

Variable Speed Powertank Vessel Installation

The supplied 8l vessel should be tee'd into the outlet pipework before the first draw off. The vessel should be vertical and 1" FFF tee is supplied so the vessel can be installed directly on top of the Steadypress controller or remotely if preferred.



Controller Specific Instructions & Troubleshooting

Operation: Presflo – Fixed Speed Controller

1 No power supply

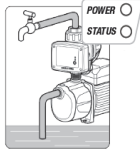

PRESFLO® is switched off.

Press briefly or hold down = nothing happens

Power is restored = PRESFLO® resumes NORMAL SERVICE and starts the pump (if necessary).



3 Out of service

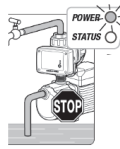

The pump has been stopped manually. The pump will remain inactive until a new command is given.
Press briefly = nothing happens

Hold down = the pump resumes NORMAL SERVICE. See points 2a - 2b.



2a NORMAL SERVICE: the pump is inactive.

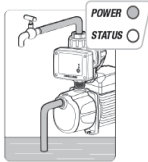

The system is pressurised. All taps are turned off. There is no demand for water. PRESFLO® detects an assembly pressure higher than that of the start-up pressure (Pm) and no flow.

Press briefly = the pump is started manually and runs for a few seconds before stopping again.



Hold down = the pump is put OUT OF SERVICE. For instructions on how to reactivate the pump, see point 3.



A tap is turned on = as soon as the pressure falls below the start-up pressure (Pm), the pump is started.

4a ERROR: stopped temporarily due to DRY RUNNING

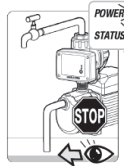

(See NOTE 1)
PRESFLO® has detected that the pump is dry running and has therefore stopped it TEMPORARILY.

Press briefly = the pump is started and manually and resumes NORMAL SERVICE. See points 2a - 2b.

Hold down = the pump is put OUT OF SERVICE. For instructions on how to reactivate the pump, see point 3.



2b NORMAL SERVICE: the pump is running

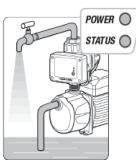

The assembly requires water. One or more taps are turned on. PRESFLO® detects a flow; the assembly pressure is normally higher than the START-UP pressure, but it may also be lower.

Press briefly or hold down = the pump is stopped and put OUT OF SERVICE. For instructions on how to reactivate the pump, see point 3.



The taps are turned off = if there is no flow for a few seconds, the pump is stopped.

4b ERROR: temporary shut down due to FREQUENT START UP

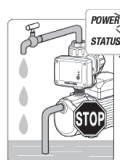

(see NOTE 2)
PRESFLO® has detected that the pump starting-up too often and has therefore stopped it TEMPORARILY.

Press briefly = the pump is started and manually and resumes NORMAL SERVICE. See points 2a - 2b.

Hold down = the pump will not restart and goes OUT OF ORDER. The pump is put OUT OF SERVICE. For instructions on how to reactivate the pump, see point 3.



Controller Specific Instructions & Troubleshooting



Troubleshooting: Presflo - Fixed Speed Controller

Problems	Signals	Possible causes	Solutions
PRESFLO® will not turn on	POWER ● STATUS ●	No power	Check the electrical connections
The pump will not start when a tap is turned on	POWER ● STATUS ●	PRESFLO® model with an inadequate start-up pressure (Pm) for the chosen application	Relocate PRESFLO® to another position Install a model with a higher start-up pressure (Pm)
	POWER ● STATUS ●	Faulty electrical connections or pump out of service	Check the electrical connections and that the pump is working
	POWER ☼ ● ● ● ● ● STATUS ●	PRESFLO® "OUT OF SERVICE"	Reset PRESFLO® (See Operation, point 3).
	POWER ☼ ● ● ● ● ● STATUS ☼ ● ●	PRESFLO® in temporary shut down due to "DRY RUNNING" due to lack of water Maximum pump pressure is insufficient	Wait for the automatic restart or press START to restart manually (See Operation, point 4a) Replace the pump with one with more suitable characteristics Install a model with a lower start-up pressure (Pm)
	POWER ☼ ● ● ● ● ● STATUS ☼ ● ● ●	PRESFLO® in temporary shut down due to "FREQUENT START-UP"	Wait for the automatic restart or press START to restart manually (See Operation, point 4b). Remove any cause of leakage from system or install an expansion tank
	The pump delivers no or low pressure	POWER ● STATUS ●	Filters or pipes may be partly blocked
		PRESFLO®'s valve will not open completely	Check that the valve is not blocked by any foreign objects and clean if necessary
The pumps stops and starts repeatedly	POWER ● STATUS ● POWER ● STATUS ●	Leaks within the system (less than the shut-off flow rate Qa)	Check the hydraulic connections and repair any leaks. If a leak cannot be repaired, install an expansion tank
The pump will not stop	POWER ● STATUS ●	The flow rate is higher than the shut-off flow rate (Qa)	Make sure that all taps are turned off and that there are no leaks within the system
		PRESFLO®'s check valve will not close or is damaged	Check that the valve is not blocked by any foreign objects and clean if necessary

On ● Off ● Flashing ☼ ● ● ● ● ●

Controller Specific Instructions & Troubleshooting



Operation: Presflo Multi - Fixed Speed Controller

1 No power supply

POWER ON
 PUMP ON

- PRESFLO® is switched off.

Press briefly or hold down = nothing happens

Power is restored = PRESFLO® resumes NORMAL SERVICE & starts the pump (if necessary).

STOP button icon

3 Out of service

POWER ON (flashing)
 PUMP ON

- The pump has been stopped manually.

The pump will remain inactive until a new command is given.

Press briefly = nothing happens

Hold down = the pump resumes NORMAL SERVICE. See points 2a - 2b.

STOP button icon

2a NORMAL SERVICE: the pump is inactive.

POWER ON
 PUMP ON

- The system is pressurised. All taps are turned off. There is no demand for water. PRESFLO® detects an assembly pressure higher than that of the start-up pressure (Pm) and no flow.

Press briefly = the pump is started manually and runs for a few seconds before stopping again.

Hold down = the pump is put OUT OF SERVICE.

For instructions on how to reactivate the pump, see point 3.

A tap is turned on = as soon as the pressure falls below the start-up pressure (Pm), the pump is started.

STOP button icon

4a ERROR: stopped temporarily due to DRY RUNNING

POWER ON (flashing)
 PUMP ON

- PRESFLO® has detected that the pump is dry running and has therefore stopped it TEMPORARILY.

Press briefly = the pump is started and manually resumes NORMAL SERVICE. See points 2a - 2b.

Hold down = the pump is put OUT OF SERVICE. For instructions on how to reactivate the pump, see point 3.

STOP button icon

2b NORMAL SERVICE: the pump is running

POWER ON
 PUMP ON

- The assembly requires water. One or more taps are turned on. PRESFLO® detects a flow; the assembly pressure is normally higher than the START-UP pressure, but it may also be lower.

Press briefly or hold down = the pump is stopped and put OUT OF SERVICE. For instructions on how to reactivate the pump, see point 3.

The taps are turned off = if there is no flow for a few seconds, the pump is stopped.

STOP button icon

4b ERROR: temporary shut down due to FREQUENT START UP

POWER ON (flashing)
 PUMP ON

- PRESFLO® has detected that the pump is starting-up too often and has therefore stopped it TEMPORARILY.

Press briefly = the pump is started and manually resumes NORMAL SERVICE. See points 2a - 2b.

Hold down = the pump will not restart and goes OUT OF ORDER. The pump is put OUT OF SERVICE. For instructions on how to reactivate the pump, see point 3.

STOP button icon

2c NORMAL SERVICE: pump during shutdown

POWER ON
 PUMP ON (flashing)

- The system has just ceased to require water. All taps are closed. The pump is still in operation. The system is pressurised. PRESFLO® detects a system pressure higher than the start-up pressure (Pm) and no flow.

Press briefly or hold down = the pump is stopped and put in STAND-BY. To reset see point 3. If the absence of flow lasts for a few seconds the pump is stopped.

STOP button icon

4c ERROR: stop due to overload

POWER ON (flashing)
 PUMP ON

- PRESFLO® has detected a current exceeding the max. allowed and has stopped the pump.

Press briefly = the pump is started and manually resumes NORMAL SERVICE. See points 2a - 2b.

Hold down = the pump is put OUT OF SERVICE. For instructions on how to reactivate the pump, see point 3.

STOP button icon

Controller Specific Instructions & Troubleshooting



Trouble Shooting: Presflo Multi - Fixed Speed Controller

Problems	Signals	Possible causes	Solutions
PRESFLO® will not turn on	POWER ON PUMP ON	No power	Check the electrical connections
The pump will not start when a tap is turned on	POWER ON PUMP ON	PRESFLO® model with an inadequate start-up pressure (Pm) for the chosen application	Relocate PRESFLO® to another position Install a model with a higher start-up pressure (Pm)
	POWER ON PUMP ON	Faulty electrical connections or pump out of service	Check the electrical connections and that the pump is working
	POWER ON PUMP ON	PRESFLO® "STAND-BY"	Reset PRESFLO® (See Operation, point 3).
	POWER ON PUMP ON	PRESFLO® in temporary shut down due to "DRY RUNNING" due to lack of water	Wait for the automatic restart or press START to restart manually (See Operation, point 4a)
	POWER ON PUMP ON	Maximum pump pressure is insufficient	Replace the pump with one with more suitable characteristics Install a model with a lower start-up pressure (Pm)
	POWER ON PUMP ON	PRESFLO® in temporary shut down due to "FREQUENT START-UP"	Wait for the automatic restart or press START to restart manually (See Operation, point 4b). Remove any cause of leakage from system or install an expansion tank
	POWER ON PUMP ON	PRESFLO® stops due to "OVERCURRENT"	Check if the setting of the maximum current (Imax) is congruent with the data of the pumps' ratingplate. If after manually restarting the pump after correctly setting PRESFLO®, it again signals an anomaly, check that the motor has no mechanical or electrical problems.
The pump delivers no or low pressure	POWER ON PUMP ON	Filters or pipes may be partly blocked	Check the water pipes
	POWER ON PUMP ON	PRESFLO®'s valve will not open completely	Check that the valve is not blocked by any foreign objects and clean if necessary
The pumps stops and starts repeatedly	POWER ON PUMP ON POWER ON PUMP ON	Leaks within the system (less than the shut-off flow rate Qa)	Check the hydraulic connections and repair any leaks. If a leak cannot be repaired, install an expansion tank
The pump will not stop	POWER ON PUMP ON	The flow rate is higher than the shut-off flow rate (Qa)	Make sure that all taps are turned off and that there are no leaks within the system
	POWER ON PUMP ON	PRESFLO®'s check valve will not close or is damaged	Check that the valve is not blocked by any foreign objects and clean if necessary

On Off Flashing

Controller Specific Instructions & Troubleshooting



Starting up: Steadypres - Variable Speed Controller

- When STEADYPRES is powered, it will be:
 - IN SERVICE if at time of last switch off it was IN SERVICE.
 - OUT OF SERVICE if at time of last switch off it was OUT OF SERVICE.
- To start STEADYPRES, press the **ON/OFF**  key on the control panel and press it again to place it out of service.



Set pressure quick adjustment: Steadypres - Powertank Variable Speed Control

The WORKING PRESSURE is displayed via the GREEN LEDs that light up on the control panel, and which ranges from a minimum of 1 bar to a maximum of 9 bar.

- A fixed GREEN LED indicates a full 1 bar of pressure 
- A flashing GREEN LED indicates a 0.5 bar of pressure 

To adjust the WORKING PRESSURE:

- Press the **+** key to display the working pressure.
- Press the keys **+ or -** to increase or decrease the WORKING PRESSURE.
- On each press of the key **+ or -** you increase or decrease the value in steps of 0.5 bar.



In this example the pressure indicated is 3.5 bar.

Light Signals: Steadypres - Powertank Variable Speed Control

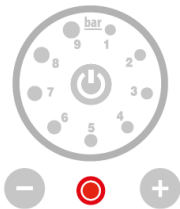

Fixed RED LED

↓
DECOMMISSIONING

STEADYPRES is live but was manually put out of service

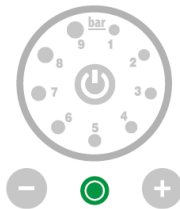

Fixed GREEN LED

↓
PUMP IN STAND-BY

STEADYPRES is in service but the pump is NOT running

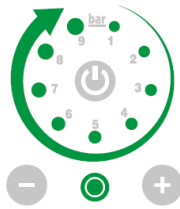

Fixed GREEN LED + GREEN LED
In continuous rotation

↓
PUMP RUNNING

STEADYPRES is running and the pump is running

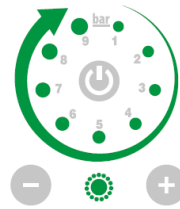

Flashing GREEN LED + GREEN LED
In continuous rotation

↓
PUMP IN STOPPAGE PHASE

STEADYPRES is running in stop phase

Controller Specific Instructions & Troubleshooting

Alarms: Steadypres - Variable Speed Controller



Problems	Signals LED	No. Green LED	Cause	Solutions
Dry running (DRY RUNNING)	 Flashing	1  Flashing	No water intake, intake obstructed, fault on pressure sensor.	Run the relevant checks.
Pressure limit maximum (NO PARTIAL RESSURE)	 Flashing	2  Flashing	The pump cannot manage to provide the pressure requested, on closure).	Check the maximum pressure of the pump and correct the Pset.
Low working pressure (NO TOTAL PRESSURE)	 Flashing	4  Flashing	The working pressure is lower than the minimum safety threshold.	Check there are no broken tubes, insert a valve that adjusts the flow.
Low voltage (LOW VOLTAGE)	 Flashing	5  Flashing	The voltage reaches peaks under the minimum use voltage.	Power the inverter with the line separate, insert a voltage stabiliser.
OFF signal from outside (EXT OFF)	 Flashing	6  Flashing	The inverter was placed out of service from remote.	Put back in service from remote.
Short circuit. (OVERCURRENT NOT MANAGEABLE)	 Flashing	1  Fixed	Short circuit or current dispersion in section that goes from the module to the motor of the pump.	Check isolation of cable and motor. Try the inverter disconnected from the motor.
Overcurrent (OVERCURRENT)	 Flashing	2  Fixed	Continuous overcurrent, with possible motor problem.	Check motor in direct operation.
Excessive module temperature	 Flashing	3  Fixed	The module does not cool correctly or is damaged.	Check the water passes in the inverter.
Pressure signal not valid	 Flashing	5  Fixed	Pressure signal wrong or missing.	Check/replace the pressure sensor.
Flow signal not valid.	 Flashing	6  Fixed	Flow signal wrong or missing.	Check/replace the flow sensor.
The pump won't stop	-	-	The valve has remained open due to foreign body.	Extract the check valve: check/clean.
The pump starts and stops continuously	-	-	The expansion tank is deflated or damaged and does not keep the circuit pressurised.	Check the expansion tank.
The keypad won't switch on	-	-	The fuse has blown.	Replace the fuse.



DECLARATION OF CONFORMITY



PLEASE KEEP THIS DOCUMENT IN A SAFE PLACE

We, Pedrollo Distribution Ltd
of Crossfield Fort
Crossfield Road Industrial Estate
Lichfield WS13 6RJ
Telephone: 01543 415 200
Fax: 01543 415900
sales@pedrollo.co.uk

in accordance with the following Directives:
Refer to page 19 for list of directives

Hereby declare that:
Equipment: Powertank Range

is in conformity with the applicable requirements of the following documents:
Refer to page 19 for list of national implementation provisions

I hereby declare that the equipment above has been designed and assembled to comply with the relevant section of the above referenced specifications. The unit complies with all applicable Essential Requirement of the Directives.

The Technical Construction File is maintained at:

Pedrollo Distribution Ltd
Crossfield Fort
Crossfield Road Industrial Estate
Lichfield WS13 6RJ
Telephone: 01543 415 200
Fax: 01543 415900
sales@pedrollo.co.uk

Signed: 
Managing Director, Pedrollo Distribution

Date: 20/01/2021

Directives and National Implementation Provisions

Pump Range	Provisions
Top Multi Top Multi-Tech NK UP	EN 60335-1
	EN60034-1
	IEC 60335-1
	IEC 60334-1
	CIE 61-150
	CIE 2-3

Controllers	
Steadypress	Directives
	2006/95/CEE Low Voltage Directive
	2002/95/CEE Dangerous substances in electromagnetic compliances(RoHS)
	2002/96/CEE e 2003/108/CEE Dangerous substances in electronic appliances (WEEE)
	2004/108/CE Electromagnetic Compatibility Directive(EMC)
	EN 5501-1 (emissions)
	Provisions
	EN 61000-3-2 (emissions)
	EN 61000-3-3 (emissions)
	EN 55014-2 (immunity)
	EN 61000-4 (immunity)
Pressflo Multi	Directives
	2006/95/CEE Low Voltage Directive
	2002/95/CEE Dangerous substances in electromagnetic compliances(RoHS)
	2002/96/CEE e 2003/108/CEE Dangerous substances in electronic appliances (WEEE)
	2004/108/CE Electromagnetic Compatibility Directive(EMC)
	Provisions
	EN 61000 6-3

Tank Type	Provisions
Holding Tank	BS 6920-1:2000

Pipe Type	Provisions
MDPE Blue Pipe	AS/NZS 4020
	BS EN 12201-2
	BS EN 1717:2000
	BS EN 12201

Valve Type	Provisions
Check Valve	EN 1717:2000
Flow Valve	BS 1212/1
Fill Valve	WRAS Approved 1203001

Fitting Type	Provisions
Nylon Fittings	EN 60335-1

Sealant Type	Provisions
Thread Sealant	WRAS Approved
	Certified NSF P1. sealant paste "green", no risk phrases, blank MSDS

Powertank Range

Model Type	Volume [LTR]	Length [MM]	Width [MM]	Height [MM]	Inlet [Inch]	Outlet [Inch]	Over-flow	Drain off [Inch]	Weight (Empty Tank) (kg)
POWERTANK 10ltr CAT 5 - Fixed Speed	10	500	300	670	¼" BSP	1" BSP	40mm	-	14
POWERTANK 125ltr Compact - Fixed Speed	125	560	490	850	½" BSP	1" BSP	40mm	1" BSP	27
POWERTANK 125ltr Compact - Variable Speed	125	560	490	870	½" BSP	1" BSP	40mm	1" BSP	33
POWERTANK 200ltr DG Blu - Variable Speed	200	570	512	1211	½" BSP	1" BSP	40mm	1" BSP	34
POWERTANK 200ltr Slimline - Fixed Speed	200	584	584	1190	½" BSP	1" BSP	40mm	1" BSP	26
POWERTANK 200ltr Slimline - Variable Speed	200	584	584	1210	½" BSP	1" BSP	40mm	1" BSP	32
POWERTANK 350ltr Slimline - Fixed Speed	300	584	584	1656	½" BSP	1" BSP	40mm	1" BSP	29
POWERTANK 350ltr Slimline - Variable Speed	300	584	584	1676	½" BSP	1" BSP	40mm	1" BSP	35
POWERTANK 450ltr Slimline - Fixed Speed	450	584	584	2100	½" BSP	1" BSP	40mm	1" BSP	33
POWERTANK 450ltr Slimline - Variable Speed	450	584	584	2120	½" BSP	1" BSP	40mm	1" BSP	39
POWERTANK 200ltr Coffin - Fixed Speed	200	1106	475	770	½" BSP	1" BSP	40mm	1" BSP	30
POWERTANK 200ltr Coffin - Variable Speed	200	1106	475	790	½" BSP	1" BSP	40mm	1" BSP	37
POWERTANK 270ltr Coffin - Fixed Speed	270	1571	475	751	½" BSP	1" BSP	40mm	1" BSP	32
POWERTANK 270ltr Coffin - Variable Speed	270	1571	475	771	½" BSP	1" BSP	40mm	1" BSP	39
POWERTANK 340ltr Coffin - Fixed Speed	340	1571	475	980	½" BSP	1" BSP	40mm	1" BSP	34
POWERTANK 340ltr Coffin - Variable Speed	340	1571	475	1000	½" BSP	1" BSP	40mm	1" BSP	40
POWERTANK 450ltr Coffin - Fixed Speed	450	1765	580	846	½" BSP	1" BSP	40mm	1" BSP	36
POWERTANK 450ltr Coffin - Variable Speed	450	1765	580	866	½" BSP	1" BSP	40mm	1" BSP	42
POWERTANK 300ltr Rectangular - Fixed Speed	300	1045	665	940	½" BSP	1" BSP	40mm	1" BSP	34
POWERTANK 300ltr Rectangular - Variable Speed	300	1045	665	960	½" BSP	1" BSP	40mm	1" BSP	40
POWERTANK 500ltr Rectangular - Fixed Speed	500	1190	727	1030	½" BSP	1" BSP	40mm	1" BSP	39
POWERTANK 500ltr Rectangular - Variable Speed	500	1190	727	1050	½" BSP	1" BSP	40mm	1" BSP	45
POWERTANK 500ltr Rectangular - Variable Speed - Twin Pump	500	1190	727	1050	½" BSP	1" BSP	40mm	1" BSP	59
POWERTANK 500ltr Utility - Fixed Speed	500	760	760	1393	½" BSP	1" BSP	40mm	1" BSP	34
POWERTANK 500ltr Utility - Variable Speed	500	760	760	1413	½" BSP	1" BSP	40mm	1" BSP	40
POWERTANK 500ltr Utility - Variable Speed - Twin Pump	750	760	760	1413	½" BSP	1" BSP	40mm	1" BSP	52

Model Type	Volume [LTR]	Length [MM]	Width [MM]	Height [MM]	Inlet [Inch]	Outlet [Inch]	Over-flow	Drain off [Inch]	Weight (Empty Tank) (kg)
POWERTANK 750ltr Utility - Fixed Speed	750	760	760	213	½" BSP	1" BSP	40mm	1" BSP	49
POWERTANK 750ltr Utility - Variable Speed	750	760	760	2133	½" BSP	1" BSP	40mm	1" BSP	55
POWERTANK 750ltr Utility - Variable Speed - Twin Pump	750	760	760	2133	½" BSP	1" BSP	40mm	1" BSP	69
POWERTANK 650ltr Utility - Fixed Speed	650	1083	669	1283	½" BSP	1" BSP	40mm	1" BSP	54
POWERTANK 650ltr Utility - Variable Speed	650	1083	669	1303	½" BSP	1" BSP	40mm	1" BSP	60
POWERTANK 1000ltr Utility - Fixed speed	1000	1688	563	1640	½" BSP	1" BSP	40mm	1" BSP	74
POWERTANK 1000ltr Utility - Variable Speed	1000	1688	563	1660	½" BSP	1" BSP	40mm	1" BSP	80
POWERTANK 1000ltr Utility - Variable Speed - Twin Pump	1000	1688	563	1660	½" BSP	1" BSP	40mm	1" BSP	96
POWERTANK 250ltr Bunded - Fixed Speed	250	760	760	1478	½" BSP	1" BSP	40mm	1" BSP	49
POWERTANK 250ltr Bunded - Variable Speed	250	760	760	1498	½" BSP	1" BSP	40mm	1" BSP	55
POWERTANK 650ltr Bunded - Fixed Speed	650	752	1200	1174	½" BSP	1" BSP	40mm	1" BSP	94
POWERTANK 650ltr Bunded - Variable Speed	650	752	1200	1194	½" BSP	1" BSP	40mm	1" BSP	100

Powertank Industrial Range

Model Type	Volume [LTR]	Length [MM]	Width [MM]	Height [MM]	Inlet [Inch]	Outlet [Inch]	Overflow	Warning pipe [Inch]
POWERTANK Industrial 500ltr - Variable Speed	500	1180	680	1040	¾" BSP	1" BSP -Single 2" BSP - Twin/ Triple	40mm	¾" BSP
POWERTANK Industrial 1000ltr - Variable Speed	1000	1180	1180	1095	¾" BSP	1" BSP -Single 2" BSP - Twin/ Triple	40mm	¾" BSP
POWERTANK Industrial 1500ltr - Variable Speed	1500	1705	1205	1095	¾" BSP	1" BSP -Single 2" BSP - Twin/ Triple	40mm	¾" BSP
POWERTANK Industrial 2000ltr - Variable Speed	2000	2205	1205	1095	¾" BSP	1" BSP -Single 2" BSP - Twin/ Triple	40mm	¾" BSP
POWERTANK Industrial 2500ltr - Variable Speed	2500	2205	1265	1345	¾" BSP	1" BSP -Single 2" BSP - Twin/ Triple	40mm	¾" BSP
POWERTANK Industrial 3000ltr - Variable Speed	3000	2205	1205	1595	¾" BSP	1" BSP -Single 2" BSP - Twin/ Triple	40mm	¾" BSP
POWERTANK Industrial 4000ltr - Variable Speed	4000	2195	2195	1095	¾" BSP	1" BSP -Single 2" BSP - Twin/ Triple	40mm	¾" BSP
POWERTANK Industrial 5000ltr - Variable Speed	5000	2695	2195	1095	¾" BSP	1" BSP -Single 2" BSP - Twin/ Triple	40mm	¾" BSP

- Industrial dimensions for tank only

Powertank Commissioning Checklist



INSTALLER DETAILS

Installer Name:	
Email:	
Mobile No:	

PROJECT DETAILS

Construction Co:	
Project ID:	
Engineer:	
Mobile No:	

CLIENTS DETAILS

Name:	
Address:	
Email:	
Mobile No:	

PURCHASE DETAILS

Place of Purchase:	
Plumber/Installer:	
Email:	
Mobile No:	

TANK DETAILS



Size of Tank (L):	<input type="checkbox"/> 10L	<input type="checkbox"/> 125L	<input type="checkbox"/> 200L	<input type="checkbox"/> 300L
	<input type="checkbox"/> 340L	<input type="checkbox"/> 350L	<input type="checkbox"/> 450L	<input type="checkbox"/> 500L
	<input type="checkbox"/> 650L	<input type="checkbox"/> 750L	<input type="checkbox"/> 1000L	<input type="checkbox"/> 1500L
	<input type="checkbox"/> 2000L	<input type="checkbox"/> 2500L	<input type="checkbox"/> 3000L	<input type="checkbox"/> 4000L
	<input type="checkbox"/> 5000L	<input type="checkbox"/> Other		

Bunded Option:	<input type="checkbox"/> 250L	<input type="checkbox"/> 650L
Tank Serial Number*:		
Build Ref*:		
Date Installed:		
Commission Date:		
System type:	<input type="checkbox"/> Fixed Speed <input type="checkbox"/> Variable Speed <input type="checkbox"/> Variable Plus <input type="checkbox"/> Variable Twin <input type="checkbox"/> Variable Triple	

Build reference Number*

Tank Serial Number*



200ltr, 270ltr, 345ltr & 450ltr

1. Ball cock
2. Isolation valve
3. Powertank overflow
4. Tundish
5. Powertank drain off
6. Drip tray
7. Separate drip tray overflow
8. Removable lid with pump & controller inbuilt

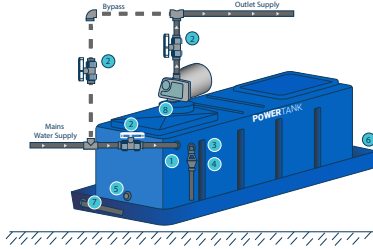

* The use of a drip tray and insulation jacket are recommended with every installation

200ltr, 350ltr, 500ltr & 750ltr

1. Ball cock
2. Isolation valve
3. Powertank overflow
4. Tundish
5. Powertank drain off
6. Drip tray
7. Drip tray overflow

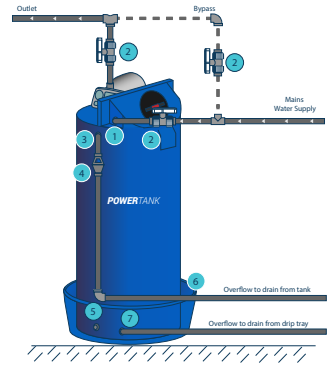

* The use of a drip tray and insulation jacket are recommended with every installation

INSTALLATION AND COMMISSIONING CHECKLIST

ITEM	STATUS		COMMENT
Visual inspection of Powertank for any defects	<input type="checkbox"/>	Yes <input type="checkbox"/> No	
Is a Powertank installation label on tank?	<input type="checkbox"/>	Yes <input type="checkbox"/> No	
Is the Powertank positioned in a safe location?	<input type="checkbox"/>	Yes <input type="checkbox"/> No	
Is the Powertank installed away from direct sunlight?	<input type="checkbox"/>	Yes <input type="checkbox"/> No	
Is there a bypass unit fitted around system?	<input type="checkbox"/>	Yes <input type="checkbox"/> No	
Is there a shut off valve fitted on inlet of tank?	<input type="checkbox"/>	Yes <input type="checkbox"/> No	
Is a drip tray fitted with correct size overflow?	<input type="checkbox"/>	Yes <input type="checkbox"/> No	
Is an insulation jacket fitted?	<input type="checkbox"/>	Yes <input type="checkbox"/> No	
Has the correct overflow pipe been selected for Powertank?	<input type="checkbox"/>	Yes <input type="checkbox"/> No	
Has the correct overflow pipework been selected for drip tray?	<input type="checkbox"/>	Yes <input type="checkbox"/> No	
Have overflows been piped separately, without any sharp edges which could cause restriction?	<input type="checkbox"/>	Yes <input type="checkbox"/> No	
Has incoming water pressure been tested and has the correct ballcock been selected and tested?	<input type="checkbox"/>	Yes <input type="checkbox"/> No	
Has the Powertank been fitted in a ventilated area?	<input type="checkbox"/>	Yes <input type="checkbox"/> No	
Has the unit's power supply to electrical supply been connected in accordance with current regulations and by a qualified, trained person?	<input type="checkbox"/>	Yes <input type="checkbox"/> No	
Has a full test of overflow pipes been done?	<input type="checkbox"/>	Yes <input type="checkbox"/> No	
Has the system been correctly installed and fully tested?	<input type="checkbox"/>	Yes <input type="checkbox"/> No	
Any pressure reducing valves fitted on line?	<input type="checkbox"/>	Yes <input type="checkbox"/> No	
If yes, has the control unit been adjusted to the correct parameters for operation?	<input type="checkbox"/>	Yes <input type="checkbox"/> No	
Incoming water pressure to Powertank	Bar	<input type="text"/>	
Powertank cut in pressure	Bar	<input type="text"/>	
Powertank close valve pressure	Bar	<input type="text"/>	

Print Name (Installer):	Signed:	Position:	Date:
Print Name (Engineer):	Signed:	Position:	Date:

Pedrollo Distribution Ltd
Crossfield Fort
Crossfield Road Industrial Estate
Lichfield
WS13 6RJ

t: 01543 415200

e: sales@pedrollo.co.uk

w: pedrollodistribution.co.uk

powertank.co.uk



**UK
CA**

**MADE IN
BRITAIN**