

CLARKE®



JUMPSTART

MODEL NO: JS4000

PART NO: 6240030

OPERATING & MAINTENANCE INSTRUCTIONS



ORIGINAL INSTRUCTIONS

GC0420 -rev 7

INTRODUCTION

Thank you for purchasing this CLARKE Jump-start.

Before attempting to use this product, please read this manual thoroughly and follow the instructions carefully. In doing so you will ensure the safety of yourself and that of others around you, and you can look forward to your purchase giving you long and satisfactory service.

Please keep these instructions in a safe place for future reference.

SPECIFICATIONS

Item	Specification
Weight	17 kg
Dimensions (L x H x D) mm	345 x 390 x 190
Insulation Class	Class II
Max Output Current	Starting 1100A Peak 2200A
Battery Type	Sealed re-chargeable lead-acid 12V/40AH
Lighter Socket output	12V DC /1.9A for 20 hours
Estimated engine starting capacity	Up to 4.0 litres (diesel) Up to 6.0 litres (petrol)
Working lamp	Screw-in 12V/0.3Amp

Please note that the details and specifications contained herein, are correct at the time of going to print. However, CLARKE International reserve the right to change specifications at any time without prior notice.

GENERAL SAFETY RULES

1. Always ensure when jump-starting that there is air circulating around the machine.
2. Never allow the negative and positive leads on this unit, to touch each other or to touch the same metal object.
3. Although the jump-start is water resistant and may be used outdoors, DO NOT leave it exposed to the elements. Avoid direct sunlight, direct heat, rain/moisture etc.
4. The JS4000 jump-start is designed for use with 12V systems.
5. Do not operate the jump-start if any of the cables are damaged. Consult your CLARKE dealer for repair or replacement of the parts.
6. Do not operate the jump-start if the case is damaged. Consult your CLARKE dealer or a qualified person for inspection and repair.
7. Ensure the vehicle battery posts and battery clamps are perfectly clean before use.
8. When connecting the jump-start leads to a battery, ensure the ON/OFF switch is OFF, and ALWAYS connect the RED, (positive '+') output conductor to the UNEARTHED (+) battery terminal FIRST, then connect the BLACK, (negative) conductor to a suitable earthing point on the chassis, well away from any fuel lines.
9. To prevent the battery overheating and consequent damage, do not exceed our recommendations for the duration of jump starting.
10. Always wear suitable protective clothing and eye protection when working with lead-acid batteries.
11. The jump-start is NOT designed to be used as a replacement for a vehicle battery.
12. DO NOT attempt to BOOST CHARGE the jump-start's sealed battery.
13. Never allow the battery to become completely discharged.
14. Never jump-start the engine whilst the jump-start is being charged.
15. Never allow the cables to become wrapped around the operator or any other person.
16. Never attempt any repairs yourself. If you have a problem with the jump-start contact your local CLARKE dealer.
17. Always keep your body and clothing dry. Never work in damp area without adequate insulation against electric shock.

18. Always store the jump-starter out of reach of children.
19. Always wear safety glasses when working with lead acid batteries.
20. If splashed by battery acid, immediately flush the area of the splash with clean water. If a burning sensation is felt or any blistering occurs, seek medical help.
21. If acid comes into contact with the eyes, flush the eyes with clean water continuously and seek medical help.



WARNING: ALL LEAD ACID BATTERIES GENERATE HYDROGEN GAS DURING NORMAL OPERATION. THIS PROCESS INCREASES DURING A PERIOD OF RAPID DISCHARGE, SUCH AS WHEN USING FOR JUMP - STARTING.

WARNING: HYDROGEN GAS AND BATTERY ACID (SULPHURIC ACID) CAN BE: EXPLOSIVE, CORROSIVE TO SKIN, EYES AND HAIR, DAMAGING TO CLOTHING AND METALS, FLAMMABLE, POISONOUS TO BREATHE

ENVIRONMENTAL RECYCLING POLICY



Through purchase of this product, the customer is taking on the obligation to deal with the WEEE in accordance with the WEEE regulations in relation to the treatment, recycling & recovery and environmentally sound disposal of the WEEE.

In effect, this means that this product must not be disposed of with general household waste. It must be disposed of according to the laws governing Waste Electrical and Electronic Equipment (WEEE) at a recognised disposal facility.

ELECTRICAL SYMBOLS DISPLAYED

The meanings of the safety markings and symbols which may be displayed on this product are shown below.



Class II appliance without an earth connection



Always read instructions before use



Electrical hazard due to exposed live terminals



Chemical Hazard from battery acid

ELECTRICAL CONNECTIONS

This product is provided with a 13 amp, 230 volt (50Hz), charging adaptor for connection to a standard, domestic electrical supply. Should the plug need changing at any time, ensure that a plug of identical specification is used.



This product is of double insulated design. No earth conductor is provided.

No earth conductor is provided. The two wires in the mains lead should be wired up in accordance with the following colour code:

Blue — Neutral

Brown — Live

Connect the BROWN coloured cable to the plug terminal marked a letter "L".

Connect the BLUE coloured cable to the plug terminal marked a letter "N".

If the battery charger for this appliance is fitted with a plug which is moulded on to the electric cable (i.e. non-rewireable) please note:

1. The plug must be thrown away if it is cut from the electric cable. There is a danger of electric shock if it is subsequently inserted into a socket outlet.
2. Never use the plug without the fuse cover fitted.
3. Should you wish to replace the fuse cover, ensure that the correct replacement is used (as indicated by marking or colour code).
4. Replacement fuse covers can be obtained from your local CLARKE dealer or most electrical stockists.

FUSE RATING

The fuse in the plug must be replaced with one of the same rating and this replacement must be ASTA approved to BS1362.

If in any doubt, consult a qualified electrician. DO NOT attempt any electrical repairs yourself.

COMPONENT IDENTIFICATION

The JS4000 is a rechargeable power supply which can be used to start a car in the event of a flat battery. The unit can also be used to power electrical appliances via a cigarette lighter type socket using the adaptor supplied. The unit also incorporates a built-in lamp and may be used as a stand alone light source. An audible warning will sound in the event of low battery voltage, or if the clamps are incorrectly fitted for jump starting (wrong polarity).

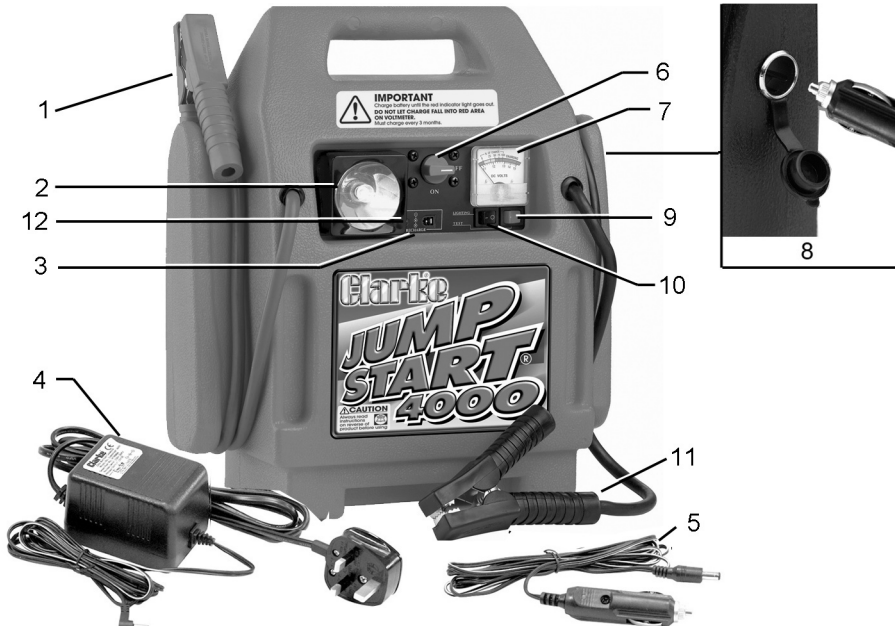

1	Positive Battery Connecting Lead to connect to positive battery terminal	7	Voltage Meter to indicate the voltage level of the units battery.
2	Lamp to provide light for roadside repairs or emergency situations.	8	Cigar Lighter Socket for use with the cigar lighter adaptor provided.
3	12 DC Socket connects the 230 Volt charger for mains charging.	9	Voltage Test Switch. Press to indicate the internal battery power level.
4	230 Volt Charger to charge the internal battery pack	10	Lamp ON/OFF Switch. Switches the lamp ON or OFF.
5	Cigar Lighter Adaptor complete with 5 Amp fuse.	11	Negative Battery Connection Lead to connect to the negative battery terminal.
6	ON/OFF Switch	12	Charging Light (red)

INITIAL BATTERY CHARGING

1. Charge your jump-start battery before using it for the first time.
2. Recharge the jump-start battery after every occasion of use if possible, and thereafter, at least every 30 days.
3. Always avoid leaving your jump-start in a discharged state.

FOLLOW THE ABOVE POINTS TO ENSURE MAXIMUM LIFE FROM THE BATTERY.

Two means of charging the battery are provided:

1. Via a 230V mains electricity supply, using the mains adaptor, as shown.
2. Via a 12V supply using the vehicle cigar lighter adapter with cable and plug provided.

NOTE: Using a 12V vehicle supply, the battery will not charge to maximum, but only to approx. 50% of its capacity.



NOTE: A 5 amp fuse is fitted into the cigarette lighter plug adaptor, accessed by unscrewing the end cap of the adaptor. Take care not to loose the spring when unscrewing this cap.

CHARGING USING THE 230V MAINS ADAPTOR

1. Plug the cable into the socket at the rear of the unit, then plug the adaptor into the mains supply and switch on.
 - The red CHARGING light on the jump-start will come on to indicate charging is in progress.
2. Continue to charge until the RED charging light changes from red to green. It is important to note that this could take several days, dependant upon the state of charge of the battery.

NOTE: Pressing the 'TEST' voltage test switch with the charger disconnected, will cause the

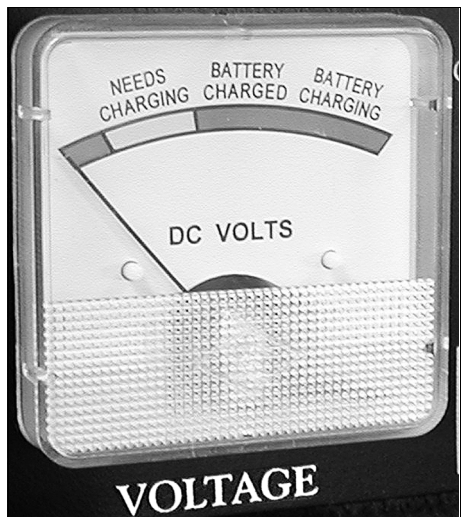

needle on the voltage meter to indicate the state of charge of the battery. Once the charger is disconnected, it will be noted that the voltage will slowly settle back. This is quite normal and should not cause alarm. When the LED extinguishes, charging will automatically stop, indicating that the battery is fully charged.

IMPORTANT: DO NOT allow the needle to enter the RED zone while pressing the test switch as this could damage the battery.

CHARGING USING THE 12V ADAPTOR

1. Plug the jack plug into the charging socket at the rear of the unit, then into the cigar lighter socket on the vehicle and start the engine. The red LED on the jump-start will indicate that charging is in progress.
2. Continue to charge until the "Internal Battery Status" gauge registers 'OK' when the 'TEST' button is pressed, **WITH THE CHARGING CURRENT DISCONNECTED**. i.e. disconnect the cigar lighter adapter from the socket on the vehicle before pressing the TEST button.

NOTE: We recommend that you use this system only when necessary, as prolonged use will reduce the life expectancy of the battery, due to the fact that this method can only charge the battery to approx. 50% of its capacity.

NOTE: For maximum battery life, we strongly recommend that you maintain the battery in a fully charged state at all times.

NOTE: If charging does not take place, check the green LED on the adapter. Ensure all connections are clean and free of grease etc.

OPERATION



WARNING: FAILURE TO FOLLOW THE INSTRUCTIONS BELOW AND THE SAFETY INSTRUCTIONS ON PAGES 3/4, MAY RESULT IN PERSONAL INJURY, DAMAGE TO THE VEHICLE, OR THE POSSIBILITY OF AN EXPLOSION

Always carry out the following preliminary checks before connecting the jump-start to the car battery:

- Ensure the vehicle ignition and ALL ancillary equipment - lighting, radio etc, is switched off.
 - Ensure the vehicle battery is rated at 12V and is not damaged in any way.
 - Ensure the battery terminals are clean and the clamps are firm and secure.
 - Remove any vehicle battery filler plugs and check the electrolyte level. If necessary, top up with distilled water.
 - Ensure the area is well ventilated.
 - Take great care not to touch the red positive (+) clamp against the black negative (-) clamp.
1. Ensure the ON/OFF switch is in the OFF position.
 2. Connect the red positive (+) clamp to the positive (+) battery terminal first. Take care the clamp does not contact any moving parts or fuel lines.
 3. Connect the black negative (-) clamp to the negative (-) battery terminal or to a suitable earthing point on the vehicle chassis ensuring the connections are firm and secure.
 - **If the polarity is incorrect, and audible warning will sound. Disconnect IMMEDIATELY and reverse the clamp connections.**
 4. Switch the Jump-start, then the vehicle ignition 'ON' and leave in this condition **FOR APPROX TWO MINUTES**. (This will provide the vehicle battery with a short 'boost' charge to allow for easier starting).
 5. Switch the ignition to 'start', for NO MORE than 6 seconds.
 - **If the engine does not start, within this time, SWITCH OFF the ignition and wait for at least 3 minutes before trying again to prevent damage to the jumpstarter due to overheating before trying again. After this cooling off period, it is safe to resume trying to start the vehicle.**
 6. Once the vehicle has started, turn the jump-start ON/OFF switch OFF.

7. Once the engine is running, disconnect the earthed clamp FIRST i.e. that connected to the chassis or Negative terminal etc, and return it to its storage position, then disconnect the Positive clamp from the battery terminal, and restore to its storage position.
8. After use, always recharge the jump-start. If the battery is allowed to remain in a discharged state, its life may be shortened.
9. Regularly check the charge level of the battery by pressing the TEST push-button on the front panel.



WARNING: IT IS POSSIBLE THAT SOME ELECTRONIC EQUIPMENT COULD BE DAMAGED BY JUMP STARTING. ALWAYS CHECK WITH THE CAR MANUFACTURER'S HANDBOOK TO DETERMINE WHAT PRECAUTIONS IF ANY SHOULD BE TAKEN.

USING AS A 12VOLT POWER SUPPLY

The unit has a cigar lighter type socket located on the side of the casing (see page 6), that allows connection via a standard DC connector to other DC electrical equipment.

WARNING: Be Aware that a fully charged 12V battery can have an output of approx. 13.5V. Consult the appliance handbook to ensure it is safe to operate from a 12V battery.

The table below indicates the approx. operating time from a fully charged battery.

ESTIMATED OPERATING PERIOD PROVIDED

Estimated Use	Electrical Appliance
30 hours	Mobile phones
21 hours	Radios, fans
12 hours	Cam-corder, VCR, Spotlight
7 hours	Electrical tools, bilge pump

MAINTENANCE

Always inspect the jump-start before use to ensure the cables are in good condition and the clamps are clean and free from corrosion. If damaged they should be replaced.

Keep the unit clean by wiping with a dry cloth. DO NOT use solvents as a cleaning agent.

GENERAL CARE

Keep the unit at HIGH or FULL CHARGE status at all times.

Always turn the jump-start OFF during storage and store in an upright position, away from direct sunlight, moisture or sources of extreme heat or cold.

NEVER attempt any repair unless you are a qualified technician. If you have a problem with the machine contact your local CLARKE dealer.

Your CLARKE jump-start has been designed to give long and trouble free service. If, however, having followed the instructions in this booklet carefully, you encounter problems, take the unit to your local CLARKE dealer.

REPLACING THE BATTERY

1. Unscrew and remove the self tapping screws securing the back cover. Lift off the cover to expose the battery and other components.
2. Lift out the battery from the battery compartment, and detach the heavy duty, and other cables, from the battery terminals.
3. Taking great care not to short across the battery terminals, connect the RED heavy duty cable, and other cable with red sheath, to the battery terminal painted RED, and the black cables to the other battery terminal.
4. Gently slide the new battery into position in its compartment, taking care not to damage the printed circuit board
5. Replace the back cover and secure with the self tapping screws.

CHANGING THE LIGHT BULB

1. Gently squeeze the sides of the lens bezel together, or very carefully use a screwdriver to disengage the clips at either side, and pull the lens and bezel out.
2. Unscrew and remove the burned out bulb and screw in a replacement.
3. Snap the lens and bezel back into place and replace the back cover.

REPLACING THE 13 AMP PLUG

Should the transformer's 13 amp plug require changing, take note that transformer is DOUBLE INSULATED, i.e. NO earth lead. The new plug must be 13amp, BS1363 approved.

Connect the Blue lead to the plug's Neutral terminal and the Brown lead to the live terminal.

IMPORTANT: The old, moulded plug MUST be thrown away. DO NOT RE-USE.

GUARANTEE

This product is guaranteed against faulty manufacture for a period of 12 months from the date of purchase. Please keep your receipt which will be required as proof of purchase.

This guarantee is invalid if the product is found to have been abused or tampered with in any way, or not used for the purpose for which it was intended.

Faulty goods should be returned to their place of purchase, no product can be returned to us without prior permission.

This guarantee does not effect your statutory rights.

DECLARATION OF CONFORMITY



Clarke[®]
INTERNATIONAL

Hemnall Street, Epping, Essex CM16 4LG

DECLARATION OF CONFORMITY

This is an important document and should be retained.

We hereby declare that this product(s) complies with the following directive(s):

2014/30/EU *Electromagnetic Compatibility directive.*

2014/35/EU *Low Voltage Equipment Directive.*

2011/65/EU *Restriction of Hazardous substances*

The following standards have been applied to the product(s):

EN 61000-6-1:2007, EN 61000-6-3:2007+A1:2011, EN 61558-1:2005+A1:2009

BS EN 61558-2-16:2009+A1:2013.

The technical documentation required to demonstrate that the product(s) meet(s) the requirement(s) of the aforementioned directive(s) has been compiled and is available for inspection by the relevant enforcement authorities.

The CE mark was first applied in: 2005

Product Description: Jumpstart.
Model number(s): JS4000
Serial / batch Number: N/A
Date of Issue: 03/11/2016

Signed:

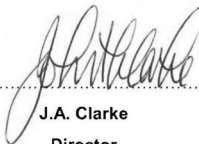
.....
J.A. Clarke
Director

COMPONENT PARTS DIAGRAM

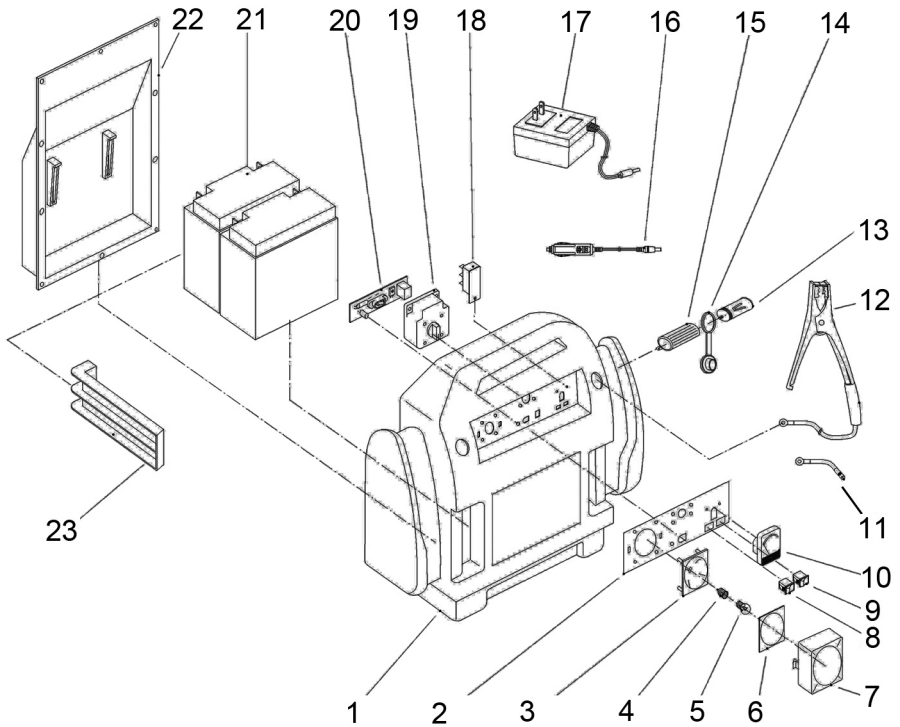

COMPONENT PARTS LIST

Spare parts are available as follows.

No	Description	Part Number
1	Housing	HT400001N
2	Label	HT400002N
3	Working Light Holder	HT400003N
4	Working Light Base	HT400017N
5	Working Light Bulb	HT400005N
6	Working Light Mirror	HT400006N
7	Working Light Cover	HT400007N
8	On/off Switch -1	HT400008N
9	On/off Switch -2	HT400009N
10	Voltage Meter	HT400010N
11	Connection Cable	HT400011N
12	F2G Booster Cable	HT400012N
13	Cigarette Cable - Negative	HT400013N
14	Protective Cover	HT400014N
15	Cigarette Cable - Positive	HT400015N
16	Cigarette Cable	HT400016N
17	Adaptor	HT400017N
18	Protector	HT400018N
19	Switch	HT400019N
20	PC Board	HT400020N
21	Battery (2 x 20Ah)	HT400021N
22	Rear Housing	HT400022N
23	Battery Retainer	HT400023N

A SELECTION FROM THE VAST RANGE OF

Clarke®

QUALITY PRODUCTS

AIR COMPRESSORS

From DIY to industrial, Plus air tools, spray guns and accessories.

GENERATORS

Prime duty or emergency standby for business, home and leisure.

POWER WASHERS

Hot and cold, electric and engine driven - we have what you need

WELDERS

Mig, Arc, Tig and Spot. From DIY to auto/industrial.

METALWORKING

Drills, grinders and saws for DIY and professional use.

WOODWORKING

Saws, sanders, lathes, mortisers and dust extraction.

HYDRAULICS

Cranes, body repair kits, transmission jacks for all types of workshop use.

WATER PUMPS

Submersible, electric and engine driven for DIY, agriculture and industry.

POWERTOOLS

Angle grinders, cordless drill sets, saws and sanders.

STARTERS/CHARGERS

All sizes for car and commercial use.



PARTS & SERVICE: 0208 988 7400

E-mail: Parts@clarkeinternational.com or Service@clarkeinternational.com

SALES: UK 01992 565333 or Export 00 44 (0)1992 565335

Clarke® INTERNATIONAL Hemnall Street, Epping, Essex CM16 4LG
www.clarkeinternational.com