

# LNTE 100-160/110/P25VCC4

## Technical data

Company name  
Contact  
Phone number  
e-mail address

Operating data					
1	Pumpe type	Single head pump	Fluid	Water, pure	
2	No. of pumps	1	Operating temperature t A	°C	4
3	Nominal flow	m <sup>3</sup> /h 0	Max / Min Operating Temperature mech. Seal	°C	120 / -25
4	Nominal head	m 0	pH-value at t A		7
5	Static head	m 0	Density at t A	kg/m <sup>3</sup>	1000
6	Inlet pressure	kPa 0	Kin. viscosity at t A	mm <sup>2</sup> /s	1.569
7	Environmental temperature	°C 20	Vapor pressure at t A	kPa	100
8	Available system NPSH	m 0	Altitude		0

Pump data					
9	Lubrication	Standard, Grease lubrication [Std]			
10	Execution	2 poles motor			
11	Design	In-Line single twin head			
12	Operating speed	2900 rpm	Stages	1	
13	Suction nozzle	DN 100 /	PN 16 /	EN1092-2	
14	Discharge nozzle	DN 100 /	PN 16 /	EN1092-2	
15	Max. casing pressure	kPa		Impeller Ø	Max. mm 177
16	Max. working pressure	kPa 242.2			designed mm 144
17	Impeller type	Radial impeller			Min. mm 144
18	Head H(Q=0)	m 25		Flow	Nominal m <sup>3</sup> /h
19	Max. shaft power	kW 9.8			Max- m <sup>3</sup> /h 157
20	Pump weight	kg			Min- m <sup>3</sup> /h 34.7
21	Total weight	kg 237.0		Head	Nominal m
					at Qmax m 15.3
					at Qmin m 24
				Shaft power	kW
				Efficiency	%
				NPSH 3%	m

Materials					
22		Pump		Shaft Seal	
23	Volute Casing	Cast Iron		Single mechanical seal, without shaft sleeve	
24	Casing Cover	Cast Iron		eMG12 - Ø28mm	BQ7EGG-WA
25	Impeller	Cast iron / ASTM Class 30		Mechanical seal diameter	28 mm
26	Stub shaft	Stainless steel / AISI 316L		1. Rotating ring	Carbon graphite resin impregnated
27	Wear ring	Stainless steel / AISI 304		2. Stationary ring	SiC, silicon carbide, sintered press. less
28	Impeller lock nut and washer	Stainless steel / AISI 304		3. Secondary seal	Ethylene propylene rubber (EPDM)
29	Impeller key	Stainless steel / AISI 316L		4. Springs	CrNiMo - Steel
30	Fill and draing plugs	Nickel-plated brass		5. Others	EPDM - WRAS
31				Gaskets of the pump	Ethylene propylene rubber (EPDM)
32					
33					
34					
35					
36					
37					
38					
39					
40					
41					

Motor data					
Electrical and dimensional data refer to IE3 motor					
42	Manufacturer	Lowara			
43	Specific design	IE3 3ph Flange Motor			
44	Type	PLM 132 B14 11 kW			
45	Rated power	11 kW	Rated current	20.2 A	
46	Nominal speed	2910 rpm	Rated voltage	400 V	
47	Frame size	132	Service factor	1	
48	Weight	kg 102.0	Degree of protection	IP55	

Remarks					
49					
50					
50					
52					

# LNTE 100-160/110/P25VCC4

## Performance curve

Company name  
Contact  
Phone number  
e-mail address

	Ø mm	Pump capacity			Pump head		Shaft power P2			Frequency	Hz	50
		Operating range Min. m³/h	Max. m³/h	η Max. m³/h	H(Q=0) m	η Max. m	P2(Q=0) kW	Max. kW	η Max. kW	Operating speed	rpm	2900
actual	144	34.7	157	112	24.7	20.4	9.82	8.77	Nominal flow	m³/h	0	
Min.	0	/	/	112	24.7	20.4	/	8.77	Nominal head	m	0	
Max.	177	/	/	163	41.2	32	/	19.6	Inlet pressure	kPa	0	
									Static head	m	0	

**Power datas referred to:**

hydr. Performance acceptance acc. To EN ISO 9906 Class Grade 3B

Water, pure [100%] ; 4°C; 1000kg/m³; 1.57mm²/s

MEI: N.A - according to Ecodesign Directive 2009/125/EC and Regulation (EU) No.547/2012

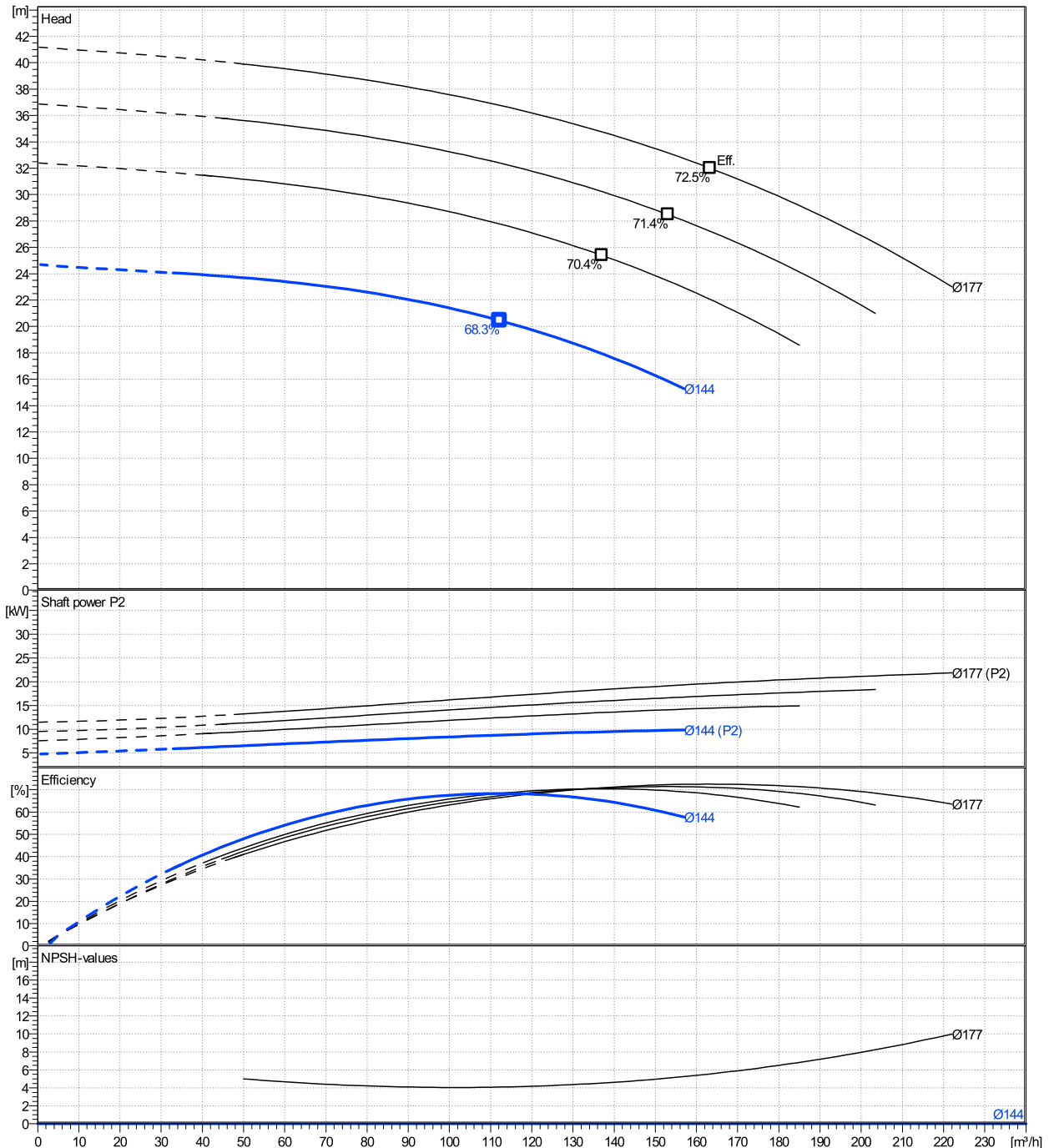

# LNTE 100-160/110/P25VCC4

## Dimensions

Company name  
Contact  
Phone number  
e-mail address

Close coupled  
2 poles motor  
PLM 132 B14 11 kW

Electrical and dimensional data refer to IE3 motor

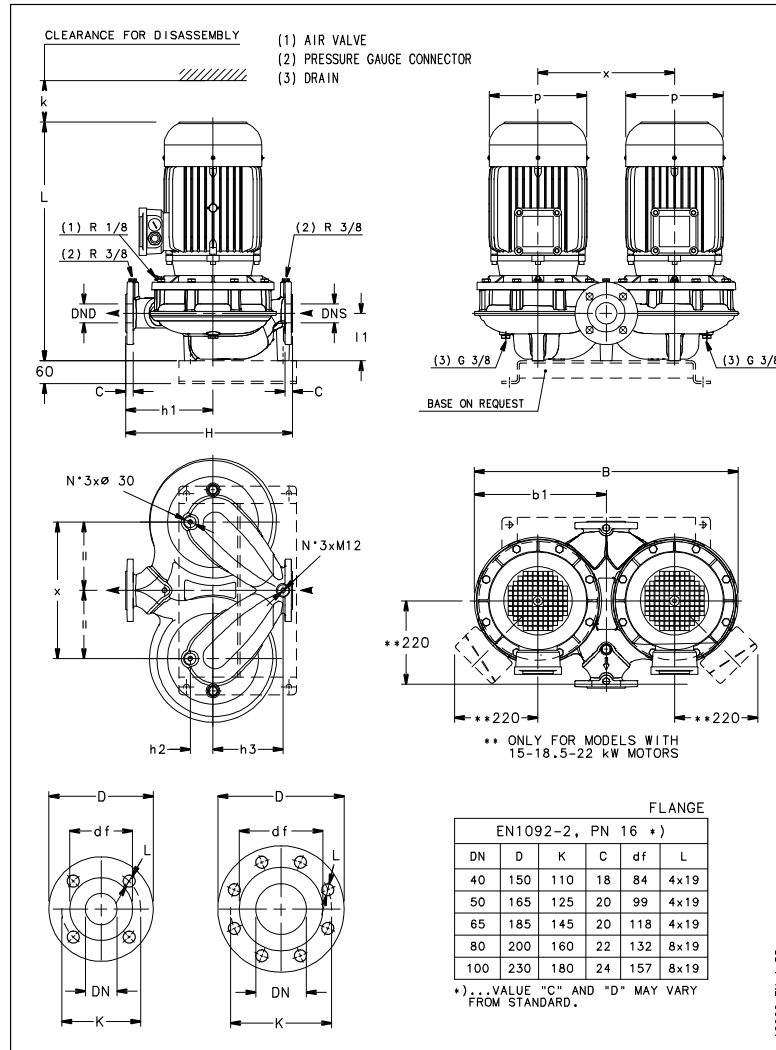

### Dimensions [ mm ]

B	748
b1	374
DND	100
DNS	100
H	500
h1	280
h2	87
h3	125
k	123
L	668
l1	158
p	256
x	410

### Weight

<b>Total weight</b>	<b>237 kg</b>
---------------------	---------------

### Connections

Suction nozzle		Discharge nozzle	
DN 100		DN 100	
PN 16		PN 16	
EN1092-2		EN1092-2	
C	24	C	24
D	230	D	230
df	157	df	157
DN	100	DN	100
K	180	K	180
L	8 x 19	L	8 x 19

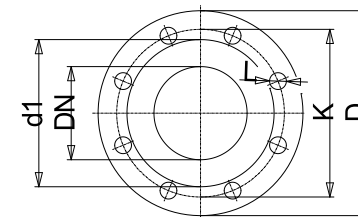

Value C, D may vary from Standard

### Dimensions and weight without obligation

Project Xylect-20969550  
Block LNTE 100-160/220/P25VCC4

Created by  
Created on 8/8/2023

Last update 8/8/2023