

LNTE 50-200/92/P25VCS4

Technical data

Company name
Contact
Phone number
e-mail address

Operating data					
1	Pumpe type	Single head pump		Fluid	Water, pure
2	No. of pumps	1		Operating temperature t A	°C 4
3	Nominal flow	m ³ /h	0	Max / Min Operating Temperature mech. Seal	°C 120 / -25
4	Nominal head	m	0	pH-value at t A	7
5	Static head	m	0	Density at t A	kg/m ³ 1000
6	Inlet pressure	kPa	0	Kin. viscosity at t A	mm ² /s 1.569
7	Environmental temperature	°C	20	Vapor pressure at t A	kPa 100
8	Available system NPSH	m	0	Altitude	0

Pump data					
9	Lubrication	Standard, Grease lubrication [Std]			
10	Execution	2 poles motor			
11	Design	In-Line single twin head			
12	Operating speed	2900 rpm	Stages	1	
13	Suction nozzle	DN 50 /	PN 16 /	EN1092-2	
14	Discharge nozzle	DN 50 /	PN 16 /	EN1092-2	
15	Max. casing pressure	kPa		Impeller Ø	Max. mm 199
16	Max. working pressure	kPa	470		designed mm 189
17	Impeller type	Radial impeller			Min. mm 165
18	Head H(Q=0)	m	48	Flow	Nominal m ³ /h
19	Max. shaft power	kW	9.1		Max- m ³ /h 60
20	Pump weight	kg			Min- m ³ /h 13.9
21	Total weight	kg	203.0	Head	Nominal m
					at Qmax m 31.2
				at Qmin m 48.6	
				Shaft power	kW
				Efficiency	%
				NPSH 3%	m

Materials					
22		Pump		Shaft Seal	
23	Volute Casing	Cast Iron		Single mechanical seal, without shaft sleeve	
24	Casing Cover	Cast Iron		eMG12 - Ø22mm	BQ7EGG-WA
25	Impeller	Stainless steel / AISI 304		Mechanical seal diameter	22 mm
26	Stub shaft	Stainless steel / AISI 316L		1. Rotating ring	Carbon graphite resin impregnated
27	Wear ring	Stainless steel / AISI 304		2. Stationary ring	SiC, silicon carbide, sintered press. less
28	Impeller lock nut and washer	Stainless steel / AISI 304		3. Secondary seal	Ethylene propylene rubber (EPDM)
29	Impeller key	Stainless steel / AISI 316L		4. Springs	CrNiMo - Steel
30	Fill and draing plugs	Nickel-plated brass		5. Others	EPDM - WRAS
31				Gaskets of the pump	Ethylene propylene rubber (EPDM)
32					
33					
34					
35					
36					
37					
38					
39					
40					
41					

Motor data					
Electrical and dimensional data refer to IE3 motor					
42	Manufacturer	Lowara			
43	Specific design	IE3 3ph Flange Motor			
44	Type	PLM 132 B14 9,2 kW			
45	Rated power	9.2 kW	Rated current	17.4 A	
46	Nominal speed	2920 rpm	Rated voltage	400 V	
47	Frame size	132	Service factor	1	
48	Weight	kg 70.4	Degree of protection	IP55	

Remarks					
49					
50					
50					
52					

LNTE 50-200/92/P25VCS4

Performance curve

Company name
Contact
Phone number
e-mail address

	Ø mm	Pump capacity			Pump head		Shaft power P2			Frequency	Hz	50
		Operating range Min. m³/h	Max. m³/h	η Max. m³/h	H(Q=0) m	η Max. m	P2(Q=0) kW	Max. kW	η Max. kW	Operating speed	rpm	2900
actual	189	13.9	60	47.5	47.9	39.2	9.05	8.3	Nominal flow	m³/h	0	
Min.	0	/	/	38.5	36	29.7	/	5.31	Nominal head	m	0	
Max.	199	/	/	51.8	53.5	43.5	/	9.85	Inlet pressure	kPa	0	
									Static head	m	0	

Power datas referred to:

hydr. Performance acceptance acc. To EN ISO 9906 Class Grade 3B

Water, pure [100%] ; 4°C; 1000kg/m³; 1.57mm²/s

MEI: N.A - according to Ecodesign Directive 2009/125/EC and Regulation (EU) No.547/2012

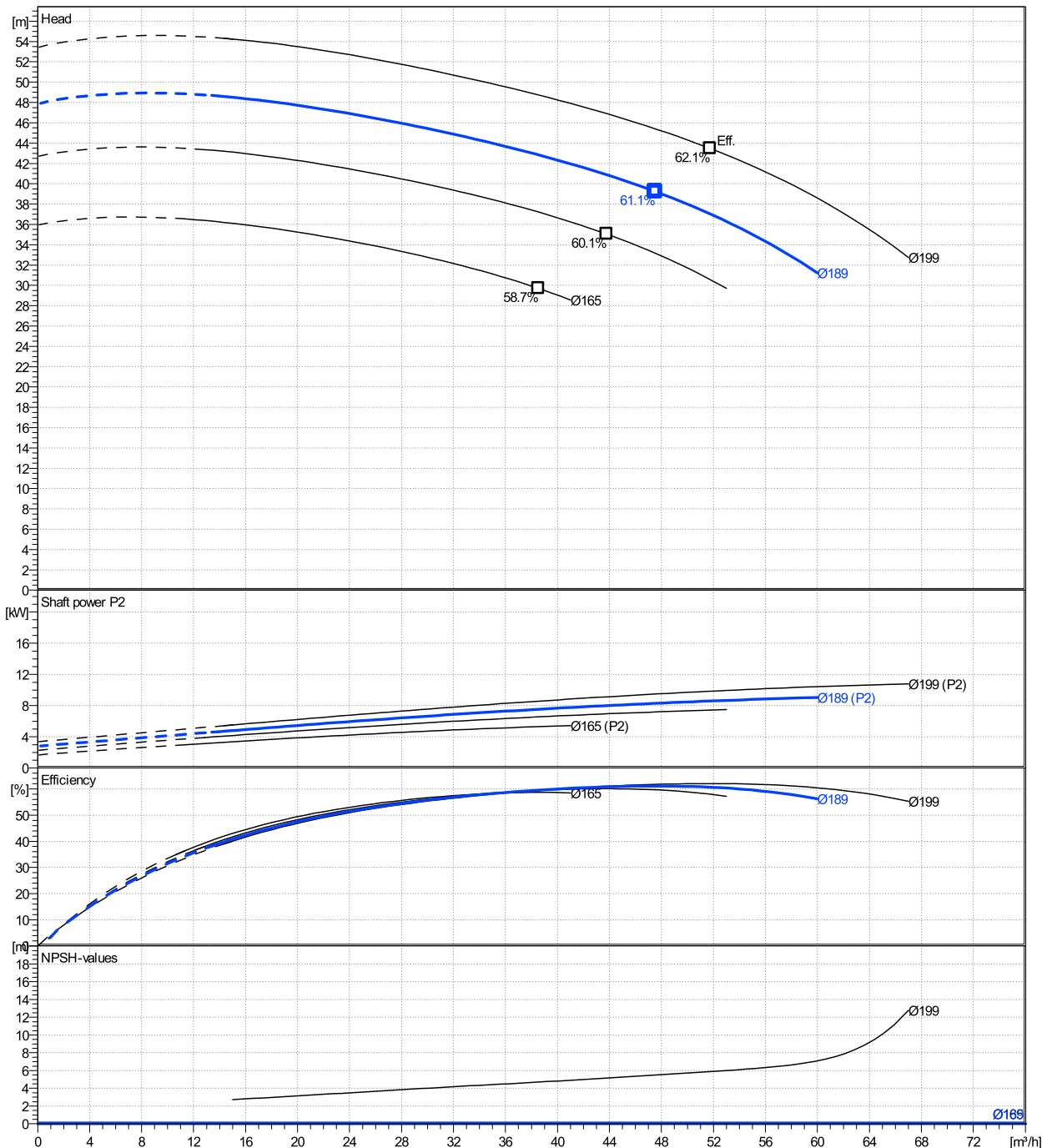

LNTE 50-200/92/P25VCS4

Dimensions

Company name
Contact
Phone number
e-mail address

Close coupled
2 poles motor
PLM 132 B14 9,2 kW

Electrical and dimensional data refer to IE3 motor

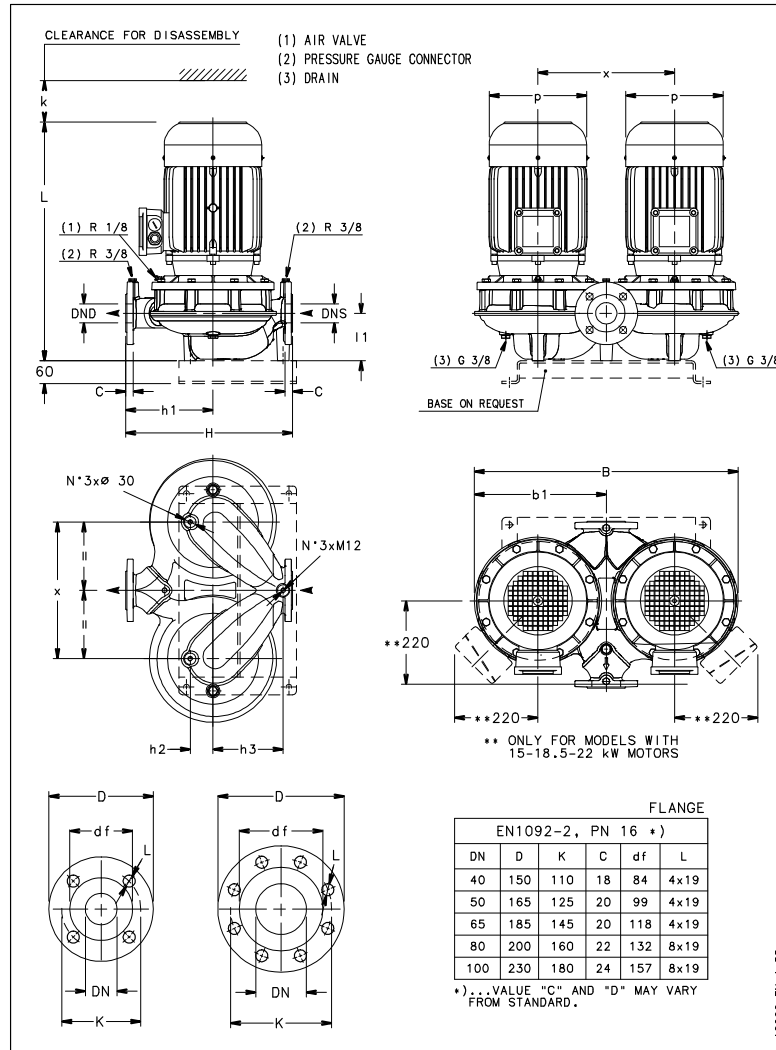

Dimensions [mm]

B	745
b1	372.5
DND	50
DNS	50
H	440
h1	230
h2	60
h3	185
k	108
L	620
l1	115
p	256
x	410

Weight

Total weight	203 kg
---------------------	---------------

Connections

Suction nozzle		Discharge nozzle	
DN 50		DN 50	
PN 16		PN 16	
EN1092-2		EN1092-2	
C	20	C	20
D	165	D	165
df	99	df	99
DN	50	DN	50
K	125	K	125
L	4 x 19	L	4 x 19

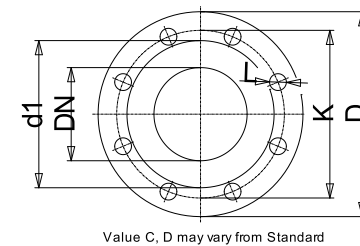

Dimensions and weight without obligation

Project	Xylect-20969277
Block	LNTE 50-200/110/P25VCS4

Created by
Created on 8/8/2023

Last update 8/8/2023