

LNTE 50-125/15/S25RCS4

Technical data

Company name
Contact
Phone number
e-mail address

Operating data					
1	Pumpe type	Single head pump		Fluid	Water, pure
2	No. of pumps	1		Operating temperature t A	°C 4
3	Nominal flow	m ³ /h	0	Max / Min Operating Temperature mech. Seal	°C 120 / -25
4	Nominal head	m	0	pH-value at t A	7
5	Static head	m	0	Density at t A	kg/m ³ 1000
6	Inlet pressure	kPa	0	Kin. viscosity at t A	mm ² /s 1.569
7	Environmental temperature	°C	20	Vapor pressure at t A	kPa 100
8	Available system NPSH	m	0	Altitude	0

Pump data					
9	Lubrication	Standard, Grease lubrication [Std]			
10	Execution	2 poles motor			
11	Design	In-Line single twin head			
12	Operating speed	2900 rpm	Stages	1	
13	Suction nozzle	DN 50	/	PN 16	/ EN1092-2
14	Discharge nozzle	DN 50	/	PN 16	/ EN1092-2
15	Max. casing pressure	kPa			
16	Max. working pressure	kPa	134.7		
17	Impeller type	Radial impeller			
18	Head H(Q=0)	m	14		
19	Max. shaft power	kW	1.5		
20	Pump weight	kg			
21	Total weight	kg	74.0		

	Impeller Ø	Max.	mm	135
		designed	mm	105
		Min.	mm	105
		Nominal	m ³ /h	
	Flow	Max-	m ³ /h	37
		Min-	m ³ /h	10
		Nominal	m	
	Head	at Qmax	m	8
		at Qmin	m	13.4
	Shaft power		kW	
	Efficiency		%	
	NPSH 3%		m	

Materials					
	Pump			Shaft Seal	
22				Single mechanical seal, without shaft sleeve	
23	Volute Casing	Cast Iron		eMG12 - Ø22mm	BQ7EGG-WA
24	Casing Cover	Cast Iron		Mechanical seal diameter	22 mm
25	Impeller	Stainless steel / AISI 304		1. Rotating ring	Carbon graphite resin impregnated
26	Stub shaft	Stainless steel / AISI 316L		2. Stationary ring	SiC, silicon carbide, sintered press.less
27	Wear ring	Stainless steel / AISI 304		3. Secondary seal	Ethylene propylene rubber (EPDM)
28	Impeller lock nut and washer	Stainless steel / AISI 304		4. Springs	CrNiMo - Steel
29	Impeller key	Stainless steel / AISI 316L		5. Others	EPDM - WRAS
30	Fill and draing plugs	Nickel-plated brass		Gaskets of the pump	Ethylene propylene rubber (EPDM)
31					
32					
33					
34					
35					
36					
37					
38					
39					
40					
41					

Motor data					
42	Manufacturer	Lowara			
43	Specific design	IE3 3ph Flange Motor			
44	Type	SM 90R B14 1,5 kW			
45	Rated power	1.5 kW	Rated current	3.17 A	
46	Nominal speed	2870 rpm	Rated voltage	400 V	
47	Frame size	90R	Service factor	1	
48	Weight	kg 13.4	Degree of protection	IP55	

Remarks					
49					
50					
50					
52					

LNTE 50-125/15/S25RCS4

Performance curve

Company name
Contact
Phone number
e-mail address

	Ø mm	Pump capacity			Pump head		Shaft power P2			Frequency	Hz	50
		Operating range Min. m³/h	Max. m³/h	η Max. m³/h	H(Q=0) m	η Max. m	P2(Q=0) kW	Max. kW	η Max. kW	Operating speed	rpm	2900
actual	105	10	37	28.7	13.7	10.3	1.46	1.36		Nominal flow	m³/h	0
Min.	0	/	/	28.7	13.7	10.3	/	1.36		Nominal head	m	0
Max.	135	/	/	36.3	25.7	21.8	/	3.16		Inlet pressure	kPa	0
										Static head	m	0

Power datas referred to:

hydr. Performance acceptance acc. To EN ISO 9906 Class Grade 3B

Water, pure [100%] ; 4°C; 1000kg/m³; 1.57mm²/s

MEI: N.A - according to Ecodesign Directive 2009/125/EC and Regulation (EU) No.547/2012

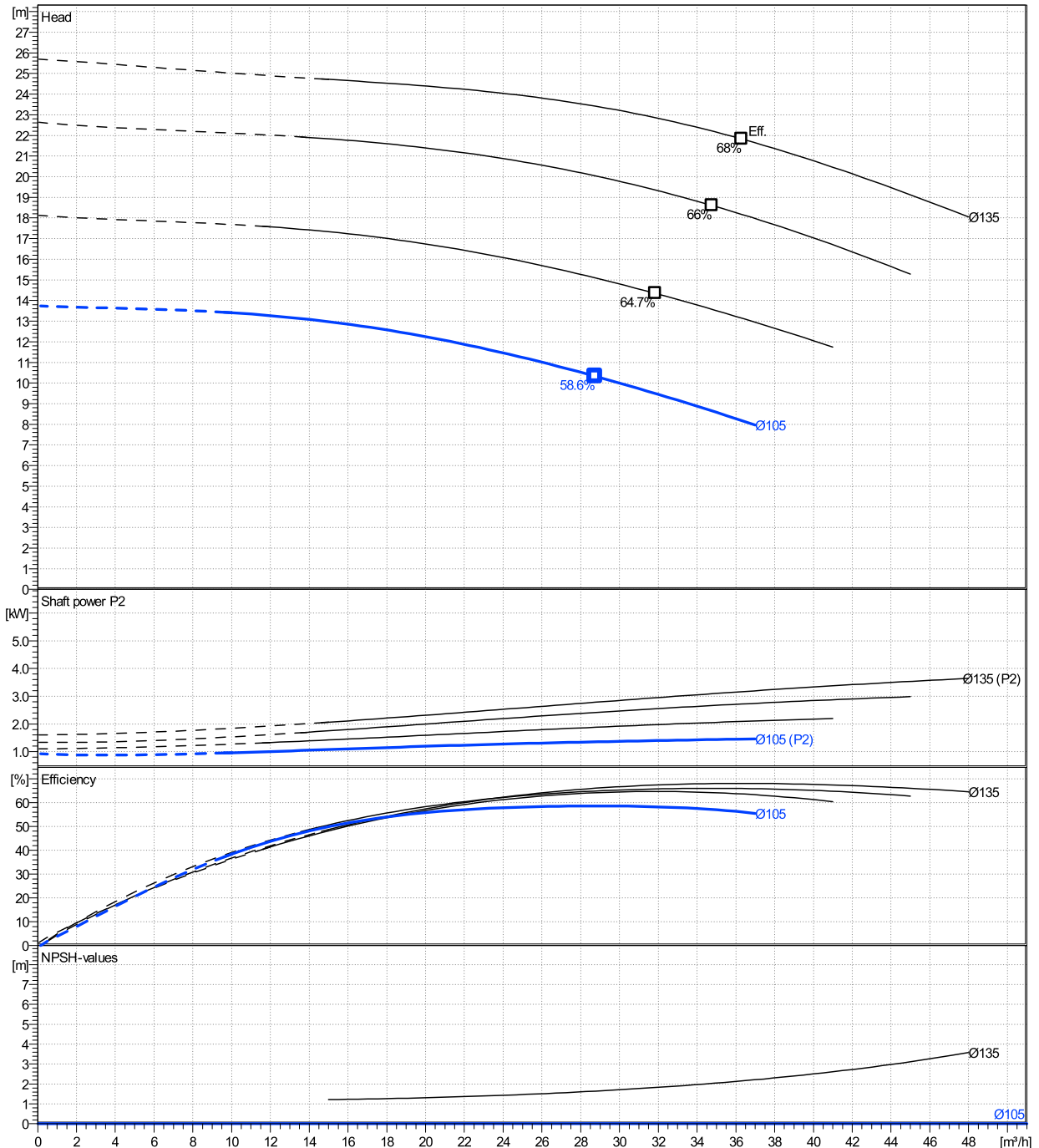

LNTE 50-125/15/S25RCS4

Dimensions

Company name
Contact
Phone number
e-mail address

Close coupled
2 poles motor
SM 90R B14 1,5 kW

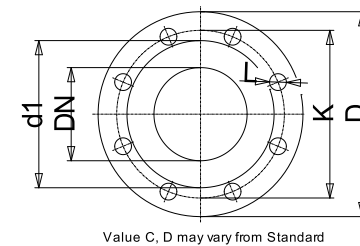
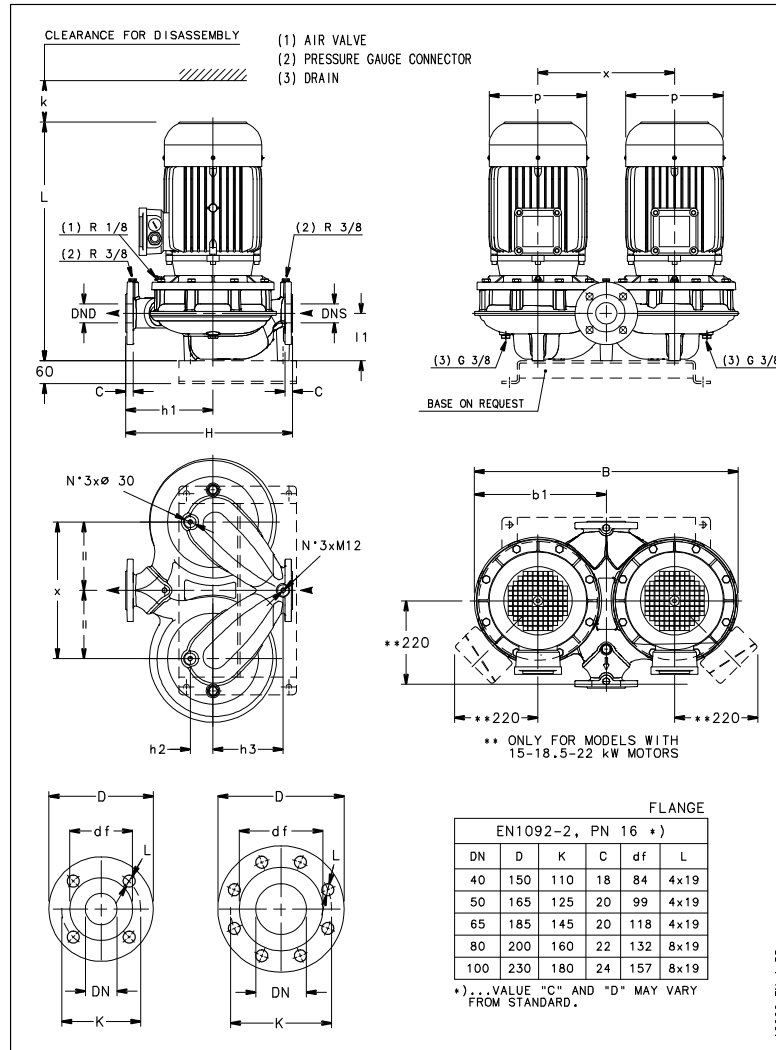

Dimensions [mm]

B	555
b1	275
DND	50
DNS	50
H	340
h1	190
h2	57
h3	120
k	96
L	479
l1	116
p	155
x	310

Weight

Total weight	74 kg
--------------	-------

Connections

Suction nozzle		Discharge nozzle	
DN 50		DN 50	
PN 16		PN 16	
EN1092-2		EN1092-2	
C	20	C	20
D	165	D	165
df	99	df	99
DN	50	DN	50
K	125	K	125
L	4 x 19	L	4 x 19

Dimensions and weight without obligation

Project	Xylect-20969224
Block	LNTE 50-125/40/P25VCS4

Created by
Created on 8/8/2023

Last update 8/8/2023