

# LNTE 40-250/75/P25VCS4

## Technical data

Company name  
Contact  
Phone number  
e-mail address

Operating data			
1	Pumpe type	Single head pump	Fluid Water, pure
2	No. of pumps	1	Operating temperature t A °C 4
3	Nominal flow	m <sup>3</sup> /h 0	Max / Min Operating Temperature mech. Seal °C 120 / -25
4	Nominal head	m 0	pH-value at t A 7
5	Static head	m 0	Density at t A kg/m <sup>3</sup> 1000
6	Inlet pressure	kPa 0	Kin. viscosity at t A mm <sup>2</sup> /s 1.569
7	Environmental temperature	°C 20	Vapor pressure at t A kPa 100
8	Available system NPSH	m 0	Altitude 0

Pump data			
9	Lubrication	Standard, Grease lubrication [Std]	
10	Execution	2 poles motor	
11	Design	In-Line single twin head	
12	Operating speed	2900 rpm	Stages 1
13	Suction nozzle	DN 40 / PN 16 / EN1092-2	Impeller Ø
14	Discharge nozzle	DN 40 / PN 16 / EN1092-2	
15	Max. casing pressure	kPa	Flow
16	Max. working pressure	kPa 584.1	
17	Impeller type	Radial impeller	
18	Head H(Q=0)	m 60	Head
19	Max. shaft power	kW 7.4	
20	Pump weight	kg	Shaft power kW
21	Total weight	kg 179.0	Efficiency %
			NPSH 3% m

Materials			
22		<b>Pump</b>	<b>Shaft Seal</b>
23	Volute Casing	Cast Iron	Single mechanical seal, without shaft sleeve
24	Casing Cover	Cast Iron	eMG12 - Ø28mm BQ7EGG-WA
25	Impeller	Stainless steel / AISI 304	Mechanical seal diameter 28 mm
26	Stub shaft	Stainless steel / AISI 316L	1. Rotating ring Carbon graphite resin impregnated
27	Wear ring	Stainless steel / AISI 304	2. Stationary ring SiC, silicon carbide, sintered press.less
28	Impeller lock nut and washer	Stainless steel / AISI 304	3. Secondary seal Ethylene propylene rubber (EPDM)
29	Impeller key	Stainless steel / AISI 316L	4. Springs CrNiMo - Steel
30	Fill and draing plugs	Nickel-plated brass	5. Others EPDM - WRAS
31			Gaskets of the pump Ethylene propylene rubber (EPDM)
32			
33			
34			
35			
36			
37			
38			
39			
40			
41			

Motor data			
Electrical and dimensional data refer to IE3 motor			
42	Manufacturer	Lowara	
43	Specific design	IE3 3ph Flange Motor	
44	Type	PLM 132 B14 7,5 kW	
45	Rated power	7.5 kW	Rated current 14.1 A
46	Nominal speed	2920 rpm	Rated voltage 400 V
47	Frame size	132	Service factor 1
48	Weight	kg 55.8	Degree of protection IP55

Remarks			
49			
50			
50			
52			

# LNTE 40-250/75/P25VCS4

## Performance curve

Company name  
Contact  
Phone number  
e-mail address

	Ø mm	Pump capacity			Pump head		Shaft power P2			Frequency	Hz	50
		Operating range Min. m³/h	Max. m³/h	η Max. m³/h	H(Q=0) m	η Max. m	P2(Q=0) kW	Max. kW	η Max. kW	Operating speed	rpm	2900
actual	214	11.3	24	24	59.5	51.9	7.39	7.39	7.39	Nominal flow	m³/h	0
Min.	0	/	/	24	59.5	51.9	/	7.39	/	Nominal head	m	0
Max.	259	/	/	40	89.7	70	/	14.8	/	Inlet pressure	kPa	0
										Static head	m	0

**Power datas referred to:**

hydr. Performance acceptance acc. To EN ISO 9906 Class Grade 3B

Water, pure [100%] ; 4°C; 1000kg/m³; 1.57mm²/s

MEI: N.A. - according to Ecodesign Directive 2009/125/EC and Regulation (EU) No.547/2012

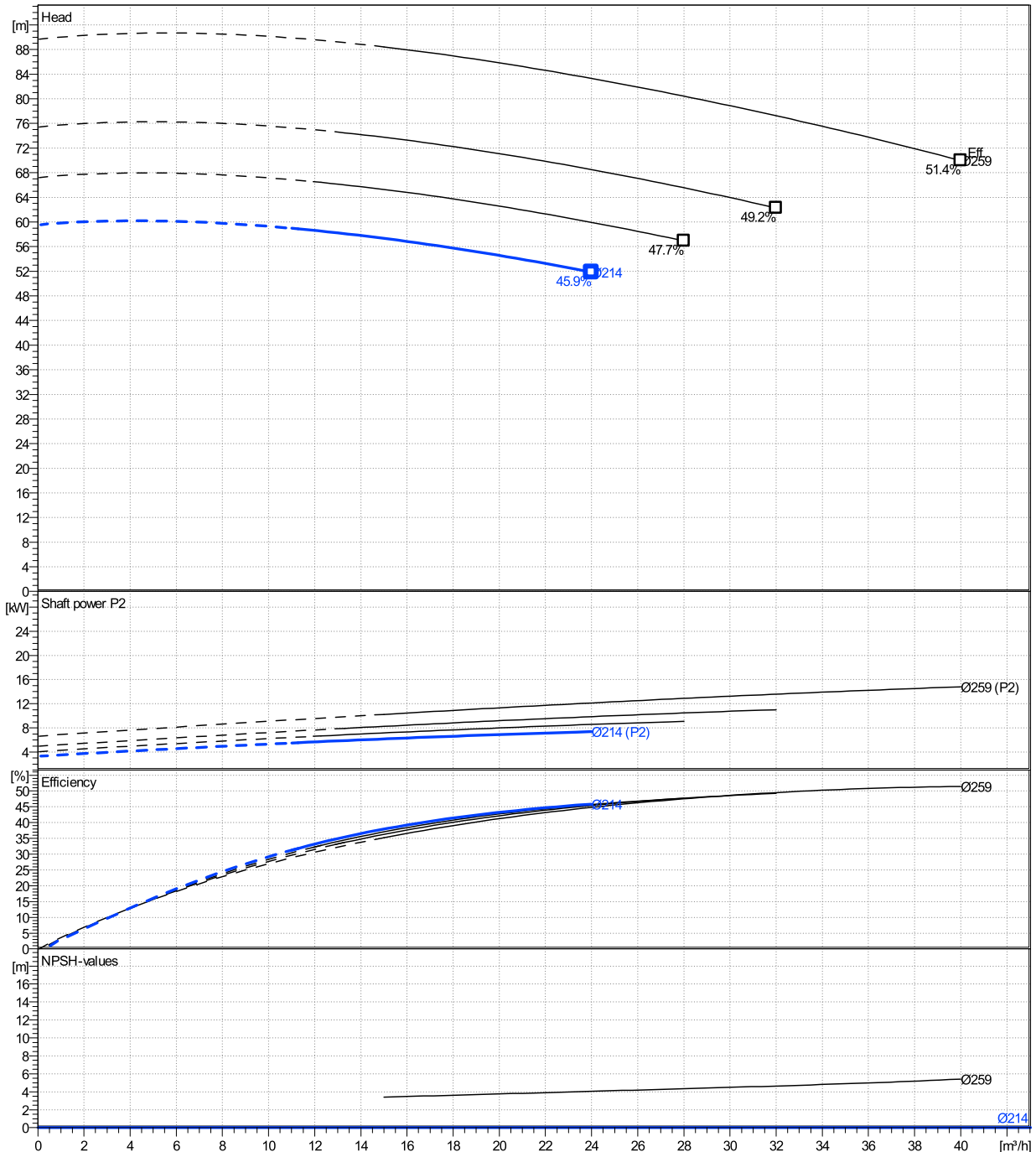

# LNTE 40-250/75/P25VCS4

## Dimensions

Company name  
Contact  
Phone number  
e-mail address

Close coupled  
2 poles motor  
PLM 132 B14 7,5 kW

Electrical and dimensional data refer to IE3 motor

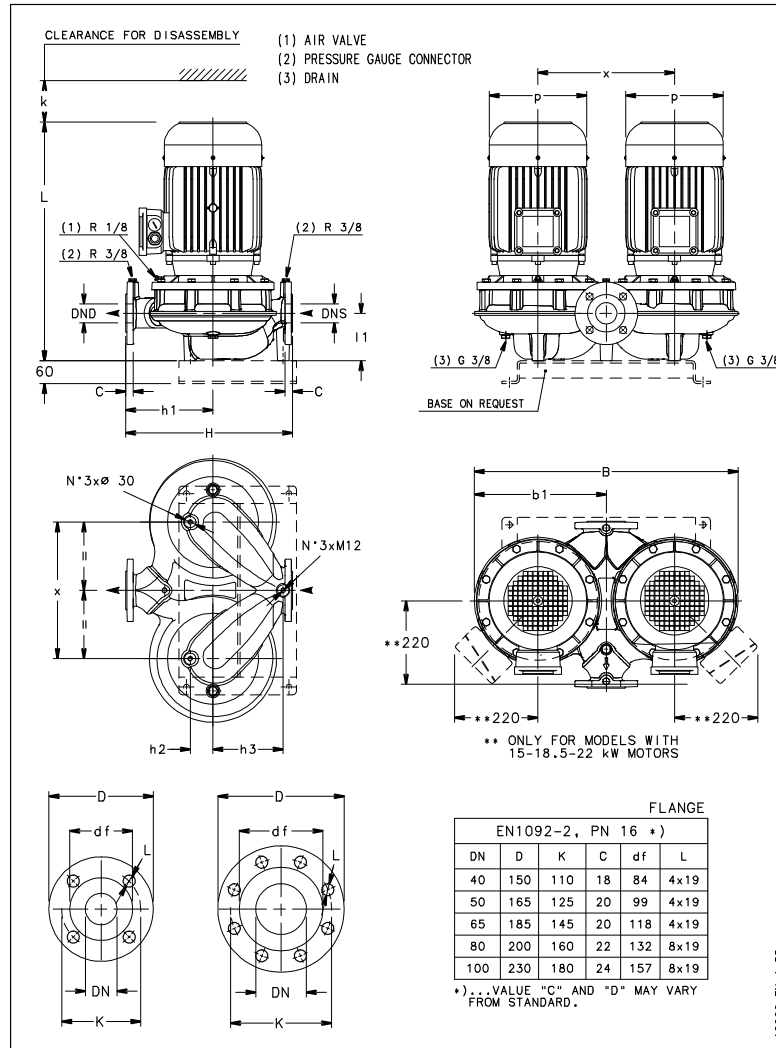

### Dimensions [ mm ]

B	745
b1	372.5
DND	40
DNS	40
H	440
h1	220
h2	65
h3	193
k	104
L	575
l1	110
p	256
x	410

### Weight

<b>Total weight</b>	<b>179 kg</b>
---------------------	---------------

### Connections

Suction nozzle		Discharge nozzle	
DN 40		DN 40	
PN 16		PN 16	
EN1092-2		EN1092-2	
C	18	C	18
D	150	D	150
df	84	df	84
DN	40	DN	40
K	110	K	110
L	4 x 19	L	4 x 19

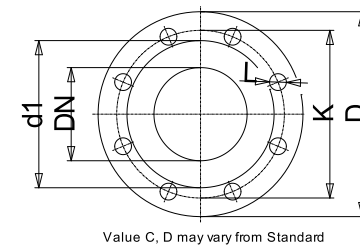

### Dimensions and weight without obligation

Project	Xylect-20969204
Block	LNTE 40-250/150/P25VCS4

Created by  
Created on 8/8/2023

Last update 8/8/2023