

LNTE 40-125/11/S25RCS4

Technical data

Company name
Contact
Phone number
e-mail address

Operating data						
1	Pumpe type	Single head pump		Fluid	Water, pure	
2	No. of pumps	1		Operating temperature t A	°C	4
3	Nominal flow	m ³ /h	0	Max / Min Operating Temperature mech. Seal	°C	120 / -25
4	Nominal head	m	0	pH-value at t A	7	
5	Static head	m	0	Density at t A	kg/m ³	1000
6	Inlet pressure	kPa	0	Kin. viscosity at t A	mm ² /s	1.569
7	Environmental temperature	°C	20	Vapor pressure at t A	kPa	100
8	Available system NPSH	m	0	Altitude	0	

Pump data						
9	Lubrication	Standard, Grease lubrication [Std]				
10	Execution	2 poles motor				
11	Design	In-Line single twin head				Impeller Ø
12	Operating speed	2900 rpm	Stages	1		
13	Suction nozzle	DN 40	/	PN 16	/	EN1092-2
14	Discharge nozzle	DN 40	/	PN 16	/	EN1092-2
15	Max. casing pressure	kPa				Flow
16	Max. working pressure	kPa	139.2			
17	Impeller type	Radial impeller				Head
18	Head H(Q=0)	m	14			
19	Max. shaft power	kW	1			
20	Pump weight	kg				Shaft power
21	Total weight	kg	57.0			Efficiency
						NPSH 3%

Materials						
22		Pump			Shaft Seal	
23	Volute Casing	Cast Iron			Single mechanical seal, without shaft sleeve	
24	Casing Cover	Cast Iron			eMG12 - Ø22mm	BQ7EGG-WA
25	Impeller	Stainless steel / AISI 304			Mechanical seal diameter	22 mm
26	Stub shaft	Stainless steel / AISI 316L			1. Rotating ring	Carbon graphite resin impregnated
27	Wear ring	Stainless steel / AISI 304			2. Stationary ring	SiC, silicon carbide, sintered press.less
28	Impeller lock nut and washer	Stainless steel / AISI 304			3. Secondary seal	Ethylene propylene rubber (EPDM)
29	Impeller key	Stainless steel / AISI 316L			4. Springs	CrNiMo - Steel
30	Fill and draing plugs	Nickel-plated brass			5. Others	EPDM - WRAS
31					Gaskets of the pump	Ethylene propylene rubber (EPDM)
32						
33						
34						
35						
36						
37						
38						
39						
40						
41						

Motor data					
42	Manufacturer	Lowara			
43	Specific design	IE3 3ph Flange Motor			
44	Type	SM 90R B14 1,1 kW			
45	Rated power	1.1 kW	Rated current	2.39 A	
46	Nominal speed	2870 rpm	Rated voltage	400 V	
47	Frame size	90R	Service factor	1	
48	Weight	kg 11.5	Degree of protection	IP55	

Remarks					
49					
50					
50					
52					

LNTE 40-125/11/S25RCS4

Performance curve

Company name
Contact
Phone number
e-mail address

	Ø mm	Pump capacity			Pump head		Shaft power P2			Frequency	Hz	50
		Operating range Min. m ³ /h	Max. m ³ /h	η Max. m ³ /h	H(Q=0) m	η Max. m	P2(Q=0) kW	Max. kW	η Max. kW	Operating speed	rpm	2900
actual	113	6.24	22	14.4	14.2	12.5	1.01	0.841	Nominal flow	m ³ /h	0	
Min.	0	/	/	14.4	14.2	12.5	/	0.841	Nominal head	m	0	
Max.	145	/	/	23.2	27.4	23.9	/	2.36	Inlet pressure	kPa	0	
									Static head	m	0	

Power datas referred to:

hydr. Performance acceptance acc. To EN ISO 9906 Class Grade 3B

Water, pure [100%] ; 4°C; 1000kg/m³; 1.57mm²/s

MEI: N.A - according to Ecodesign Directive 2009/125/EC and Regulation (EU) No.547/2012

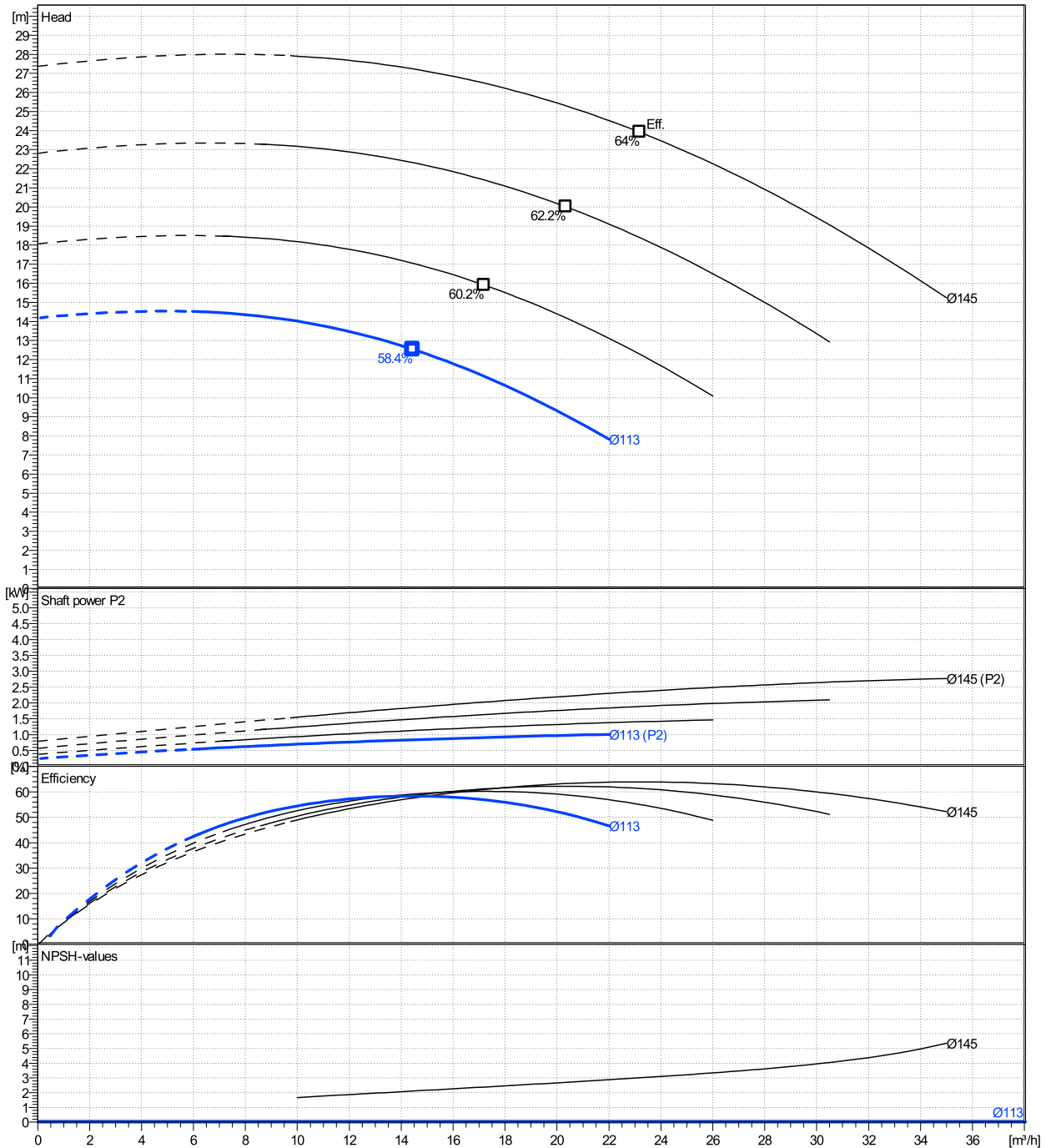

LNTE 40-125/11/S25RCS4

Dimensions

Company name
Contact
Phone number
e-mail address

Close coupled
2 poles motor
SM 90R B14 1,1 kW

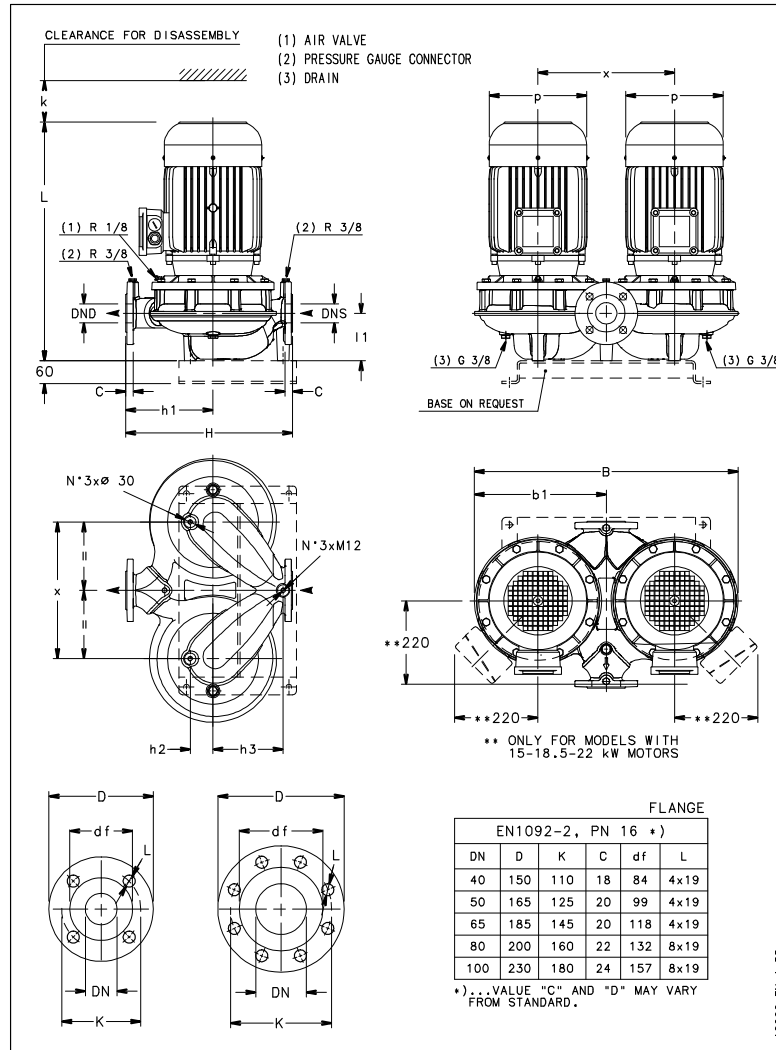

Dimensions [mm]

B	549
b1	274.5
DND	40
DNS	40
H	320
h1	180
h2	52
h3	110
k	94
L	463
l1	100
p	155
x	310

Weight

Total weight	57 kg
---------------------	--------------

Connections

Suction nozzle		Discharge nozzle	
DN 40		DN 40	
PN 16		PN 16	
EN1092-2		EN1092-2	
C	18	C	18
D	150	D	150
df	84	df	84
DN	40	DN	40
K	110	K	110
L	4 x 19	L	4 x 19

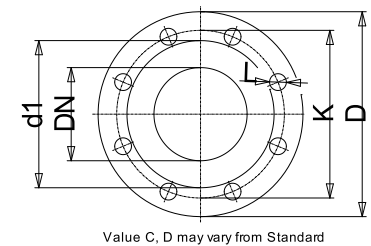

Dimensions and weight without obligation

Project	Xylect-20969139
Block	LNTE 40-125/30/P25RCS4

Created by	
Created on	8/8/2023

Last update 8/8/2023