

mainsboost

Mainsboost Charger MJ3

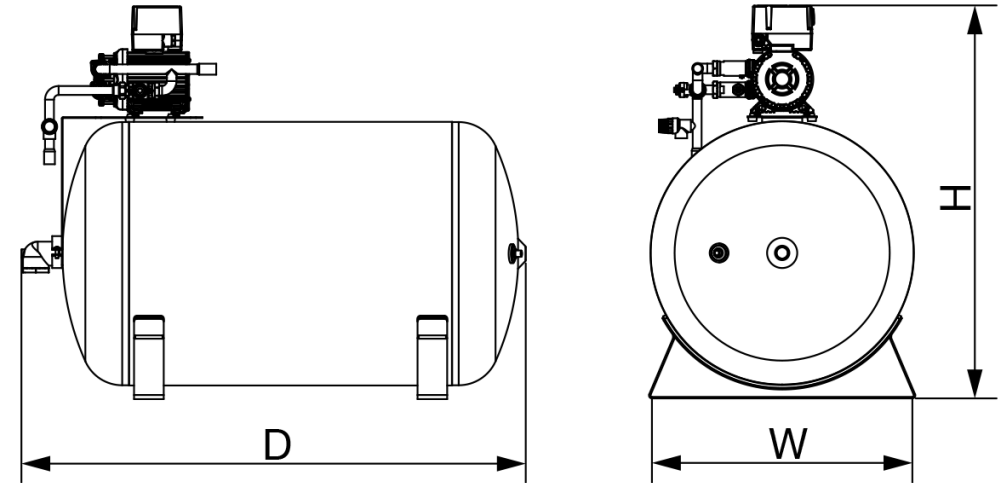
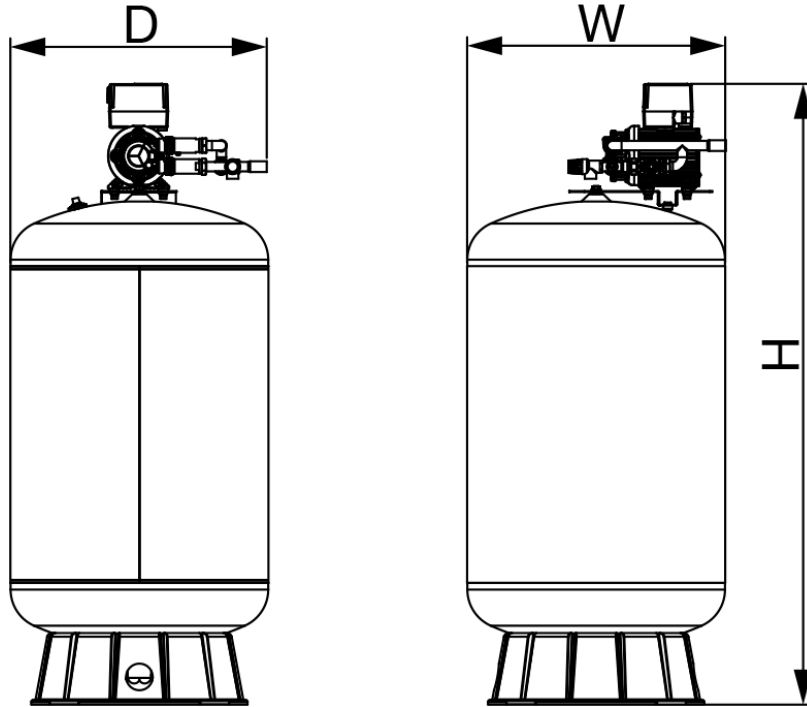

Model Description	Dim. 'H'	Dim. 'W'	Dim. 'D'
MB 100SV + MJ3 VM	1020 mm	440 mm	485 mm
MB 130SV + MJ3 VM	1325 mm	440 mm	485 mm
MB 200SV + MJ3 VM	1270 mm	535 mm	548 mm
MB 250SV + MJ3 VM	1445 mm	535 mm	548mm
MB 300SV + MJ3 VM	1730 mm	535 mm	548 mm
MB 450SV + MJ3 VM	1775 mm	660 mm	660 mm

Model Description	Dim. 'H'	Dim. 'W'	Dim. 'D'
MB 200SH + MJ3 HM	888 mm	540 mm	1026 mm
MB 250SH + MJ3 HM	888 mm	540 mm	1206 mm

Dimensions in millimetres

For further advice on selecting the correct pump call
or e-mail info@stpumps.co.uk

Issue 4018/1

Stuart Turner Ltd own the copyright within this document. The document may be printed for personal use only. The document must not be altered, reproduced or utilised in any way without written permission from Stuart Turner Ltd, Henley-on-Thames, Oxfordshire, RG9 2AD, England.

Stuart Turner Ltd reserve the right to amend the document or product specifications in line with it's policy of continuous development.

pumpassist
HELPLINE +44 (0) 800 31 969 80