

# aquaboost

## In-Tank Booster System (600 litre)

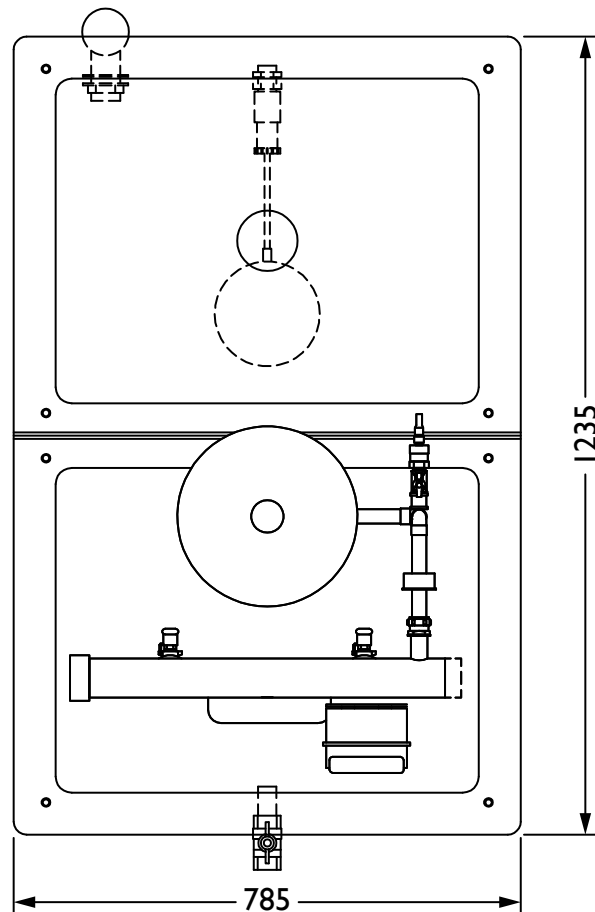

Plan

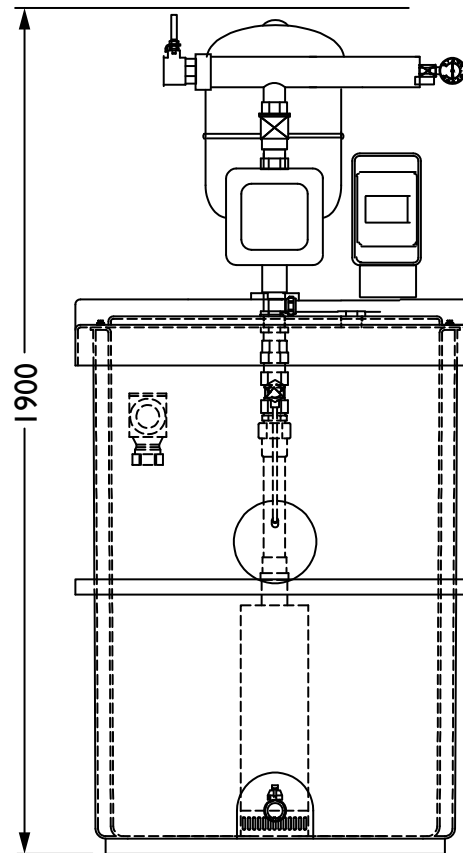

Front

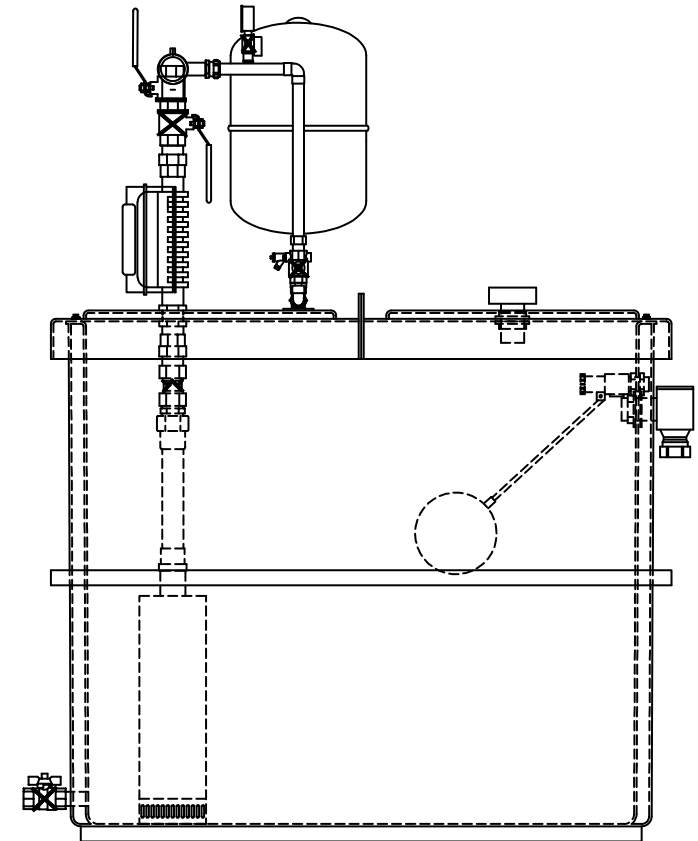

Side

Dimensions in millimetres

For further advice on selecting the correct pump call  
or e-mail [info@stpumps.co.uk](mailto:info@stpumps.co.uk)

Issue 4817/1

Stuart Turner Ltd own the copyright within this document. The document may be printed for personal use only. The document must not be altered, reproduced or utilised in any way without written permission from Stuart Turner Ltd, Henley-on-Thames, Oxfordshire, RG9 2AD, England.

Stuart Turner Ltd reserve the right to amend the document or product specifications in line with it's policy of continuous development.

**pumpassist**  
HELPLINE +44 (0) 800 31 969 80