

aquaboost

Booster Set (Vertical Twin) Installation, Operation & Maintenance Instructions

Please leave this instruction booklet with the owner as it contains important guarantee, maintenance and safety information



Read this manual carefully before commencing installation.

This manual covers the following products:

ABB V150-45-2V-1

Pt. No. 46684

ABB V150-60-2V-1

Pt. No. 46685

ABB V150-75-2V-1

Pt. No. 46686

ABB V260-65-2V-1

Pt. No. 46687

ABB V260-75-2V-1

Pt. No. 46688

ABB V260-85-2V-1

Pt. No. 46689



PRODUCT DESCRIPTION

Twin electric motor driven centrifugal pump set complete with an automatic variable speed duty/assist control system, incorporating pumps, VSD, transducer, pressure vessel and electronic control.

APPLICATION

The Aquaboost Booster Set (vertical twin) range is designed for pressure boosting stored, clean cold water into systems, where under gravity, no flow is available.

Inlet pressures to the pump and ambient temperatures must not exceed the values given in the technical specifications.



- **This pump set must not be used for any other application without the written consent of Stuart Turner Ltd.**
- **This pump MUST NOT be connected directly to the mains water supply.**
- **This appliance can be used by children aged from 8 years and above and persons with reduced physical, sensory or mental capabilities or lack of experience and knowledge if they have been given supervision or instruction concerning use of the appliance in a safe way and understand the hazards involved. Children shall not play with the appliance. Cleaning and user maintenance shall not be made by children without supervision.**
- **Children should be supervised to ensure that they do not play with the appliance.**

Please read installation details carefully as they are intended to ensure this product provides long, trouble free service. Failure to install the unit in accordance with the installation instructions will lead to invalidation of the warranty.

STORAGE

If this product is not to be installed immediately on receipt, ensure that it is stored in a dry, frost and vibration free location in its original packaging.

CONTENTS

	Page
Checklist	3
Important Facts - read before commencing installation	5
Location	7
Installation	9
Electrical	10
Control Programming	13
Commissioning	20
Maintenance	22
Technical Specification	23
Trouble Shooting	25
Guarantee	27

CHECKLIST

IMPORTANT: With the pump removed from its packaging check for any damage prior to installation. If any damage is found contact Stuart Turner Ltd within 24 hours of receipt.

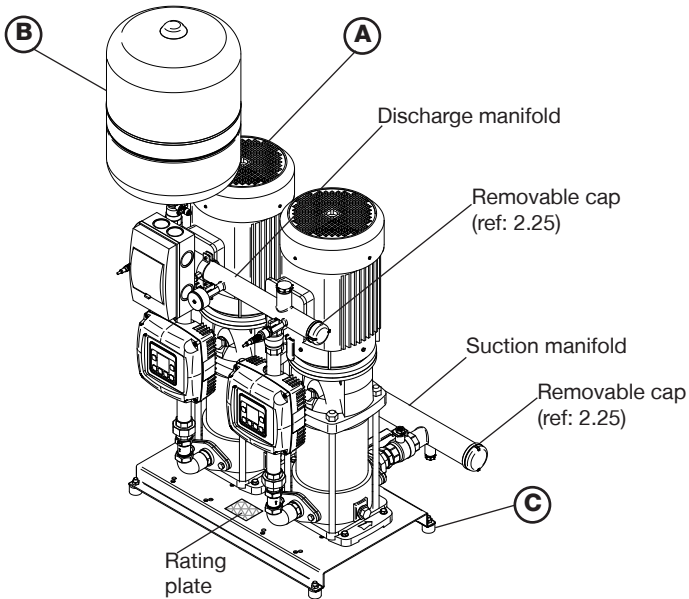
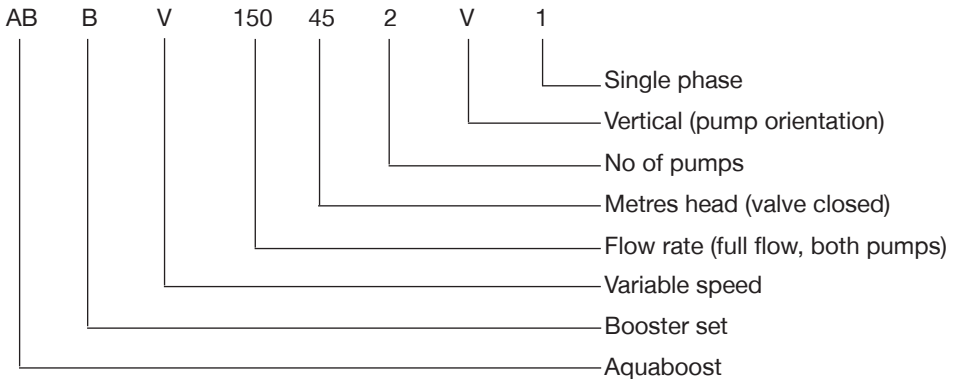

Fig. 1

Item	Description	Qty	Item	Description	Qty
(A)	Booster set	1	(C)	Anti-vibration mounts	4
(B)	Pressure vessel (supplied loose)	1			

Your product may vary slightly from the picture above.

Product Identification



Product Performance

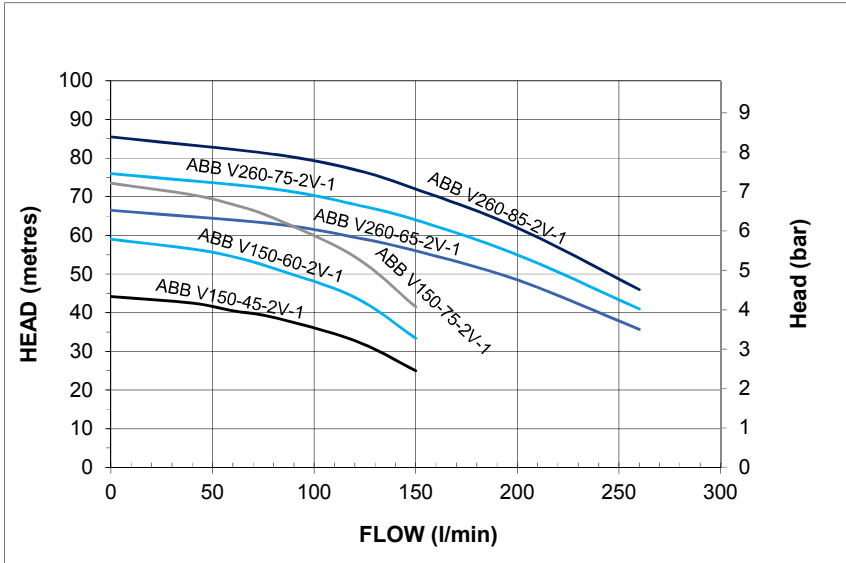

Fig. 2

Performance curve indicates maximum performance, both pumps running.

1 IMPORTANT FACTS: READ BEFORE COMMENCING PUMP INSTALLATION

A. Water storage capacity.

- 1.11 The cold water storage capacity must be sufficient to meet the flow rates required by the pumped equipment and any other water using fittings and appliances, which may be operated simultaneously.
- 1.12 Ensure the pump is primed as described in the priming section before starting, damage to the shaft seal will result otherwise. See Section 6 - Commissioning.

B. Water temperature

This unit is designed to pump cold water only which should not exceed the following values:

- 1.13 The maximum allowable water temperature is 23 °C.
- 1.14 The minimum allowable water temperature is 4 °C.

Note: Pump sets are available for handling greater temperatures, please contact us for further information.

C. Pipework - General

- 1.15 **Secure pipework:** Ensure pipework to and from the booster set is independently supported & clipped to prevent forces being transferred to inlet and outlet branches of pump. Flexible hoses not supplied.
- 1.16 **Flux:** Solder joints must be completed and flux residues removed prior to pump installation (**flux damage will void any warranty**).
- 1.17 **Pipework design:** Care should be taken in the design of pipework runs to minimize the risk of air locks e.g. use drawn bends rather than 90° bends.



- 1.18 **DO NOT** install a non-return valve, or devices which contain non-return valves, in the suction (inlet) pipework to the pump. The pump must be free to vent to the supply tank at all times.

- 1.19 **DO NOT** connect this pump to the mains water supply.

D. Plumbing Installation Regulations

- 1.20 The plumbing installation must comply with the current water and building regulations.
- 1.21 The plumbing installation must be installed by a qualified person.
- 1.22 The electrical installation must be carried out in accordance with the current national electrical regulations.
- 1.23 The electrical installation must be installed by a qualified person.

E. Pressure vessel

- 1.24 Ensure the pressure vessel is installed correctly before operating the unit, to avoid damage to the pumps/controls.



Do not attempt to dismantle the pressure vessel

Pressure vessel is charged at the factory see Section 7 - Maintenance for details.

F. **Lifting/Positioning**

- 1.25 **DO NOT** lift the booster set by the pipework or by the control panel, the pressure vessel is supplied loose for transport purposes, please ensure that the booster set has been installed and connected to the suction and discharge pipework before installing the pressure vessel. On no account should the pressure vessel be used to “manoeuvre” the booster set into place. Care should be taken when handling this product due to it’s weight.
- 1.26 This equipment must not be pressurised beyond maximum working pressure (refer to technical specifications).

2 LOCATION - GENERAL



- 2.11 **Access:** For emergencies and maintenance the booster set must be easily accessible.
- 2.12 **Protection:** The booster set must be located in a dry position, frost free and protected from freezing. Avoid environments which have a high ambient temperature, high humidity or excessive condensation. Avoid dust, corrosive gas, explosive gas, inflammable gas, grinding-fluid mist and salt damage, etc.
- 2.13 **Ventilation:** Ensure an adequate air flow to cool the pump. Separate the pump from other appliances that generate heat.
- 2.14 **Safety:** The motor casing can become very hot under normal operating conditions. Care must be taken to ensure it cannot be touched during operation.
- 2.15 **Water retention:** Site the pump in a location where in the unlikely event of a water leak, any spillage is contained or routed to avoid electrics or areas sensitive to water damage.
- 2.16 **Static inlet pressure:** Care must be taken to ensure the booster set has flooded suction from the cold water storage tank. Before deciding where to locate the unit check to ensure the static inlet head between pump and the bottom of the tank (Fig. 3) is at least 1 metre and does not exceed the max inlet head of 10 metres. Inlet pressures in excess of 3 metres should be taken into account when selecting the working pressure of the booster set, i.e. take the static inlet pressure away from the required working pressure.
- 2.17 **Booster set position:** The unit must be mounted as close to the water source as possible on a level surface, and if the plant-room has a chance of flooding it is recommended that the unit is installed on a suitable plinth capable of taking total working weight. If the optional anti-vibration bolt down mounts have been purchased then fix these to the floor/plinth then fix the booster set to the anti-vibration mounts.
- 2.18 Ensure that location of the unit allows adequate space to give reasonable access to all parts to accommodate all service/commissioning, must be a minimum of 250 mm and easily see/operate the readout/controls.
- 2.19 **Ambient temperature:** The pump must be sited in a location where the maximum ambient temperature does not exceed 40 °C.
- 2.20 **Pipework:** For optimum performance:
V150 models have 1.1/2 “ BSP suction and discharge manifolds.
V260 models have 2 “ BSP suction and discharge manifolds.
All isolation valves should be full bore, non-restrictive type.
Flexible hoses are available separately, please contact us for further information.
Discharge pipework should only be reduced when entering the terminal fittings.
Note: Inlet pipework must always be greater than or equal to the outlet pipework diameter.
- 2.21 **Static outlet pressure:** The static outlet head (Fig. 3) must also be within the maximum requirement of 13 metres. The booster set should have been selected to provide the required operating pressure at the highest outlet after allowing for the static height of the highest fitting and the frictional losses in the pipework. The minimum requirement at the highest outlet is usually 1 bar but can be up to 3 bar depending on the type of fittings used.

Cont ...

- 2.22 **Direction of flow:** See Fig. 1 to identify the suction and discharge connections.
- 2.23 **Isolating valves:** Separate system isolating valves (non restrictive) must be fitted to the suction and discharge of the pump set on the system side of the flexible hoses.

3 INSTALLATION

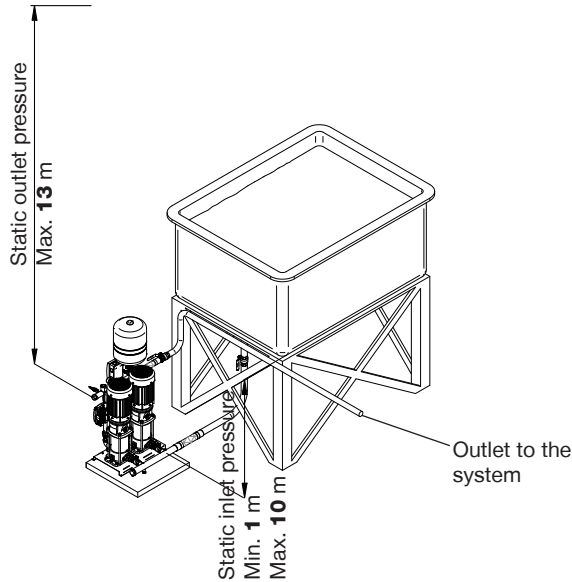

Fig. 3

- 3.11 **The cold water supply: Must be a DEDICATED AIR FREE** supply via a tank connector and must be able to self vent. Flexible hoses are supplied with the pump set and must be fitted between both suction and delivery manifolds and the installation pipework.
Do not connect to the mains.
- 3.12 The suction and discharge caps can be installed on either end of the manifold to facilitate ease of installation, please ensure these are water tight before switching the unit on (see Fig. 1).
- 3.13 **Pressure vessel:** The pressure vessel is supplied loose, this must be fitted to the connection on the discharge pipework. The connection is sealed with two 'O'-rings within the end of the connection, ensure the 'O'-rings are not damaged during assembly. To fit the vessel tighten the running nut and open the isolation valve.

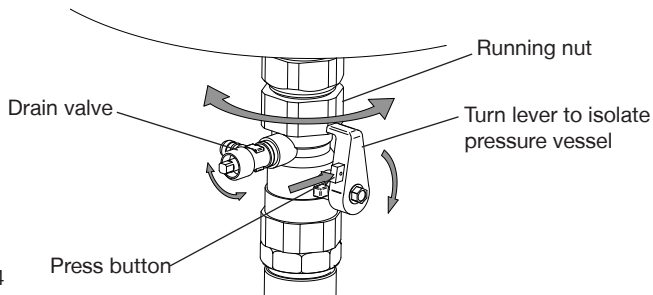

Fig. 4

- 3.14 **DO NOT** install the booster set where the control panel can be exposed to direct sunlight or near sources of heat.
- 3.15 Non-return valves **must not** be fitted to suction or delivery as this may cause incorrect operation and damage to the unit.

Cont ...

4 ELECTRICAL



- 4.11 **Regulations:** The electrical installation must be carried out in accordance with the current national electrical regulations and installed by a qualified person.
- 4.12 **Safety:** In the interests of electrical safety a 30 mA residual current device (**R.C.D. not supplied**) should be installed in the supply circuit. Any RCD fitted must be suitable for operation with inverter drives, i.e. Type A suitable for pulsation DC leakage current. This may be part of a consumer unit or a separate unit.
- 4.13 Before starting work on the electrical supply ensure power supply is isolated.
- 4.14 **Install an emergency stop key separately from the isolator.**
- 4.15 **Earthing:** This appliance must be permanently earthed via the supply cord, which must be correctly connected to the earth point located in the terminal box. **The inverter should be protected separately against ground fault.**
- 4.16 **Additional earthing:** Certain installations may require additional earthing arrangements such as equipotential bonding. Reference should be made to the relevant regulations concerning this subject to ensure compliance.
- 4.17 **Connections:** The pump set must be permanently connected to the mains supply using a suitable sized cable using the double pole isolator fitted to the pump set.
- 4.18 **Wiring of connection unit:**



WARNING: This appliance must be earthed.

Do not remove any cover of electrical components for at least **5 minutes** to allow total discharge of components after supply has been disconnected. When making the electrical connections ensure all appropriate anti-static procedures are taken.

4.19 Wiring Diagram:

Connect the pump set to the supply in accordance with the wiring diagram shown below.

Note:
This switch does not isolate all connections to this panel. Isolate elsewhere before working on this equipment

- Note:
1. This panel must be protected by a Type D M.C.B or motor rated BS88 fuse, rating see Section 3.21.
 2. All protective devices are set to manual reset.
 3. Panel wiring: All cables are Tri-rated
Mains=Phase Bm/Blk/Gry 2.5 mm²
Motors=Phase Bm/Blk/Gry 1.5 mm²
240 V a.c. Live=Brown/Neutral=Blue 0.5 mm²
DC Live=Red/Neutral=Blue 0.5 mm²
Volt free=White 0.5 mm²
 4. Earth Bonding=G/Y 4.0 mm²

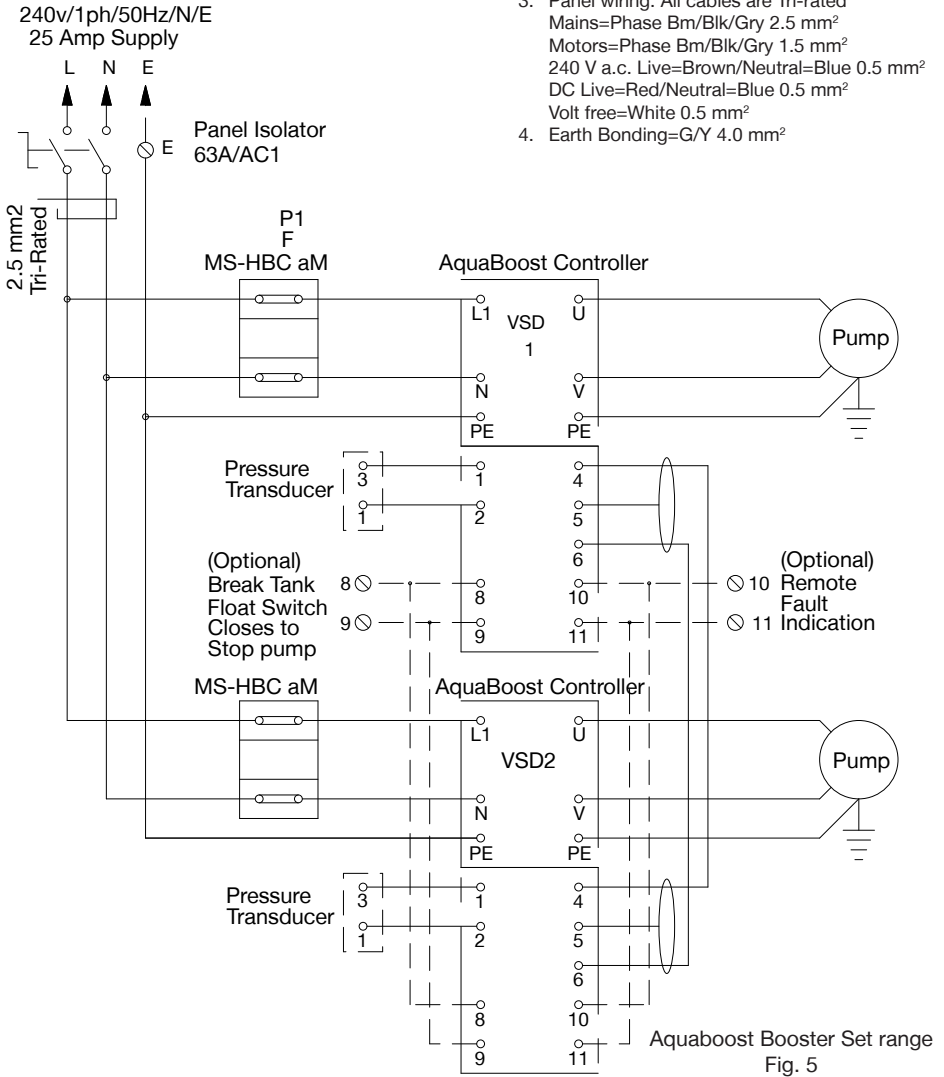

Cont ...

4.20 **Fuses:** Two fuses are fitted in the connection box fixed to the top of the pump set, accessed via the clear front panel.

4.21 **Pump controller:**



- **The connection of the alarms can distribute power even when the frequency converter is turned off. Ensure that there is no residual voltage on the terminals of the alarms.**



- **All the power terminals and other terminals must be accessible after installation is completed. The maximum output frequency must not exceed the design frequency of the pump being controlled. Operating at a frequency higher than the allowable frequency can cause higher current absorption and damage to the device.**
- **If it is necessary to remove the frequency converter, remove only the covers required in order to disconnect the electrical cables. Take care not to damage the electronic cards.**
- **Failure to comply with the safety regulations not only causes risk to personal safety and damage to the equipment, but also invalidates the warranty.**







This pump set is controlled with two linked pump controllers, the controllers allow the system pressure to be set on the digital display. The pump speed will be varied by the controllers to maintain the set system pressure (Constant pressure mode), if the set system pressure cannot be maintained with one pump running, the second pump will automatically be started to increase the system pressure to the set pressure (Duty/Assist).

Both controllers are electronically linked (Master and Slave) this allows the pressure set on the master controller to be used for the slave controller, simplifying the setting process. The master controller is the left hand unit and will be confirmed when switching the unit on, the  icon will appear permanently on the master display panel.

5 CONTROL PROGRAMMING



Fig. 6

-  Pump Start
-  Pump Stop
-  Access to programming menu/scroll up
-  Programming/confirm
-  Increase or scroll left
-  Decrease or scroll right

5.11 Screen format:

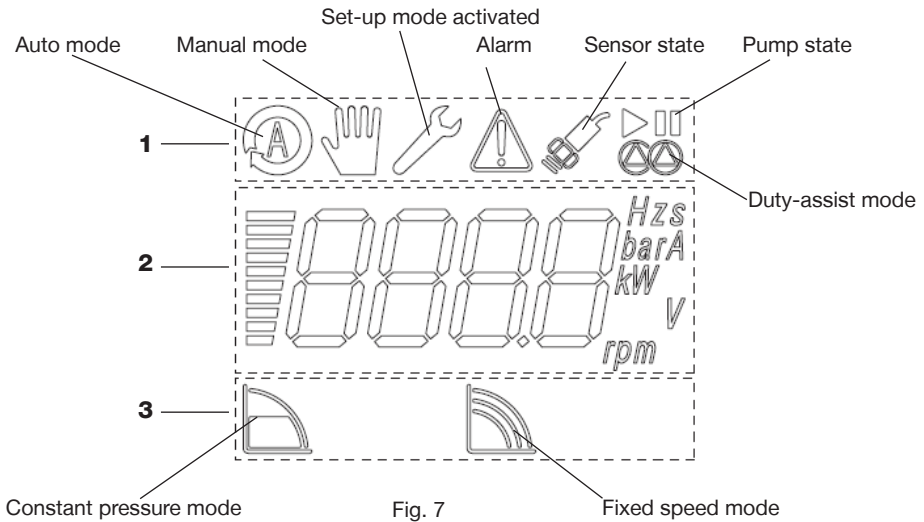

Cont ...

5.12 The display is divided into three key areas (see Fig. 7):

1 - System icons:



Auto mode

The system is operating in auto mode.



Manual mode

The system is operating in manual mode.



Set-up mode activated

It shows that the setup menu is activated. When an icon is blinking you are modifying a parameter. You can confirm with  enter.



Alarm

Indicates that a fault has occurred, an error number will appear in the display area. When in the set-up mode the alarm icon will not appear.



Sensor state

Indicates that the system is connected with the pressure transducer; if it blinks there is a fault with the pressure transducer connected to that controller.



Pump state

Indicates if the pump is running or in stand-by state.



Duty-assist mode

Indicates that the controls are in duty-assist mode. The 2 upper symbols indicate if the pumps are running or in stand-by mode. The lower symbol confirms if the pump is the master (permanently alight) or slave (blinking).

2 - Display area:

Is composed of an incremental bar proportional with the displayed value and its unit of measure. The display is backlit, the light will be turned off after 20 seconds of system inactivity.

3 - Operating icons:



Constant pressure mode

The system keeps the pressure constant when the flow rate of water varies dependant on demand.



Fixed speed mode

In this mode the controller operates the pump at a fixed speed that the user can choose according to need (not used).

5.13 Low water cutout:

To protect the booster set from running out of water a float switch can be fitted into the supply tank and should be wired into terminals 8 and 9 of **both** controllers (see Fig. 8).

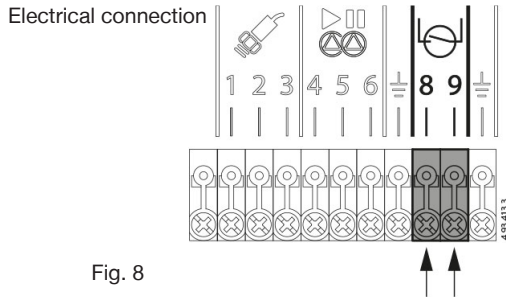

Fig. 8

5.14 Remote alarm connection:

Using terminals 10 and 11, a remote alarm can be connected to **both** controllers (see Fig. 9).

The remote alarm can be used to signal:

- error on the frequency converter (nO)
- the frequency converter is running (nC).



Operating limits: 250 V a.c., 450 mA maximum resistive current.

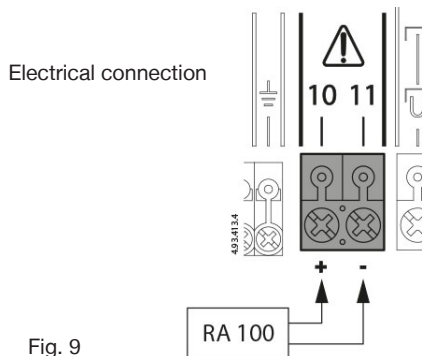

Fig. 9

5.15 **Dry running protection:**

The controllers are equipped with two methods of dry running protection:-

- 1) The system pressure is monitored by the controller, if the system pressure drops below a pre-set level (SP07) for longer than a pre-set time (AP05) the pumps will be stopped.
- 2) If an external float or level switch is to be connected to the controllers (see Page 14, Fig. 8) the controller will stop the pumps when the switch is activated, when the switch is re-set by the rising water level, the pumps will re-start automatically after a pre-set time delay (AP19)

For entering the programming mode see 5.24.

5.16 **Parameters:**

On the controller the following information is displayed:

- Pump status
- Programming
- Alarms

5.17 **Pump status:**

The following controller operating conditions can be displayed:-

- 1) Frequency of the electrical supply to the pump (this will be different on each controller, between 30 & 50 Hz)
- 2) System pressure in bar
- 3) Current drawn (amps) by the pump that is connected to the controller (this will be different on each controller)



Starting from the basic display by pushing of the directional arrow  (plus) or  (minus) these parameters are displayed for example:







Fig. 10



5.18 Programming:

To display the programming parameters, select  (menu) and the following will be displayed progressively:

- UP - User settings: these are the basic settings that the user can change.
- AP - Advanced settings: these settings are available only to qualified personnel. Password entry is required (contact PumpAssist for assistance).
- SA - Technical assistance settings: these are the advanced parameters, only technical assistance personnel are allowed to access this menu. Password entry is required (contact PumpAssist for assistance).
- MAN - Fixed speed mode activation: this allows activation of the fixed speed mode and the working frequency. Only qualified personnel are allowed to access this menu. Password entry is required (contact PumpAssist for assistance).
- AE - Advanced parameters: this allows display of the secondary parameters which can be useful for system diagnostics.
 Example: AE01 software release
 AE02 supply voltage (V)
 AE03 last 5 faults

5.19 Supply voltage display:

By pushing the  button (menu) the UP parameter appears. Select the AE parameter by pushing the  (plus) up to arrive at the correct parameter , confirm with  (enter).

Select the parameter  by pushing the button  (plus) and confirm with  (enter).

Supply voltage is displayed.

5.20 UP - User settings

No	Description	Factory settings	Modifications	Note
UP01	restart mode power failure [rA = automatic; rM = manual]	rA		
UP02	Nominal pump current (A)	0.1		
UP03	Nominal pump frequency (HZ)	50		
UP04	Direction of rotation [---]= std rotation; E--- = inverted rotation]	---		
UP05	Set point pressure (bar)	1.5		

UP01-04 are factory set and should not be changed.

5.21 AP - Advance settings

To enter password is required contact PumpAssist for assistance on +44 (0) 800 31 969 80.

No	Description	Factory settings	Modifications	Note
AP01	Pressure transducer set-up (bar) [sensor full-scale]	10		
AP02	Ramp down (s)	3		
AP03	Ramp-up (s) [fixed value for MM]	2MT 0 MM		
AP04	Time before stop (s)	30		
AP05	Dry run pressure (s)	10		
AP06	First dry run time	60		
AP07	Dry run pressure	1.5		
AP08	System dynamic [1 = fast dynamic; 5 = slow dynamic]	3		
AP09	Duty-assist mode [oFF; UU = duty-assist mode with double inverter; UF= duty-assist mode with an inverter]	oFF		
AP010	Master/Slave setting MAS = master; SLA = slave	SLA		
AP011	Reset to factory set-up			
AP012	Digital input activation [0 = oFF; 1 = no; 2 - nC]	1		
AP013	Digital output activation [0 = oFF; 1 = on; 2 = no; 3 - nC]	0		
AP014	Restart fall pressure set-up (bar)			
AP015	Pump address	SLA1		
AP016	Duty-assist mode start fall pressure set-up (bar)	0.3		
AP017	Duty-assist mode restart delay (s)	10		
AP018	Duty-assist mode fall pressure limit set-up (bar)	0.6		
AP019	Digital input delay time [float switch delay time] (s)	30		

Cont ...

5.22 SA - Technical assistance settings

To enter password is required contact PumpAssist for assistance on +44 (0) 800 31 969 80.

No	Description	Factory settings	Modifications	Note
SA01				
SA02				
SA03	Pressure PID (Proportional gain)	2.8		
SA04	Pressure PID (Integral time constant)	5.5		
SA05	Pressure PID (Derivative time constant)	5.0		
SA06	Min. run frequency (Hz)	30		
SA07	Max. frequency (Hz)	60		
SA08	Set point pressure step up (bar)	0.3		
SA09	Pressure step up time (s)	3		
SA010	Pressure step up ramp (bar/s)	0.3		
SA011	Set point control ramp (bar/s)	0.4		
SA012	Carrier frequency	7010		
SA013	Singlephase starting requery (Hz)	80		
SA014	Singlephase starting voltage (V)	195		
SA015	Nominal voltage (V)	220		













5.23 MAn - Fixed speed mode activation

To enter password is required contact PumpAssist for assistance on +44 (0) 800 31 969 80.

No	Description	Factory settings	Modifications	Note
MAn1	Fixed speed mode activation	oFF		
MAn2	Working frequency [MAn2 ≤ UP03] (Hz)	45		

5.24 Programming

To enter programming:-

- 1) Select  (menu). Use the buttons  (plus) or  (minus) to select the parameter to be modified and confirm with  (enter).
- 2) Use the buttons  (plus) or  (minus) to select the parameter to be modified and confirm with  (enter).
- 3) Using buttons  (plus) or  (minus) increase or decrease the value. From this moment the set-up icon  start blinking until the value is confirmed with  (enter).
- 4) To exit the program, push  (menu) until when you arrive back on the initial display screen. The set-up icon  will disappear once the action is complete.

Cont ...

6 COMMISSIONING



- 6.11 **Isolate the booster set before pressure testing the system. Over pressure could damage the pressure transducer and diaphragm in the pressure vessel.**
- 6.12 **Each booster set is factory set to the required parameters as per the agreed specification and per the operating parameters set out elsewhere in this manual. We strongly recommend that commissioning and service work is carried out by the manufacturer's personnel or appointed agents. Please contact our technical sales department for information on our commissioning and service contract packages.**

6.13 System Flushing

The pipework system should be flushed out prior to the pump being connected to ensure any contaminants/chemical residues and foreign bodies are removed from elsewhere in the system.

- 6.14 **Water supply:** Always ensure that water storage capacity is adequate to meet the demand. Ensure the pump chambers are full of water before starting the unit. Failure to do this could result in seal damage. To ensure dry running does not occur the pumps must be primed as described in priming section below. **Do not run pump(s) dry.**

6.15 Priming:



Never operate the unit with inlet and/or outlet isolating valves in the closed position. Damage will occur!

The pump's must be primed (filled with water) before starting.

- (a) Turn on the service valves and vent/prime pump head.
- (a) Loosen priming plug on each pump and allow an even flow of water this may take a few seconds.
- (b) Re-seal draining plug, nipping tight. The pump is now ready to start.

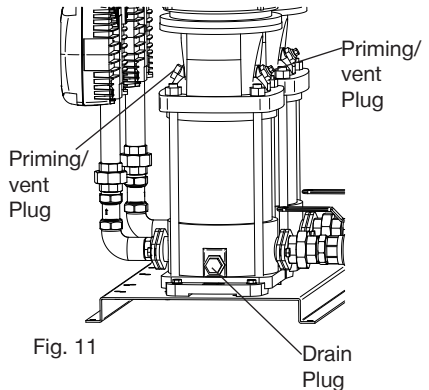



Fig. 11



6.16 Starting:

- a) Ensure the pumps are vented and the water supply turned on.
- b) Turn on the electrical supply at the isolator switch in the connection box.
- c) The pump set will automatically start if the rA option (default setting) is selected. If the pump set does not start press  button and the controller will start the pumps.













Cont ...

- d) The pump will continue to run until the system set pressure is reached; once this pressure is reached the pump(s) will slow and stop.
- e) If the pumps have not primed correctly the pressure will not increase, repeat the priming procedure detailed above.

6.17 **Stopping:**

- a) Press the  button, the pump(s) will stop. OFF will be displayed on the screen.
- b) To re-start press  button.

6.18 **Setting system set pressure (UP05):**

- a) Press  to access menu.
- b) Using  and  find menu UP, press  to enter.
- c) Using  and  find parameter UP05, press  to enter.
- d) Using  and  adjust the set pressure, press  to enter. During this process the  icon will be flashing at the top of the screen. **Warning - DO NOT set pressure outside the performance of the pump.**
- e) To exit press  until the initial screen is seen.
- f) The  icon will disappear from the top of the screen.

See 7.13 for re-setting pressure vessel.

- 6.19 **For Further Technical Support:** Phone PumpAssist on +44 (0) 800 31 969 80. Our staff are trained to help and advise you over the phone.

7 MAINTENANCE



7.11 Turn off water supplies to the booster set and release pressure by opening water outlets before attempting maintenance.

7.12 Pressure vessel:

The pressure vessel fitted to this booster set does not require any maintenance during the life of the product.

If the system set pressure has been adjusted, the pressure vessel air charge pressure will need to be adjusted as detailed below.

- a) Isolate pumps electrically.
- b) Isolate the pressure vessel from the system by turning the valve at the base of the vessel (press button at the base of the valve handle to unlock) (Fig. 4).
- c) Release system water pressure from the vessel by opening the drain valve in the fitting at the base of the vessel (Fig. 4). **Warning: A considerable volume of water will be released as the vessel discharges.**
- d) With the drain valve open, unscrew the black plastic cover to reveal the Schrader valve. Check air charge at Schrader valve (Fig. 12) using a tyre pressure gauge.
- e) Replenish air charge by injecting air into the vessel via the Schrader valve using a car or bicycle pump (Fig. 12). The vessel charge pressure **must** be 2/3 of the system set pressure, i.e. with a system set pressure of 4.2 bar, the vessel charge pressure must be set to 2.8 bar. **Do not** exceed a vessel charge pressure of 4 bar.
- f) Replace the black plastic cover to the Schrader valve to ensure a leak tight seal.
- g) Close the drain valve.
- h) Open the isolating valve at the base of the vessel.
- i) Turn on the electrical supply at the isolator switch in the connection box.
- j) To restart see Section 6.16.

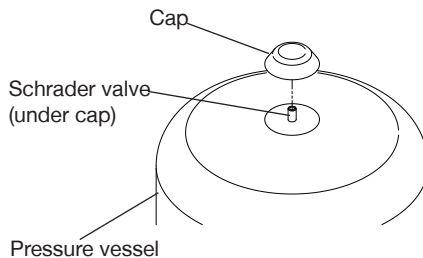

Fig. 12



Damage may occur to the vessel if the incorrect charge pressure is used.

8 TECHNICAL SPECIFICATION

Aquaboost Model		ABB V150-45-2V-1 50 Hz 46684	ABB V150-60-2V-1 50 Hz 46685	ABB V150-75-2V-1 50 Hz 46686	
General	Guarantee	2 Years			
	WRAS approval	Approved materials			
Features	Pump type	Centrifugal			
	Mechanical seal	EPDM / Carbon / Ceramic			
	Anti-vibration feet	✓	✓	✓	
	Diaphragm Tank Size	24 litres			
	Diaphragm Tank Water Capacity	12 litres			
Materials	Pump body	Stainless steel			
	Impeller	Stainless steel			
Performance	Performance	See Curve Fig. 2			
	Minimum static inlet pressure	1 metre			
	Maximum static inlet pressure	10 metres			
	Maximum working pressure*	16 bar			
	Maximum ambient air temperature	40 °C			
	Min / Max water temperature	Min 4 °C / Max 23 °C			
Connections	Pump set connections	Suction: G 2 ", Discharge: G 1½ "			
Motor	Type	Induction type, thermally protected			
	Duty rating	Continuous (S1)			
Electrical	Power supply / phase / frequency	230 V a.c./1/50 Hz			
	Per Pump	Current per pump (full load)	2.6 Amps	2.9 Amps	4.2 Amps
		Power consumption (per pump)	0.55 kW	0.75 kW	1.1 kW
		Fuse rating (pump)	10 Amps		
Physical	Enclosure protection	IP55			
	Length	600 mm			
	Width	650 mm			
	Height	1250 mm			
	Weight (including fittings)	110 Kg	120 Kg	125 Kg	

Note: Although input power is single phase all pumps are three phase.

Cont ...

Aquaboost Model		ABB V260-65-2V-1 50 Hz 46687	ABB V260-75-2V-1 50 Hz 46688	ABB V260-85-2V-1 50 Hz 46689	
General	Guarantee	2 Years			
	WRAS approval	Approved materials			
Features	Pump type	Centrifugal			
	Mechanical seal	EPDM / Carbon / Ceramic			
	Anti-vibration feet	✓	✓	✓	
	Diaphragm Tank Size	24 litres			
	Diaphragm Tank Water Capacity	12 litres			
Materials	Pump body	Stainless steel			
	Impeller	Stainless steel			
Performance	Performance	See Curve Fig. 2			
	Minimum static inlet pressure	1 metre			
	Maximum static inlet pressure	10 metres			
	Maximum working pressure*	16 bar			
	Maximum ambient air temperature	40 °C			
	Min / Max water temperature	Min 4 °C / Max 23 °C			
Connections	Pump set connections	Suction: G 2 ", Discharge: G 1½ "			
Motor	Type	Induction type, thermally protected			
	Duty rating	Continuous (S1)			
Electrical	Power supply / phase / frequency	230 V a.c./1/50 Hz			
	Per Pump	Current (full load)	5.2 Amps	8.0 Amps	8.0 Amps
		Power consumption	1.5 kW	2.2 kW	2.2 kW
		Fuse rating	10 Amps		
Physical	Enclosure protection	IP55			
	Length	600 mm			
	Width	725 mm			
	Height	1300 mm			
	Weight (including fittings)	130 Kg	135 Kg	140 Kg	

*Note: Indicates maximum casing pressure.

Stuart Turner Ltd reserve the right to amend the specification without notice.

8.11 **Noise:** The equivalent continuous A-weighted sound pressure level at a distance of 1 metre from the pump does not exceed 70 dB(A).



Cont ...

9 TROUBLE SHOOTING GUIDE

9.11 Controller alarm code

No	Description	Causes
ER01	No water	The device is in failure due to no water. The system try to restart automatically. - One attempt every 10 minutes for 6 times. - One attempt every hour for 24 times. - One attempt every 24 hours for 30 times.
Er02	Pressure transducer fault	Cable not connected, broken connection, pressure transducer damaged.
Er03	Low supply voltage	Supply voltage lower then 190 V. - The system automatically restart when the clamp voltage is higher than 190 V.
Er04	High rectified voltage	Supply voltage higher than 250 V. - The system automatically restart when the clamp voltage is lower than 250 V.
Er05	Memory failure	Contact Stuart Turner.
Er06	Overcurrent in the electro pump motor	Contact Stuart Turner.
Er07	Overcurrent in the frequency converter	Contact Stuart Turner.
ER08	Direct short circuit controller on output	Contact Stuart Turner.
Er09	Overheating	Ensure good air flow around the booster set
Er10	Overheating of the power module	Contact Stuart Turner.
Er11	Low voltage 24 V	Contact Stuart Turner.
Er12	Stop for float switch intervention	The system will restart with a delay defined by AP19 from the state variation of the float switch. The control panel for remote alarm not report this alarm.
Er13	Internal hardware error	Contact Stuart Turner.
Er14	Duty-assist mode communication error	Check the RS 485 connection or that both pumps are enabled.



In case of multiple fault, scroll with the buttons  (plus) or  (minus) to visualize the fault sequence. In case of thermal block it is advised to check the causes that have created the problem before restart the pump operation.

Symptoms	Probable Cause	Recommended Action
Pump will not start.	<p>Electrical supply.</p> <p>Pump Jammed.</p> <p>Pump current exceeds controller set current.</p> <p>Recommended static inlet/outlet heads exceeded.</p> <p>Internal motor thermotrip activated.</p> <p>Reduced or no water supply.</p> <p>Pressure transducer fault.</p> <p>Stopped due to tank level float switch (if fitted).</p> <p>Power failure has stopped pump.</p>	<p>Check power supply. Check fuse (see fuse section). Check circuit breaker is set. Check wiring connections.</p> <p>See controller alarm code (error ER06).</p> <p>See controller alarm code. (error Er06).</p> <p>Re-position pump (see pump location section).</p> <p>Wait for thermotrip to auto-reset and check that duty point and run time is within specification (see technical specification). (errors Er09 & Er10).</p> <p>Check supply into break tank (error Er01 or Er12).</p> <p>Check wiring to transducer/transducer function (error Er02).</p> <p>Check water/float switch operation (if fitted), (error Er12).</p> <p>Ensure the controllers are set to automatically reset after power failure (setting UP01, set to rA).</p>
Reduced/intermittent flow.	<p>Insufficient water supply.</p> <p>Incorrect pipe sizes.</p> <p>Blocked inlet filters.</p> <p>Pump cannot supply water required by the system.</p>	<p>Check supply into break tank (error Er01).</p> <p>Check for correct pipe sizing, see Page 7 - Section 2.20.</p> <p>Clean inlet filters, if fitted.</p> <p>Check pump is sized to suit system demand.</p>
<p>Pump runs on with outlets closed.</p> <p>or</p> <p>Pump cycles (hunts) on/off frequently.</p>	<p>Leak in system.</p> <p>System pressure set too high.</p> <p>Low pressure in pressure vessel.</p> <p>Debris under non-return valve sealing face.</p>	<p>Check terminal fittings and pipe joints.</p> <p>Check system set pressure is within the capability of the pump(s) fitted to the set (setting UP05).</p> <p>Check pressure in pressure vessel (see maintenance section).</p> <p>Run at full flow to try and flush away debris or remove, clean or replace non-return valve.</p>

9.12 Environment Protection: Your appliance contains valuable materials which can be recovered or recycled.
At the end of the products' useful life, please leave it at an appropriate local civic waste collection point.

Cont ...

10 YOUR GUARANTEE

Congratulations on purchasing a Stuart Turner Booster Set.

We are confident this pump set will provide many years of trouble free service as all our products are manufactured to the very highest standard.

This Stuart Booster Set is guaranteed to be free from defects in materials or workmanship for 1 year from the date of purchase, extendable to two years subject to evidence of the required maintenance having taken place.

Within the guarantee period we will repair, free of charge, any defects in the pump resulting from faults in material or workmanship, repairing or exchanging the whole unit as we may reasonably decide.

Not covered by this guarantee: Damage arising from incorrect installation, improper use, unauthorised repair, normal wear and tear and defects which have a negligible effect on the value or operation of the pump.

Reasonable evidence must be supplied that the product has been purchased within the guarantee term prior to the date of claim (such as proof of purchase or the pump serial number).

This guarantee is in addition to your statutory rights as a consumer. If you are in any doubt as to these rights, please contact your local Trading Standards Department.

In the event of a claim please telephone **'PumpAssist'** or return the pump and flexible hoses with the accessories removed e.g pipes etc. If you have any doubt about removing a pump, please consult a professional.

+44 (0) 800 31 969 80

Proof of purchase should accompany the returned unit to avoid delay in investigation and dealing with your claim.

You should obtain appropriate insurance cover for any loss or damage which is not covered by Stuart Turner Ltd in this provision.

Please record here for your records.

TYPE NO.	SERIAL NO.	DATE PURCHASED



DECLARATION OF CONFORMITY

2006/42/EC

BS EN ISO 12100-1, BS EN ISO 12100-2, BS EN 809

2014/35/EU

BS EN 60335-1, BS EN 60335-2-41

2014/30/EU

BS EN 55014-1, BS EN 55014-2, BS EN 55022, BS EN 61000-3-2, BS EN 61000-3-3,
BS EN 61000-4-2, BS EN 61000-4-3, BS EN 61000-4-4, BS EN 61000-4-5, BS EN 61000-4-6,
BS EN 61000-4-11

1999/519/EC

BS EN 62233

2011/65/EU

2008/108EC

IT IS HEREBY CERTIFIED THAT THE STUART ELECTRIC MOTOR DRIVEN PUMP AS SERIAL NUMBER BELOW, COMPLIES WITH THE ESSENTIAL REQUIREMENTS OF THE ABOVE E.E.C. DIRECTIVES.



RESPONSIBLE PERSON
AND MANUFACTURER

STUART TURNER LIMITED
HENLEY-ON-THAMES, OXFORDSHIRE
RG9 2AD ENGLAND.

Signed.....  Technical Director

Stuart Turner are an approved company to BS EN ISO 9001:2008



Stuart Turner Ltd, Henley-on-Thames, Oxfordshire RG9 2AD ENGLAND

Tel: +44 (0) 1491 572655, Fax: +44 (0) 1491 573704

info@stpumps.co.uk www.stuart-turner.co.uk