

RST22/RST37/RST55/RST75



APPLICATION

- New designed double frame case for circumferential flow assuring superior motor xcooling effect.
- Heavy duty designed electric motor for continous use with thermal overload protection against overheating.
- Top discharge outlet.
- Coil for dry type motor can be rewound without removal of stator from motor frame.
- Long Lasting durability for continous running.
- Shaft with Stainless sleeve, protect shaft long running without damage.
- Impeller, motor casing, outer pump casing, shaft, strainer, all bolt and screws in stainless steel AISI 304. Impeller also available in high chror hard case iron.
- Double mechanical seal. (1 x silicon + 1 x carbon).
- Agriculture irrigation.
- Transfer of seawater.
- Aquatic displays, waterfalls, fountains.
- Bilge pump for boat and vessels.
- Construction yard.
- Suitable for drainage lightly waste water also for water including abrsive solids.

CONSTRUCTION

RST22-RST37

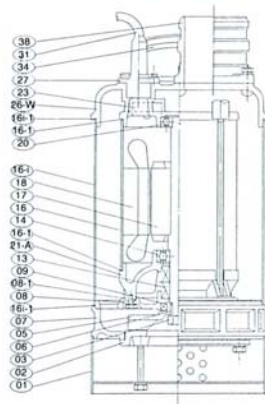

RST22/RST37

NO.	DESCRIPTION	MATERIAL	NO.	DESCRIPTION	MATERIAL
01	STRAINER	SUS 304	16I-1	GASKET	NBR
02	SUCTION COVER	FCD 400	17	ROTOR	SUS 304
03	NUT	SUS 304	18	STATOR	SUS 304
05	IMPELLER	FCD 400	20	BEARING (UPPER)	
06	KEY	SUS 304	21A	MOTOR BOTTOM COVER	FCD 400
07	PUMP HOUSING	FCD 400	16-1	GASKET	NBR
08	OIL CHAMBER	FC 200	23	OVERLOAD PROTECTOR	
08-1	GASKET	NBR	26W	UPPER COVER	FC 200
09	LIP SEAL (LOWER)	NBR	27	CABLE GLAND	SUS 304
13	MECHANICAL	SIC/CAR	31	CABLE	PVC
14	BEARING (LOWER)		34	HANDLE	FCD 400
16	MOTOR CASE	SUS 304	38	DISCHARGE OUTLET	FC 200
16I	OUTER PUMP CASE	SUS 304			

RST55-RST75

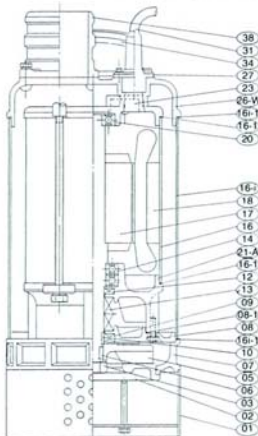

RST55/RST75

NO.	DESCRIPTION	MATERIAL	NO.	DESCRIPTION	MATERIAL
01	STRAINER	SUS 304	16I	OUTER PUMP CASE	SUS 304
02	SUCTION COVER	FCD 400	17	ROTOR	SUS 304
03	NUT	SUS 304	18	STATOR	SUS 304
05	IMPELLER	FCD 400	20	BEARING (UPPER)	
06	KEY	SUS 304	21A	MOTOR BOTTOM COVER	FC 200
07	PUMP HOUSING	FCD 400	16-1	GASKET	NBR
08	OIL CHAMBER	FCD 400	23	OVERLOAD PROTECTOR	
09	LIP SEAL (LOWER)	NBR	26W	UPPER COVER	FC 200
10	SLEEVE	SUS 304	16I-1	GASKET	NBR
12	LIP SEAL (UP)	NBR	27	CABLE GLAND	SUS 304
13	MECHANICAL	SIC/CAR	31	CABLE	PVC
14	BEARING (LOWER)		34	HANDLE	FCD 400
16	MOTOR CASE	SUS 304	38	DISCHARGE OUTLET	FC 200

Performance Curves

Dimensions

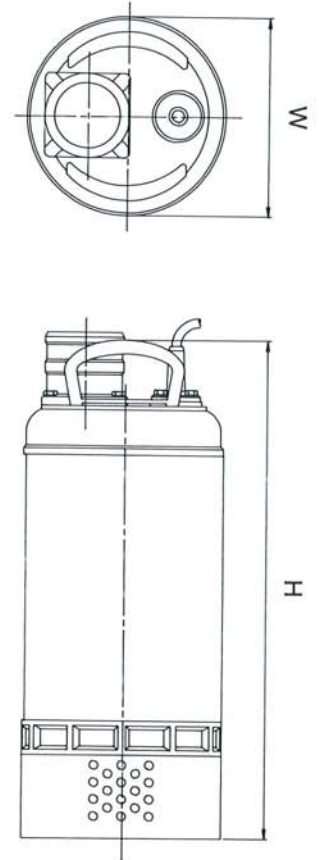
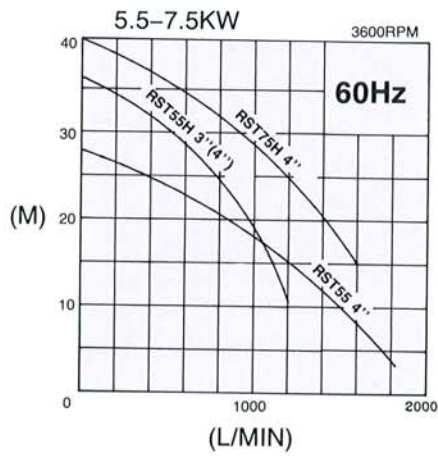
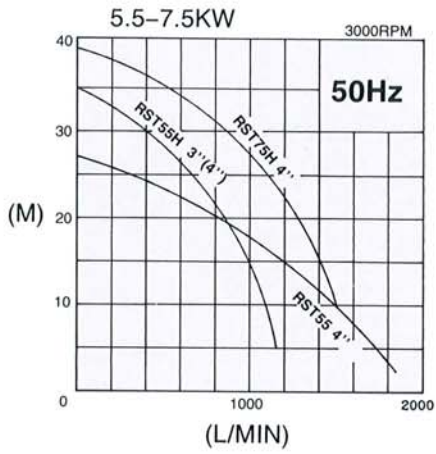
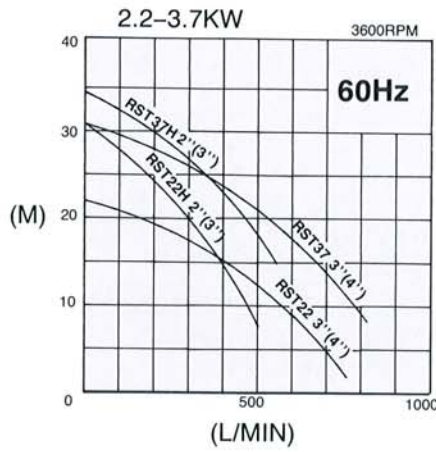
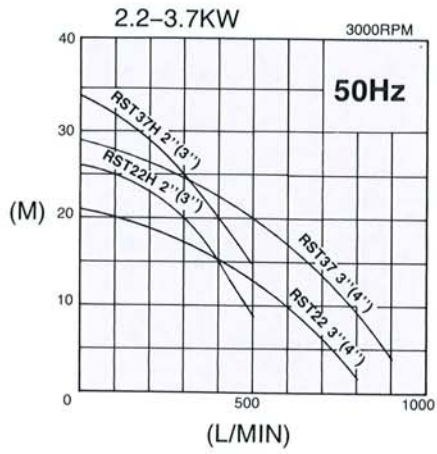

Specifications

Pump type	Output H.P.	Discharge [mm]	Voltage 50Hz or 60Hz	Continuous		Weight kg	Dimension[mm]	
				Head m	Capacity L/min		H	W
RST22H	3	2"/3"	3 phase 220-460V	20	300	50	530	250
RST22	3	3"/4"		15	410	50	530	250
RST37H	5	2"/3"		25	300	55	535	250
RST37	5	3"/4"		20	500	55	535	250
RST55H	7.5	3"/4"		25	680	70	600	250
RST55	7.5	4"		20	810	70	640	250
RST75H	10	4"		30	880	75	640	250