

**Qty. Description**

1 CRN 155-4-1 A-F-A-E-HQQE



Note! Product picture may differ from actual product

Product No.: [99143275](#)

Vertical, multistage centrifugal pump with inlet and outlet ports on same the level (inline). Pump materials in contact with the liquid are in high-grade stainless steel. The Grundfos cartridge shaft seal ensures high reliability, safe handling, and easy access and service. Power transmission is via a rigid split coupling. Pipe connection is via DIN flanges.

The pump is fitted with a 3-phase, fan-cooled asynchronous motor.

**Controls:**

Frequency converter: NONE

**Liquid:**

Pumped liquid: Water  
 Liquid temperature range: -40 .. 120 °C  
 Liquid temperature during operation: 20 °C  
 Density: 998.2 kg/m<sup>3</sup>

**Technical:**

Pump speed on which pump data are based: 2976 rpm  
 Rated flow: 155 m<sup>3</sup>/h  
 Rated head: 102.3 m  
 Pump orientation: Vertical  
 Shaft seal arrangement: Single  
 Code for shaft seal: HQQE  
 Curve tolerance: ISO9906:2012 3B

**Materials:**

Base: Stainless steel  
 EN 1.4408  
 Impeller: Stainless steel  
 EN 1.4401  
 Bearing: WC/WC  
 Support bearing: Graflon  
 Material certified according to: European standards

**Installation:**

Maximum ambient temperature: 55 °C  
 Maximum operating pressure: 16 bar  
 Max pressure at stated temp: 16 bar / 120 °C  
 Type of connection: DIN

Qty.	Description
	<p>Size of inlet connection: DN 150            Size of outlet connection: DN 150            Pressure rating for pipe connection: PN 16            Flange size for motor: FF500</p> <p><b>Electrical data:</b>            Motor standard: IEC            Motor type: SIEMENS            IE Efficiency class: IE3            Rated power - P2: 55 kW            Power (P2) required by pump: 55 kW            Mains frequency: 50 Hz            Rated voltage: 3 x 380-420D/660-725Y V            Rated current: 99,0-90,0/57,0-52,0 A            Starting current: 670-670 %            Cos phi - power factor: 0.89            Rated speed: 2975 rpm            Efficiency: IE3 94,3%            Motor efficiency at full load: 94.3-94.3 %            Motor efficiency at 3/4 load: 94.5-94.5 %            Motor efficiency at 1/2 load: 93.9-93.9 %            Number of poles: 2            Enclosure class (IEC 34-5): 55 Dust/Jetting            Insulation class (IEC 85): F</p> <p><b>Others:</b>            Net weight: 637 kg            Gross weight: 779 kg            Shipping volume: 2.04 m<sup>3</sup>            Thrust handling device: N            Approvals: CE, EAC, ACS, WRAS            Country of origin: DK            Custom tariff no.: 84137075</p>

## 99143275 CRN 155-4-1 A-F-A-E-HQQE 50 Hz

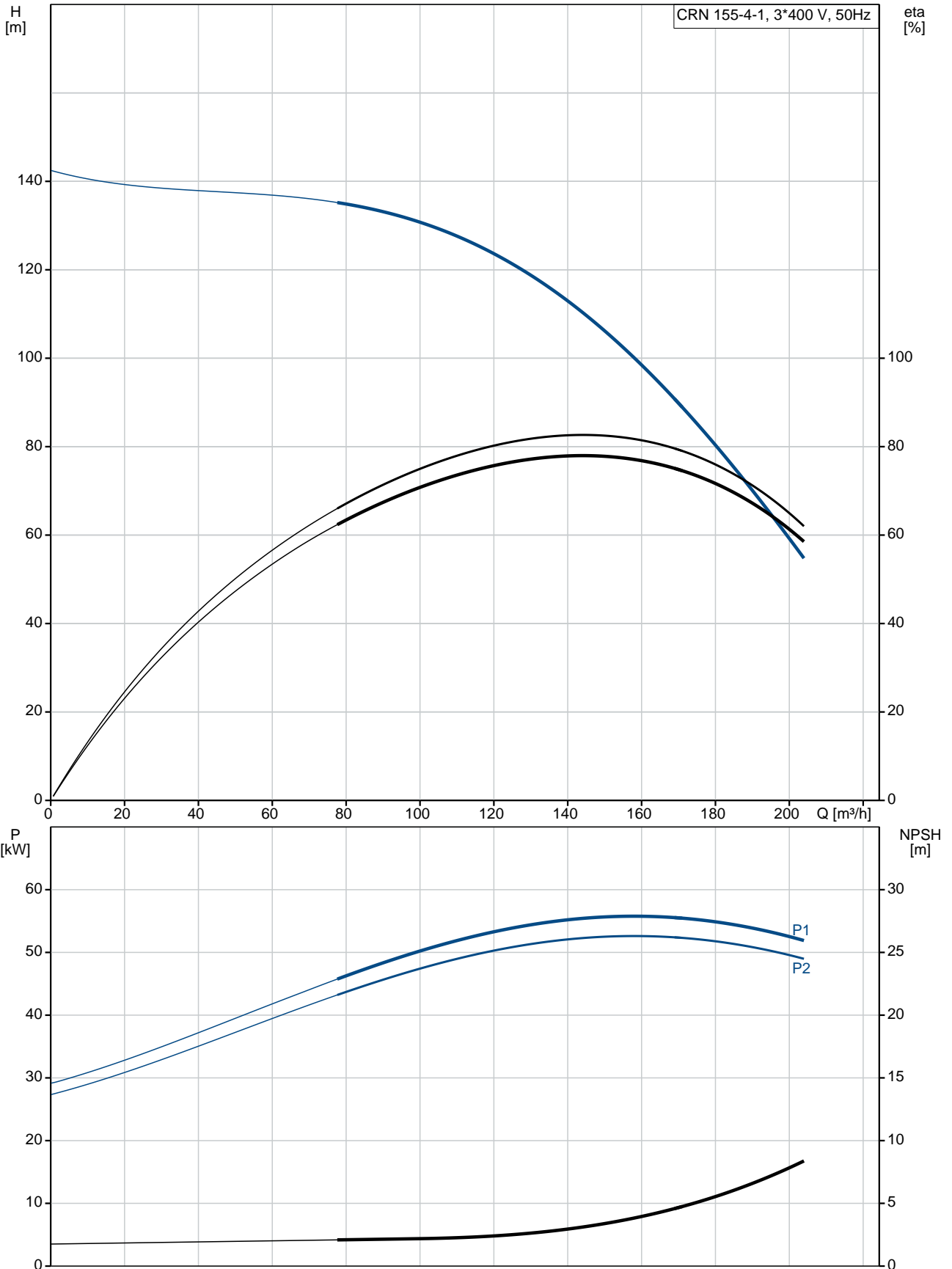

Description	Value
<b>General information:</b>	
Product name:	CRN 155-4-1 A-F-A-E-HQQE
Product No:	99143275
EAN number:	5712607553159
<b>Technical:</b>	
Pump speed on which pump data are based:	2976 rpm
Rated flow:	155 m <sup>3</sup> /h
Rated head:	102.3 m
Head max:	142.4 m
Stages:	4
Impellers:	4
Number of reduced-diameter impellers:	1
Low NPSH:	N
Pump orientation:	Vertical
Shaft seal arrangement:	Single
Code for shaft seal:	HQQE
Curve tolerance:	ISO9906:2012 3B
Pump version:	A
Model:	A
Cooling:	IC 411
<b>Materials:</b>	
Base:	Stainless steel EN 1.4408
Impeller:	Stainless steel EN 1.4401
Material code:	A
Code for rubber:	E
Bearing:	WC/WC
Support bearing:	Graflon
Material certified according to:	European standards
<b>Installation:</b>	
Maximum ambient temperature:	55 °C
Maximum operating pressure:	16 bar
Max pressure at stated temp:	16 bar / 120 °C
Type of connection:	DIN
Size of inlet connection:	DN 150
Size of outlet connection:	DN 150
Pressure rating for pipe connection:	PN 16
Flange size for motor:	FF500
Connect code:	F
<b>Liquid:</b>	
Pumped liquid:	Water
Liquid temperature range:	-40 .. 120 °C
Liquid temperature during operation:	20 °C
Density:	998.2 kg/m <sup>3</sup>
<b>Electrical data:</b>	
Motor standard:	IEC
Motor type:	SIEMENS
IE Efficiency class:	IE3
Rated power - P2:	55 kW
Power (P2) required by pump:	55 kW
Mains frequency:	50 Hz
Rated voltage:	3 x 380-420D/660-725Y V
Rated current:	99,0-90,0/57,0-52,0 A
Starting current:	670-670 %
Cos phi - power factor:	0.89

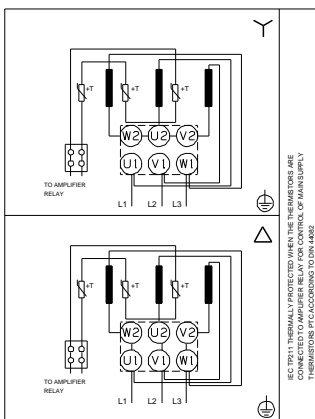
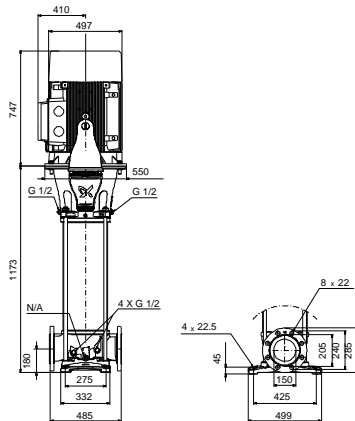
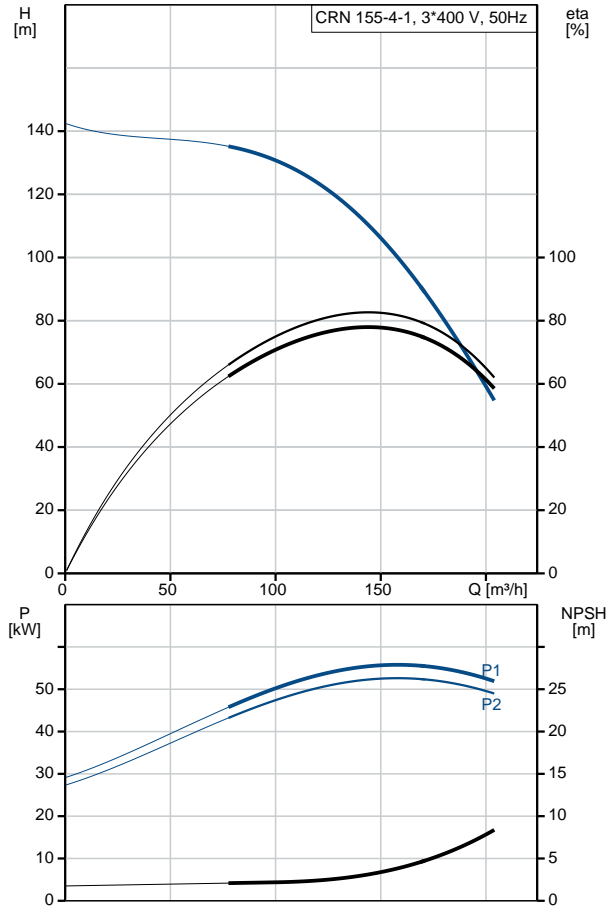



Company name:

Created by:

Phone:

Date:

12/03/2019

Description	Value
Rated speed:	2975 rpm
Efficiency:	IE3 94,3%
Motor efficiency at full load:	94.3-94.3 %
Motor efficiency at 3/4 load:	94.5-94.5 %
Motor efficiency at 1/2 load:	93.9-93.9 %
Number of poles:	2
Enclosure class (IEC 34-5):	55 Dust/Jetting
Insulation class (IEC 85):	F
Motor protec:	PTC
Motor No:	81U15338
<b>Controls:</b>	
Frequency converter:	NONE
<b>Others:</b>	
Net weight:	637 kg
Gross weight:	779 kg
Shipping volume:	2.04 m <sup>3</sup>
Thrust handling device:	N
Approvals:	CE, EAC, ACS, WRAS
Country of origin:	DK
Custom tariff no.:	84137075