

Qty. Description

1 CRN 155-3 A-F-A-E-HQQE



Note! Product picture may differ from actual product

Product No.: [99143274](#)

Vertical, multistage centrifugal pump with inlet and outlet ports on same the level (inline). Pump materials in contact with the liquid are in high-grade stainless steel. The Grundfos cartridge shaft seal ensures high reliability, safe handling, and easy access and service. Power transmission is via a rigid split coupling. Pipe connection is via DIN flanges.

The pump is fitted with a 3-phase, fan-cooled asynchronous motor.

Controls:

Frequency converter: NONE

Liquid:

Pumped liquid: Water
 Liquid temperature range: -40 .. 120 °C
 Liquid temperature during operation: 20 °C
 Density: 998.2 kg/m³

Technical:

Pump speed on which pump data are based: 2967 rpm
 Rated flow: 155 m³/h
 Rated head: 82.5 m
 Pump orientation: Vertical
 Shaft seal arrangement: Single
 Code for shaft seal: HQQE
 Curve tolerance: ISO9906:2012 3B

Materials:

Base: Stainless steel
 EN 1.4408
 Impeller: Stainless steel
 EN 1.4401
 Bearing: WC/WC
 Support bearing: Graflon
 Material certified according to: European standards

Installation:

Maximum ambient temperature: 55 °C
 Maximum operating pressure: 16 bar
 Max pressure at stated temp: 16 bar / 120 °C
 Type of connection: DIN

Qty.	Description
	<p>Size of inlet connection: DN 150 Size of outlet connection: DN 150 Pressure rating for pipe connection: PN 16 Flange size for motor: FF400</p> <p>Electrical data: Motor standard: IEC Motor type: SIEMENS IE Efficiency class: IE3 Rated power - P2: 45 kW Power (P2) required by pump: 45 kW Mains frequency: 50 Hz Rated voltage: 3 x 380-420D/660-725Y V Rated current: 81,0-74,0/47,0-43,0 A Starting current: 690-690 % Cos phi - power factor: 0.89 Rated speed: 2960 rpm Efficiency: IE3 94,0% Motor efficiency at full load: 94.0-94.0 % Motor efficiency at 3/4 load: 94.5-94.5 % Motor efficiency at 1/2 load: 94.4-94.4 % Number of poles: 2 Enclosure class (IEC 34-5): 55 Dust/Jetting Insulation class (IEC 85): F</p> <p>Others: Net weight: 517 kg Gross weight: 635 kg Shipping volume: 1.44 m³ Thrust handling device: N Approvals: CE, EAC, ACS, WRAS Country of origin: DK Custom tariff no.: 84137075</p>

99143274 CRN 155-3 A-F-A-E-HQQE 50 Hz

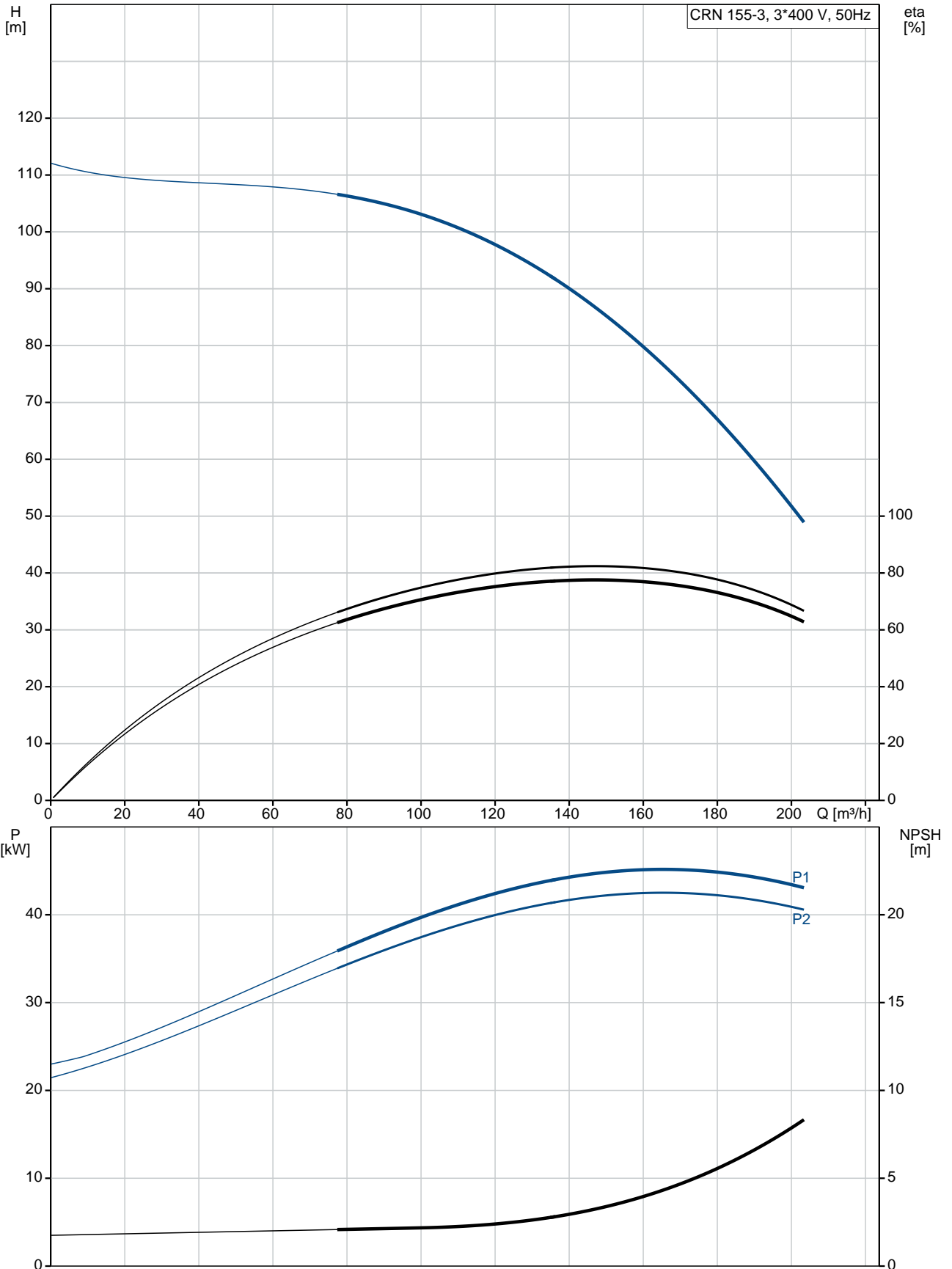

Description	Value
General information:	
Product name:	CRN 155-3 A-F-A-E-HQQE
Product No:	99143274
EAN number:	5712607553135
Technical:	
Pump speed on which pump data are based:	2967 rpm
Rated flow:	155 m ³ /h
Rated head:	82.5 m
Head max:	112 m
Stages:	3
Impellers:	3
Low NPSH:	N
Pump orientation:	Vertical
Shaft seal arrangement:	Single
Code for shaft seal:	HQQE
Curve tolerance:	ISO9906:2012 3B
Pump version:	A
Model:	A
Cooling:	IC 411
Materials:	
Base:	Stainless steel EN 1.4408
Impeller:	Stainless steel EN 1.4401
Material code:	A
Code for rubber:	E
Bearing:	WC/WC
Support bearing:	Graflon
Material certified according to:	European standards
Installation:	
Maximum ambient temperature:	55 °C
Maximum operating pressure:	16 bar
Max pressure at stated temp:	16 bar / 120 °C
Type of connection:	DIN
Size of inlet connection:	DN 150
Size of outlet connection:	DN 150
Pressure rating for pipe connection:	PN 16
Flange size for motor:	FF400
Connect code:	F
Liquid:	
Pumped liquid:	Water
Liquid temperature range:	-40 .. 120 °C
Liquid temperature during operation:	20 °C
Density:	998.2 kg/m ³
Electrical data:	
Motor standard:	IEC
Motor type:	SIEMENS
IE Efficiency class:	IE3
Rated power - P2:	45 kW
Power (P2) required by pump:	45 kW
Mains frequency:	50 Hz
Rated voltage:	3 x 380-420D/660-725Y V
Rated current:	81,0-74,0/47,0-43,0 A
Starting current:	690-690 %
Cos phi - power factor:	0.89
Rated speed:	2960 rpm

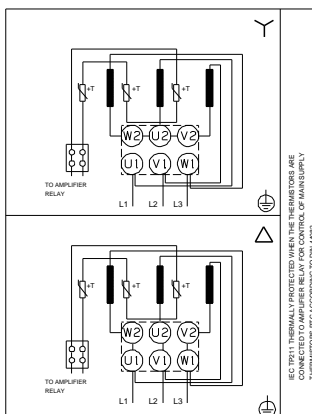
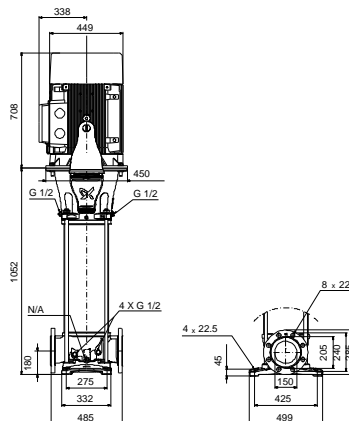
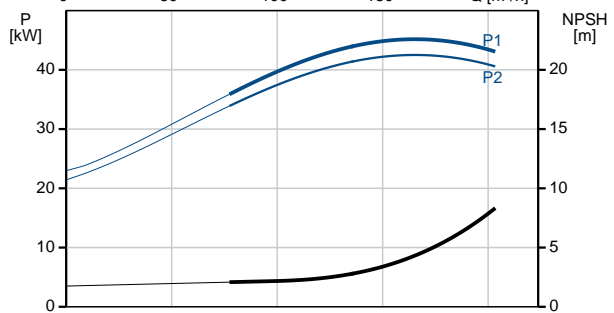
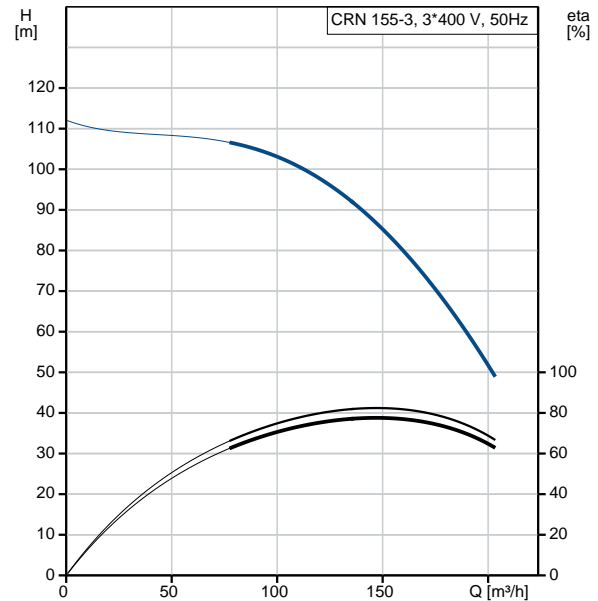



Company name:

Created by:

Phone:

Date:

12/03/2019

Description	Value
Efficiency:	IE3 94,0%
Motor efficiency at full load:	94.0-94.0 %
Motor efficiency at 3/4 load:	94.5-94.5 %
Motor efficiency at 1/2 load:	94.4-94.4 %
Number of poles:	2
Enclosure class (IEC 34-5):	55 Dust/Jetting
Insulation class (IEC 85):	F
Motor protec:	PTC
Motor No:	81U15336
Controls:	
Frequency converter:	NONE
Others:	
Net weight:	517 kg
Gross weight:	635 kg
Shipping volume:	1.44 m ³
Thrust handling device:	N
Approvals:	CE, EAC, ACS, WRAS
Country of origin:	DK
Custom tariff no.:	84137075