

Position	Qty.	Description
	1	<p data-bbox="320 338 651 367">HYDRO MULTI-E 2 CME10-4</p> <div data-bbox="432 389 580 618" style="text-align: center;">  </div> <p data-bbox="711 611 1193 636" style="text-align: center;">Note! Product picture may differ from actual product</p> <p data-bbox="320 642 584 667">Product No.: 99133617</p> <p data-bbox="320 701 1445 754">GRUNDFOS Hydro Multi-E booster sets are designed for the transfer and pressure boosting of clean water in waterworks, blocks of flats, hotels, industry, hospitals, schools, etc.</p> <p data-bbox="320 759 1445 813">GRUNDFOS Hydro Multi-E booster set consists of 2 to 3 CME pumps coupled in parallel and mounted on a common base frame provided with all the necessary fittings.</p> <p data-bbox="320 846 1378 875">Hydro Multi-E is mounted on a common base frame made of stainless steel (DIN W.-Nr. 1.4301).</p> <p data-bbox="320 880 1445 1003">On the suction side are fitted a suction manifold (DIN W.-Nr. 1.4401 or DIN W.-Nr. 1.4571) , a pressure switch mounted on a drainable valve and an isolating valve. On the discharge side of the pumps are fitted a non-return valve, an isolating valve, a pressure gauge, two pressure transmitters mounted on a drainable valve, a diaphragm tank and a stainless steel discharge manifold (DIN W.-Nr. 1.4401 or DIN W.-Nr. 1.4571).</p> <p data-bbox="320 1016 1086 1046">The Hydro Multi-E is fitted with an on/off-switch for the supply voltage.</p> <p data-bbox="320 1077 1398 1131">The Hydro Multi-E is designed for maintaining a constant pressure regardless of flow changes and fluctuation.</p> <p data-bbox="320 1164 1347 1218">The internal PI-controller regulates the number of running pumps and the speed of the pumps according to the required flow.</p> <p data-bbox="320 1252 1458 1305">The system can be operated directly on the panel of any of the pumps or via Grundfos GO (available as accessory)</p> <p data-bbox="320 1339 979 1608">Besides the system features: 2 Digital outputs 2 Digital inputs (one used for dry run protection) 2 Analogue inputs (one used for discharge pressure sensor) Multi-Master functionality 2 Limit functions Set-point influence function Pipe filling function High Efficient PM motors</p> <p data-bbox="320 1639 708 1668">Available communication protocols:</p> <ul data-bbox="320 1673 526 1942" style="list-style-type: none"> •LON •Profibus •Modbus •SMS/GSM/GPRS •GRM •BACnet •BACnet IP •Modbus TCP •PROFINET <p data-bbox="320 1973 1426 2002">When delivered, the GRUNDFOS Hydro Multi-E booster set is factory tested and ready for operation.</p> <p data-bbox="320 2063 405 2092">Liquid:</p>

Position	Qty.	Description
		<p>Pumped liquid: Water</p> <p>Liquid temperature range: 5 .. 60 °C</p> <p>Liquid temperature during operation: 20 °C</p> <p>Density: 998.2 kg/m³</p> <p>Materials:</p> <p>Pump housing: Stainless steel</p> <p>Installation:</p> <p>Maximum operating pressure: 10 bar</p> <p>Maximum inlet pressure: PN 10 bar</p> <p>Flange standard: DIN ISO 7/1</p> <p>Manifold inlet: R 2 1/2</p> <p>Manifold outlet: R 2 1/2</p> <p>Electrical data:</p> <p>IE Efficiency class: IE5</p> <p>Power (P2) main pump: 5.5 kW</p> <p>Mains frequency: 50 Hz</p> <p>Rated voltage: 3 x 380-415 V</p> <p>Rated current: 20.6 A</p> <p>Start. method: electronically</p> <p>Enclosure class (IEC 34-5): IP54</p> <p>Tank:</p> <p>Volume of pressure tank: 12 l</p> <p>Diaphragm tank: Yes</p> <p>Others:</p> <p>Net weight: 144 kg</p> <p>Gross weight: 151 kg</p> <p>Shipping volume: 0.54 m³</p> <p>Language: MULTI</p> <p>Country of origin: GB</p> <p>Custom tariff no.: 84137075</p>

Description	Value
General information:	
Product name:	HYDRO MULTI-E 2 CME10-4
Product No:	99133617
EAN number:	5712607367183
Technical:	
Min flow system:	1 m ³ /h
Max flow:	36 m ³ /h
Head max:	89.6 m
Pump name:	CME10-4
Number of pumps:	2
Materials:	
Pump housing:	Stainless steel
Manifolds:	Stainless steel
Installation:	
Maximum operating pressure:	10 bar
Maximum inlet pressure:	PN 10 bar
Flange standard:	DIN ISO 7/1
Manifold inlet:	R 2 1/2
Manifold outlet:	R 2 1/2
Liquid:	
Pumped liquid:	Water
Liquid temperature range:	5 .. 60 °C
Liquid temperature during operation:	20 °C
Density:	998.2 kg/m ³
Electrical data:	
IE Efficiency class:	IE5
Power (P2) main pump:	5.5 kW
Mains frequency:	50 Hz
Rated voltage:	3 x 380-415 V
Rated current:	20.6 A
Start. method:	electronically
Enclosure class (IEC 34-5):	IP54
Tank:	
Volume of pressure tank:	12 l
Diaphragm tank:	Yes
Others:	
Net weight:	144 kg
Gross weight:	151 kg
Shipping volume:	0.54 m ³
Language:	MULTI
Product range:	International
Country of origin:	GB
Custom tariff no.:	84137075

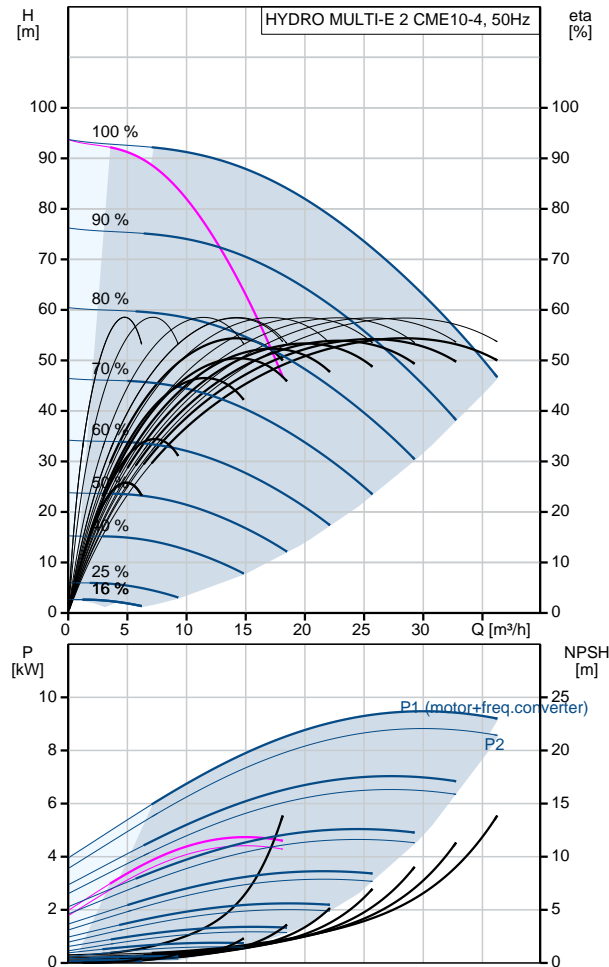

99133617 HYDRO MULTI-E 2 CME10-4 50 Hz

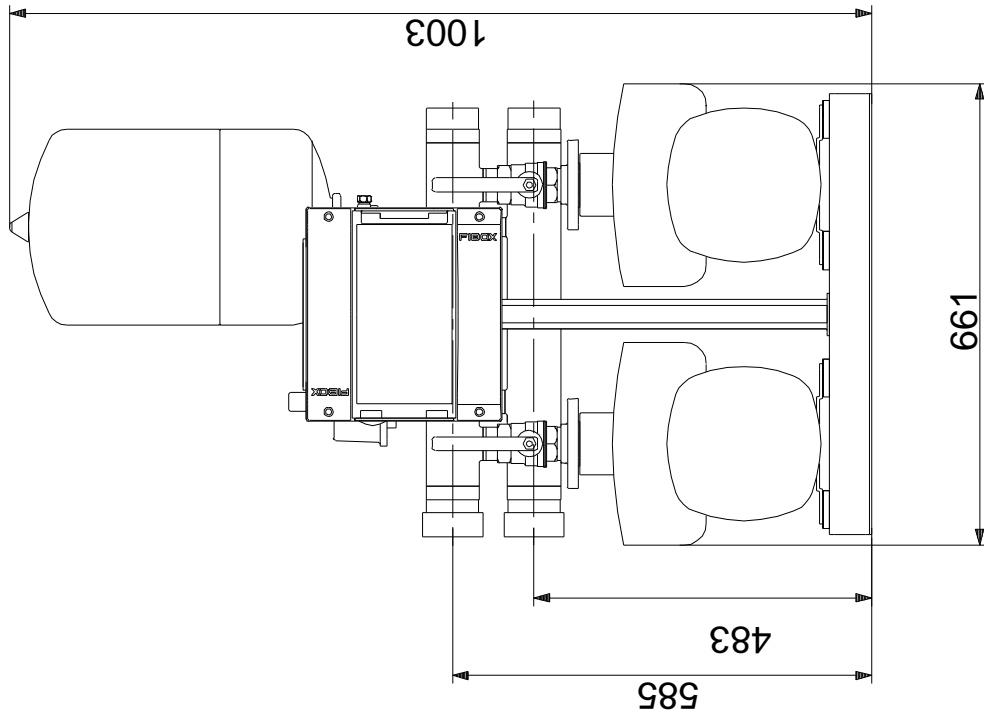
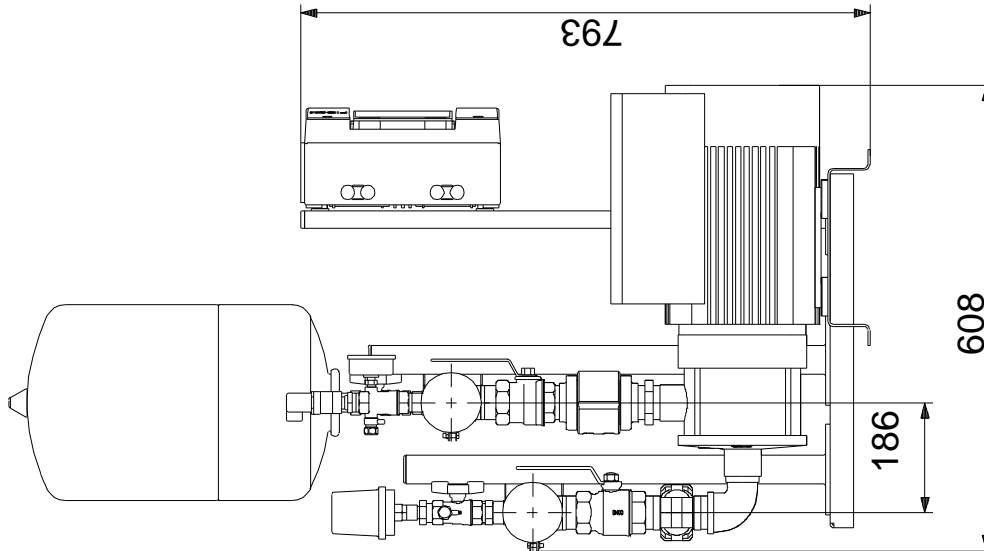

Note! All units are in [mm] unless others are stated.
Disclaimer: This simplified dimensional drawing does not show all details.

99133617 HYDRO MULTI-E 2 CME10-4 50 Hz

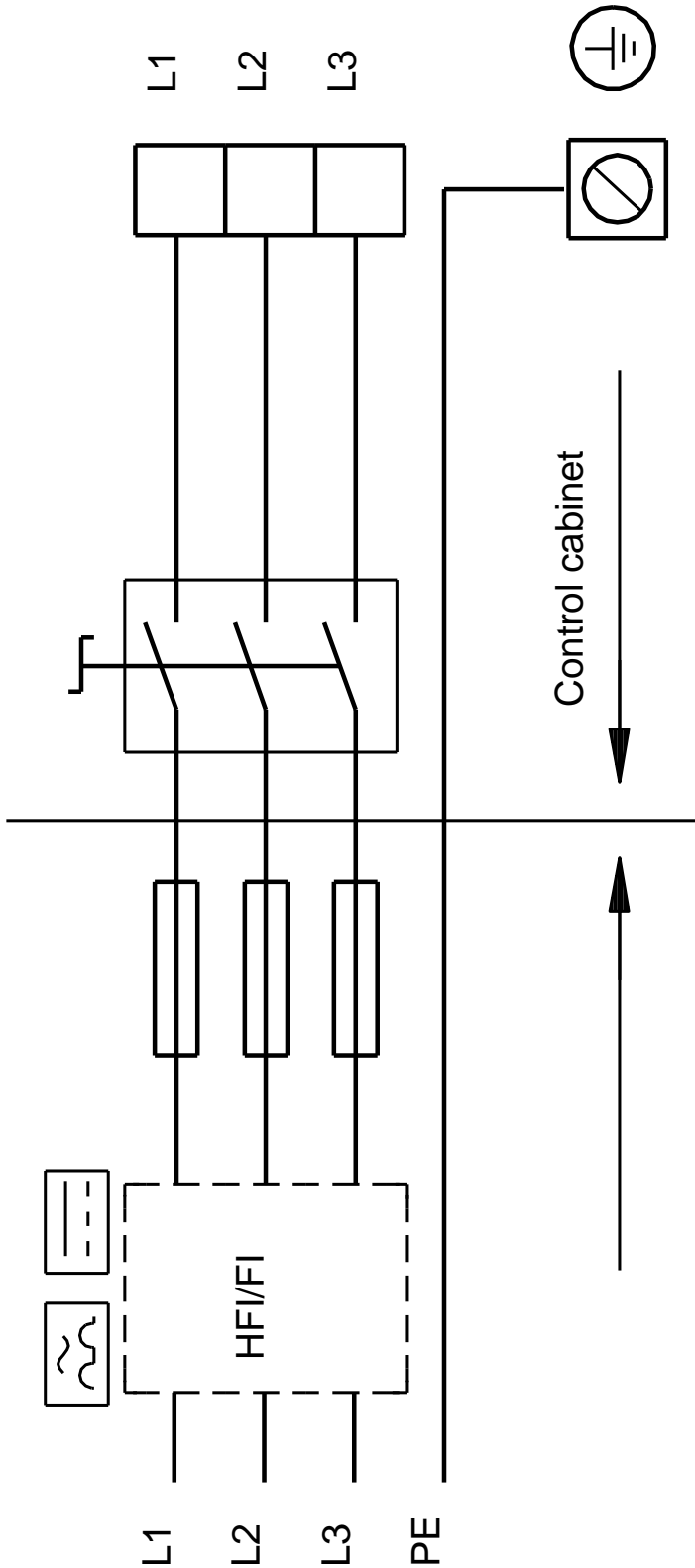

Note! All units are in [mm] unless others are stated.