

Qty. Description

1 TPE 100-110/4 A-F-A-BQQE



Product No.: [99113704](#)

Single-stage, close-coupled, volute pump with in-line suction and discharge ports of identical diameter. The pump is of the top-pull-out design, i.e. the power head (motor, pump head and impeller) can be removed for maintenance or service while the pump housing remains in the pipework.

TPE 100-110/4 A-F-A-BQQE The pump is fitted with an unbalanced rubber bellows seal. TPE 100-110/4 A-F-A-BQQE The shaft seal is according to EN 12756. Pipework connection is via PN 16 DIN flanges (EN 1092-2 and ISO 7005-2).

Pipework connection is via PN 16 DIN flanges (EN 1092-2 and ISO 7005-2).

The pump is fitted with a fan-cooled, permanent-magnet synchronous motor. The motor efficiency is classified as IE5 in accordance with IEC 60034-30-2.

The motor includes a frequency converter and PI controller in the motor terminal box. This enables continuously variable control of the motor speed, which again enables adaptation of the performance to a given requirement.

Further product details

A control panel enables setting of required setpoint as well as setting of pump to "Min." or "Max." operation or to "Stop". The control panel has indicator lights for "Operation" and "Fault".

Communication with the pump is possible by means of the Grundfos GO Remote (accessory). The remote control enables further settings as well as reading out of a number of parameters such as "Actual value", "Speed", "Power input" and total "Power consumption".

An operating panel on the motor terminal box enables setting of required setpoint as well as setting of pump to "Min." or "Max." operation or to "Stop". The Grundfos Eye indicator on the operating panel provides visual indication of pump status:

- "Power on": Motor is running (rotating green indicator lights) or not running (permanently green indicator lights)
- "Warning": Motor is still running (rotating yellow indicator lights) or has stopped (permanently yellow indicator lights)
- "Alarm": Motor has stopped (flashing red indicator lights).

Communication with the pump is possible by means of Grundfos GO Remote (accessory). The remote control enables further settings as well as reading out of a number of parameters such as "Actual value", "Speed", "Power input" and total "Power consumption".

The product's minimum efficiency index (MEI) is greater or equal to 0.70. This is by the Commission Regulation (EU) considered as an indicative benchmark for best-performing water pump available on the market as from 1 January 2013.

Pump

Pump housing and pump head are electrocoated to improve the corrosion resistance.

Electrocoating includes:

- 1) Alkaline-based cleaning.
- 2) Pretreatment with zinc phosphate coating.
- 3) Cathodic electrocoating (epoxy).
- 4) Curing of paint film at 200-250 °C.

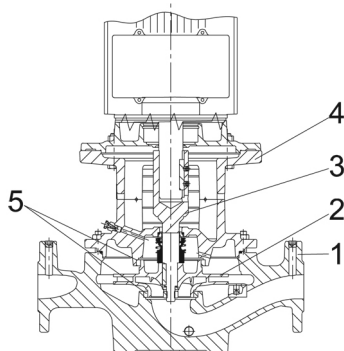

- 1: Pump housing
- 2: Impeller
- 3: Stub shaft
- 4: Pump head/motor stool
- 5: Wear rings

The pump housing is provided with a replaceable brass neck ring to reduce the amount of liquid running from the outlet side of the impeller to the inlet side. The impeller is secured to the shaft with a nut.

The pump is fitted with an unbalanced rubber bellows seal with torque transmission across the spring and around the bellows. Due to the bellows, the seal does not wear the shaft, and the axial movement is not prevented by deposits on the shaft.

Primary seal:

- Rotating seal ring material: silicon carbide (SiC)
- Stationary seat material: silicon carbide (SiC)

This material pairing is used where higher corrosion resistance is required. The high hardness of this material pairing offers good resistance against abrasive particles.

Secondary seal material: EPDM (ethylene-propylene rubber)

EPDM has excellent resistance to hot water. EPDM is not suitable for mineral oils.

A circulation of liquid through the duct of the air vent screw ensures lubrication and cooling of the shaft seal. The flanges have tappings for mounting of pressure gauges.

The motor stool forms connection between the pump housing and the motor, and is equipped with a manual air vent screw for venting of the pump housing and the shaft seal chamber. The sealing between motor stool and pump housing is an O-ring.

The central part of the motor stool is provided with guards for protection against the shaft and coupling. The pump shaft is fastened directly on the motor shaft with key and set screws.

Motor

The motor is a totally enclosed, fan-cooled motor with principal dimensions to IEC and DIN standards. Electrical tolerances comply with IEC 60034.

The motor is flange-mounted with free-hole flange (FF).

Motor-mounting designation in accordance with IEC 60034-7: IM B 5, IM V 1 (Code I) / IM 3001, IM 3011 (Code II).

The motor efficiency is classified as IE5 in accordance with IEC 60034-30-2.

The motor requires no external motor protection. The motor control unit incorporates protection against slow- and quick-rising temperatures, e.g. constant overload and stalled conditions.

TPE 100-110/4 A-F-A-BQQE The terminal box holds terminals for these connections:

- one dedicated digital input
- two analog inputs, 0(4)-20 mA, 0-5 V, 0-10 V, 0.5 - 3.5 V
- 5 V voltage supply to potentiometer and sensor
- one configurable digital input or open-collector output
- Grundfos Digital Sensor input and output

Qty.	Description
	<ul style="list-style-type: none">• 24 V voltage supply for sensors• two signal-relay outputs (potential-free contacts)• GENIbus connection• interface for Grundfos CIM fieldbus module. <p>TPE 100-110/4 A-F-A-BQQE The terminal box holds terminals for these connections:</p> <ul style="list-style-type: none">- one dedicated digital input- two analog inputs, 0(4)-20 mA, 0-5 V, 0-10 V, 0.5 - 3.5 V- 5 V voltage supply to potentiometer and sensor- one configurable digital input or open-collector output- Grundfos Digital Sensor input and output- 24 V voltage supply for sensors- two signal relay outputs (potential-free contacts)- the two power heads communicate via wireless GENIair or wired GENI connection- interface for Grundfos CIM fieldbus module. <p>Technical data</p> <p>Controls: Frequency converter: Built-in</p> <p>Liquid: Pumped liquid: Water Liquid temperature range: -25 .. 120 °C Selected liquid temperature: 20 °C Density at selected liquid temperature: 998.2 kg/m³</p> <p>Technical: Pump speed on which pump data are based: 1455 rpm Rated flow: 85.9 m³/h Rated head: 8.7 m Actual impeller diameter: 177 mm Primary shaft seal: BQQE Curve tolerance: ISO9906:2012 3B</p> <p>Materials: Pump housing: Cast iron EN-JL1040 ASTM A48-40 B Impeller: Cast iron EN-JL1030 ASTM A48-30 B</p> <p>Installation: Range of ambient temperature: -20 .. 50 °C Maximum operating pressure: 16 bar Flange standard: DIN Pipe connection: DN 100 Pressure rating: PN 16 Port-to-port length: 550 mm Flange size for motor: FF215</p> <p>Electrical data: Motor type: 100LD IE Efficiency class: IE5 Rated power - P2: 3 kW Mains frequency: 50 Hz Rated voltage: 3 x 380-500 V Rated current: 5.80-4.60 A</p>



Company name:

Created by:

Phone:

Date:

20/08/2019

Qty.	Description
------	-------------

Cos phi - power factor:	0.91-0.86
Rated speed:	180-2200 rpm
Efficiency:	90.1%
Motor efficiency at full load:	90.1 %
Enclosure class (IEC 34-5):	IP55
Insulation class (IEC 85):	F
Motor No:	98971182

Others:

Minimum efficiency index, MEI $\hat{\alpha}\%$:	0.70
ErP status:	EuP Standalone/Prod.
Net weight:	103 kg
Gross weight:	122 kg
Shipping volume:	0.383 m ³
Danish VVS No.:	382056110
Norwegian NRF no.:	9043656

99113704 TPE 100-110/4 A-F-A-BQQE 50 Hz

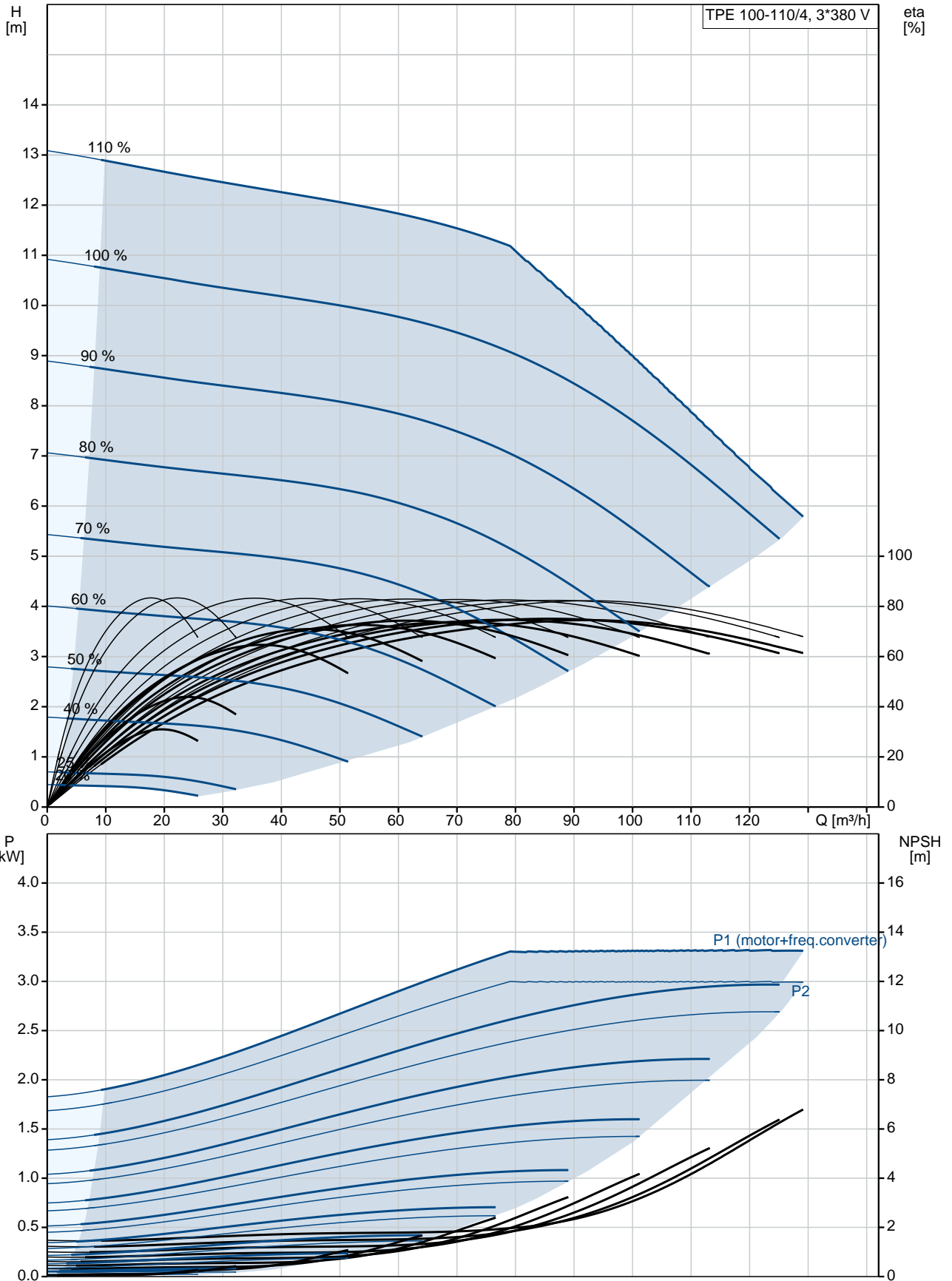

Description	Value
General information:	
Product name:	TPE 100-110/4 A-F-A-BQQE
Product No:	99113704
EAN number:	5712607014674 5712607014674
Technical:	
Pump speed on which pump data are based:	1455 rpm
Rated flow:	85.9 m³/h
Rated head:	8.7 m
Head max:	110 dm
Actual impeller diameter:	177 mm
Primary shaft seal:	BQQE
Curve tolerance:	ISO9906:2012 3B
Pump version:	A
Model:	A
Materials:	
Pump housing:	Cast iron EN-JL1040 ASTM A48-40 B
Impeller:	Cast iron EN-JL1030 ASTM A48-30 B
Material code:	A
Installation:	
Range of ambient temperature:	-20 .. 50 °C
Maximum operating pressure:	16 bar
Flange standard:	DIN
Pipe connection:	DN 100
Pressure rating:	PN 16
Port-to-port length:	550 mm
Flange size for motor:	FF215
Connect code:	F
Liquid:	
Pumped liquid:	Water
Liquid temperature range:	-25 .. 120 °C
Selected liquid temperature:	20 °C
Density at selected liquid temperature:	998.2 kg/m³
Electrical data:	
Motor type:	100LD
IE Efficiency class:	IE5
Rated power - P2:	3 kW
Mains frequency:	50 Hz
Rated voltage:	3 x 380-500 V
Rated current:	5.80-4.60 A
Cos phi - power factor:	0.91-0.86
Rated speed:	180-2200 rpm
Efficiency:	90.1%
Motor efficiency at full load:	90.1 %
Enclosure class (IEC 34-5):	IP55
Insulation class (IEC 85):	F
Motor protec:	YES
Motor No:	98971182
Controls:	
Control panel:	HMI200 - Standard
Function Module:	FM300 - Advanced
Frequency converter:	Built-in
Others:	

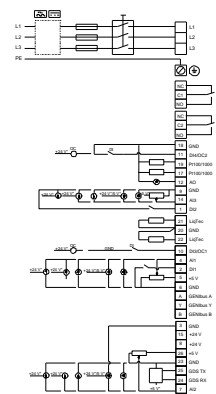
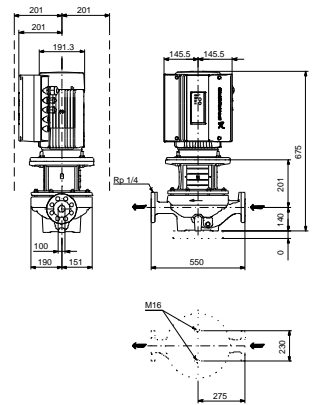
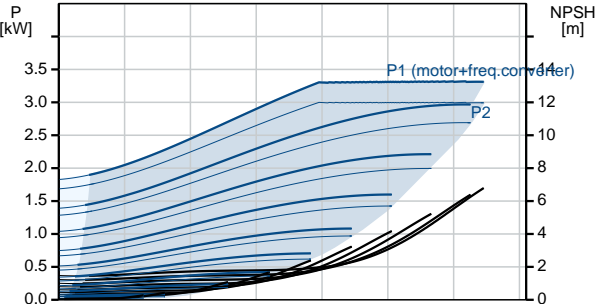
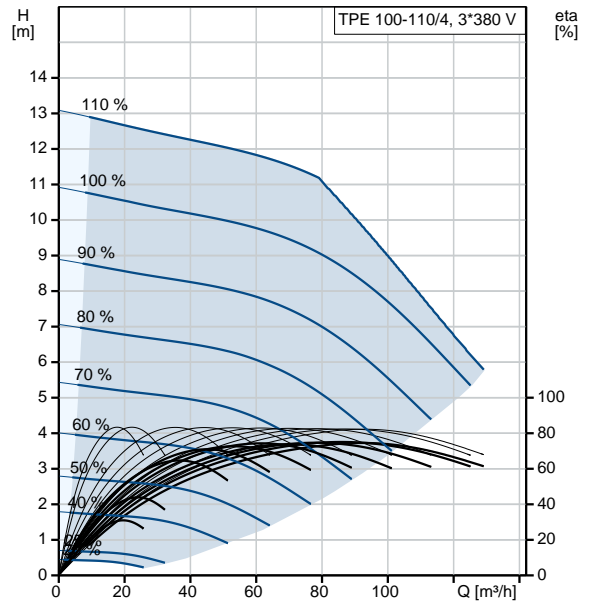



Company name:

Created by:

Phone:

Date:

20/08/2019

Description	Value
Minimum efficiency index, MEI â%¥:	0.70
ErP status:	EuP Standalone/Prod.
Net weight:	103 kg
Gross weight:	122 kg
Shipping volume:	0.383 m³
Config. file no:	99100730
Danish VVS No.:	382056110
Norwegian NRF no.:	9043656

99113704 TPE 100-110/4 A-F-A-BQQE 50 Hz

