

Position	Qty.	Description
	1	<p>TP 100-120/2 B AI-F-Z-BQQE</p>  <p>Note! Product picture may differ from actual product</p> <p>Product No.: 98958086</p> <p>Single-stage, close-coupled, volute pump with in-line suction and discharge ports of identical diameter. The pump is of the top-pull-out design, i.e. the power head (motor, pump head and impeller) can be removed for maintenance or service while the pump housing remains in the pipework.</p> <p>The pump is fitted with an unbalanced rubber bellows seal. The shaft seal is according to EN 12756. Pipework connection is via PN 6 DIN flanges (EN 1092-2 and ISO 7005-2).</p> <p>The pump is fitted with a fan-cooled asynchronous motor.</p> <p>Liquid: Pumped liquid: Water Liquid temperature range: -25 .. 120 °C Liquid temperature during operation: 20 °C Density: 998.2 kg/m³</p> <p>Technical: Speed for pump data: 2910 rpm Rated flow: 72.8 m³/h Rated head: 7.8 m Primary shaft seal: BQQE Curve tolerance: ISO9906:2012 3B</p> <p>Materials: Pump housing: Bronze DIN W.-Nr. 2.1050 ASTM B505-C90700 Impeller: Stainless steel DIN W.-Nr. 1.4301 AISI 304</p> <p>Installation: Range of ambient temperature: -30 .. 60 °C Maximum operating pressure: 6 bar Flange standard: DIN Pipe connection: DN 100 Pressure stage: PN 6 Port-to-port length: 450 mm Flange size for motor: FT115</p> <p>Electrical data: Motor type: 90LC IE Efficiency class: IE3 Rated power - P2: 2.2 kW Power (P2) required by pump: 2.2 kW Mains frequency: 50 Hz Rated voltage: 3 x 220-240D/380-415Y V</p>

Position	Qty.	Description
		<p>Rated current: 7,70/4,45 A</p> <p>Starting current: 850-950 %</p> <p>Cos phi - power factor: 0,89-0,87</p> <p>Rated speed: 2890-2910 rpm</p> <p>Efficiency: IE3 85,9%</p> <p>Motor efficiency at full load: 85.9 %</p> <p>Motor efficiency at 3/4 load: 86.8 %</p> <p>Motor efficiency at 1/2 load: 86.0 %</p> <p>Number of poles: 2</p> <p>Enclosure class (IEC 34-5): 55 Dust/Jetting</p> <p>Insulation class (IEC 85): F</p> <p>Others:</p> <p>Label: Grundfos Blueflux</p> <p>Minimum efficiency index, MEI : 0.70</p> <p>ErP status: EuP Standalone/Prod.</p> <p>Net weight: 65.9 kg</p> <p>Gross weight: 72.5 kg</p> <p>Shipping volume: 0.16 m³</p>

98958086 TP 100-120/2 B 50 Hz

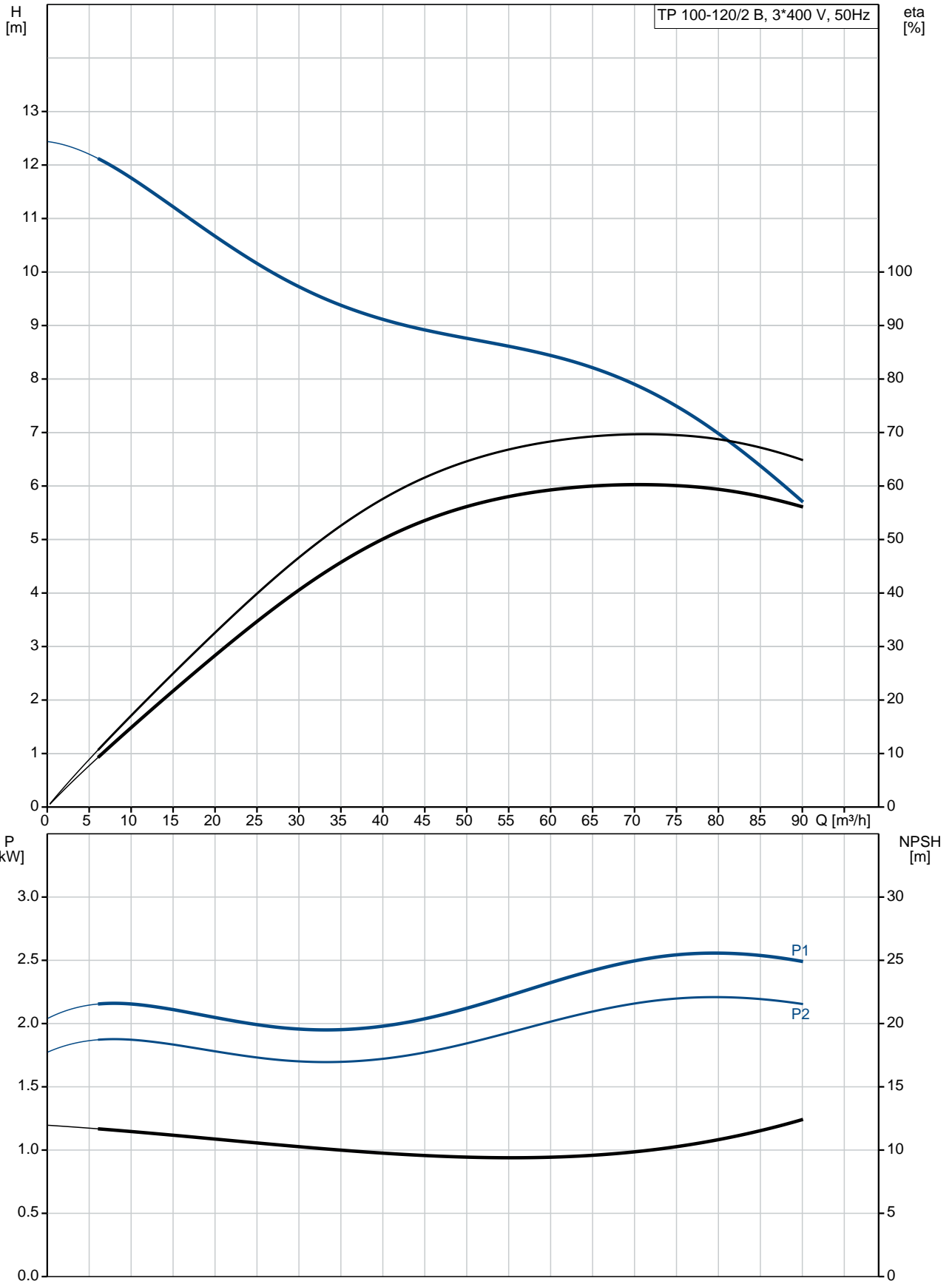

Description	Value
General information:	
Product name:	TP 100-120/2 B AI-F-Z-BQQE
Product No:	98958086
EAN number:	5712604245538
Technical:	
Speed for pump data:	2910 rpm
Rated flow:	72.8 m ³ /h
Rated head:	7.8 m
Head max:	120 dm
Primary shaft seal:	BQQE
Curve tolerance:	ISO9906:2012 3B
Pump version:	AI
Model:	A
Materials:	
Pump housing:	Bronze DIN W.-Nr. 2.1050 ASTM B505-C90700
Impeller:	Stainless steel DIN W.-Nr. 1.4301 AISI 304
Material code:	Z
Installation:	
Range of ambient temperature:	-30 .. 60 °C
Maximum operating pressure:	6 bar
Flange standard:	DIN
Connect code:	F
Pipe connection:	DN 100
Pressure stage:	PN 6
Port-to-port length:	450 mm
Flange size for motor:	FT115
Liquid:	
Pumped liquid:	Water
Liquid temperature range:	-25 .. 120 °C
Liquid temperature during operation:	20 °C
Density:	998.2 kg/m ³
Electrical data:	
Motor type:	90LC
IE Efficiency class:	IE3
Rated power - P2:	2.2 kW
Power (P2) required by pump:	2.2 kW
Mains frequency:	50 Hz
Rated voltage:	3 x 220-240D/380-415Y V
Rated current:	7,70/4,45 A
Starting current:	850-950 %
Cos phi - power factor:	0,89-0,87
Rated speed:	2890-2910 rpm
Efficiency:	IE3 85,9%
Motor efficiency at full load:	85.9 %
Motor efficiency at 3/4 load:	86.8 %
Motor efficiency at 1/2 load:	86.0 %
Number of poles:	2
Enclosure class (IEC 34-5):	55 Dust/Jetting
Insulation class (IEC 85):	F

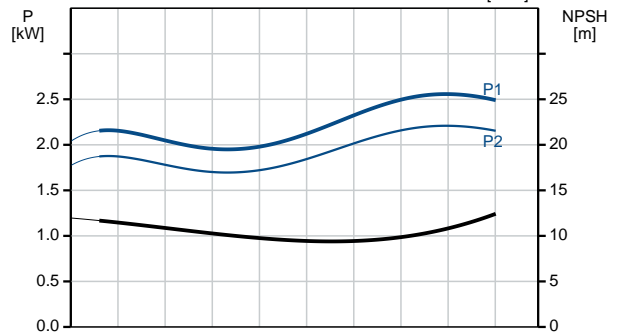
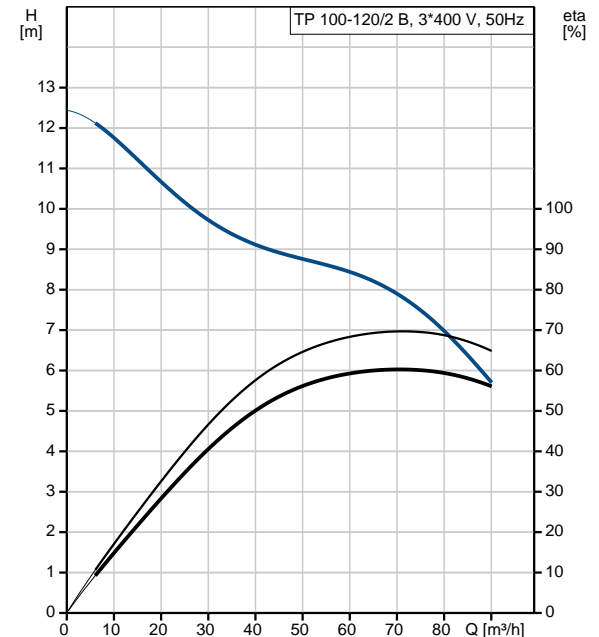



Company name:

Created by:

Phone:

Date:

30/06/2017

Description	Value
Motor protec:	NONE
Motor No:	85U05908
Others:	
Label:	Grundfos Blueflux
Minimum efficiency index, MEI :	0.70
ErP status:	EuP Standalone/Prod.
Net weight:	65.9 kg
Gross weight:	72.5 kg
Shipping volume:	0.16 m ³

98958086 TP 100-120/2 B 50 Hz

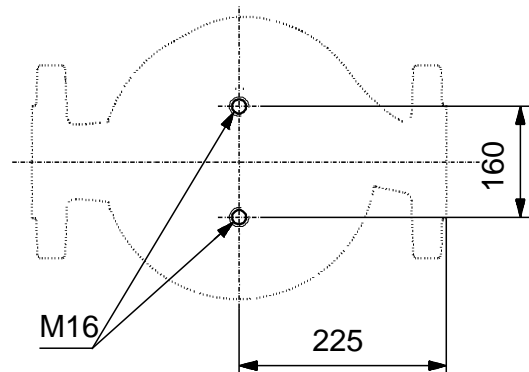
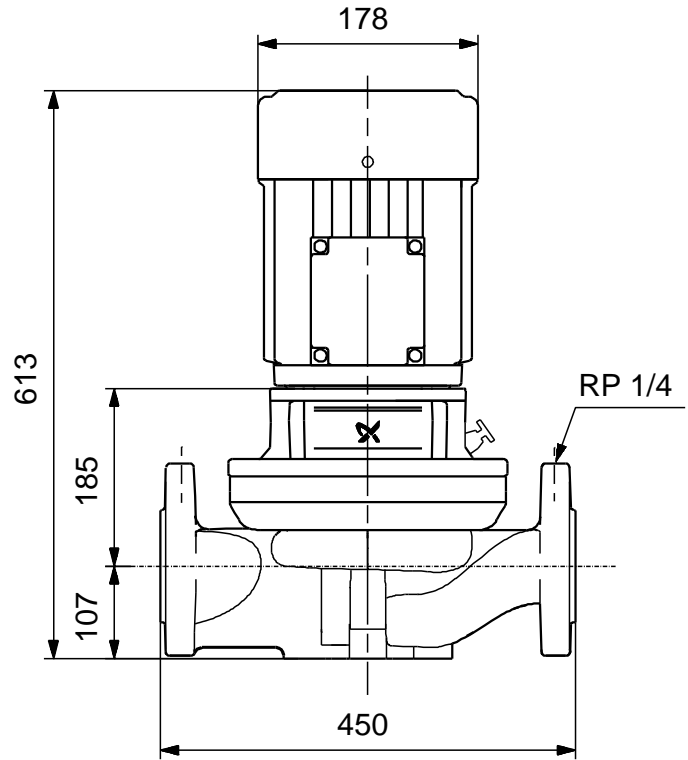
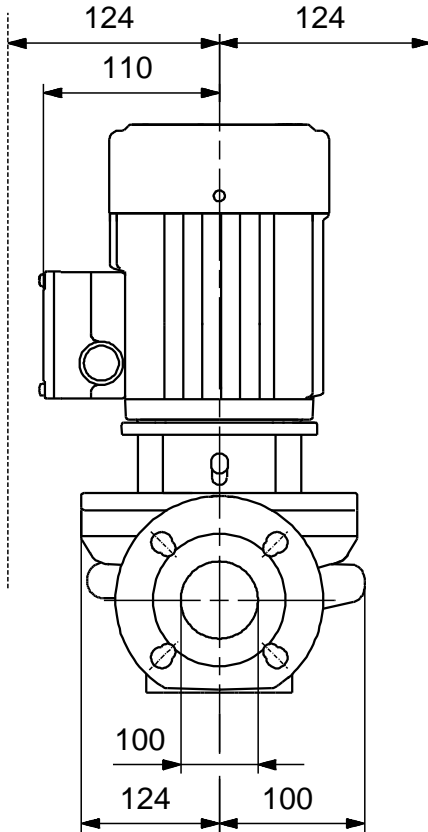

Note! All units are in [mm] unless others are stated.
Disclaimer: This simplified dimensional drawing does not show all details.

98958086 TP 100-120/2 B 50 Hz



Note! All units are in [mm] unless others are stated.