

Qty. Description

1 MTR 8-4/4 A-W-A-HUUV



Product No.: [98825618](#)

Multistage, immersible, self-priming, centrifugal pump for vertical installation in tanks etc. The pump head and base are in cast iron – all other wetted parts are in stainless steel.

The pump has the following characteristics:

- Installation length according to DIN 5440.
- Impellers, intermediate chambers and spline shaft are made of Stainless steel.
- Mechanical shaft seal according to EN 12756.
- Power transmission via cast-iron split coupling.

A cartridge shaft seal ensures high reliability, safe handling, and easy access and service. The pump is fitted with a 3-phase, fan-cooled asynchronous motor.

Controls:

Frequency converter: NONE

Liquid:

Pumped liquid: Water
 Liquid temperature range: -10 .. 90 °C
 Selected liquid temperature: 20 °C
 Density at selected liquid temperature: 998.2 kg/m³

Technical:

Pump speed on which pump data are based: 2900 rpm
 Rated flow: 8 m³/h
 Rated head: 31.7 m
 Chambers: 4
 Drainage back to tank: N
 Pump orientation: Vertical
 Code for shaft seal: HUUV
 Curve tolerance: ISO9906:2012 3B

Materials:

Pump head: Cast iron
 EN 1561 EN-GJL-200
 ASTM A48-25B
 Impeller: Stainless steel
 EN 1.4301
 AISI 304

Installation:

Maximum ambient temperature: 60 °C
 Maximum operating pressure: 25 bar
 Max pressure at stated temp: 25 bar / 90 °C
 Type of connection: G
 Size of outlet connection: 1 1/4 inch

Qty.	Description
	<p>Immersion depth: 277 mm</p> <p>Flange size for motor: FT115</p> <p>Electrical data:</p> <p>Motor standard: IEC</p> <p>Motor type: 90SB</p> <p>IE Efficiency class: IE3</p> <p>Rated power - P2: 1.5 kW</p> <p>Mains frequency: 50 Hz</p> <p>Rated voltage: 3 x 220-240D/380-415Y V</p> <p>Rated current: 5.45/3.15 A</p> <p>Starting current: 850-930 %</p> <p>Cos phi - power factor: 0.87-0.82</p> <p>Rated speed: 2890-2910 rpm</p> <p>Efficiency: IE3 84,2%</p> <p>Motor efficiency at full load: 84.2 %</p> <p>Motor efficiency at 3/4 load: 84.5 %</p> <p>Motor efficiency at 1/2 load: 83.1 %</p> <p>Number of poles: 2</p> <p>Enclosure class (IEC 34-5): 55 Dust/Jetting</p> <p>Insulation class (IEC 85): F</p> <p>Motor No: 85U05906</p> <p>Others:</p> <p>Terminal box position: 6</p> <p>Minimum efficiency index, MEI : 0.70</p> <p>Net weight: 29.5 kg</p> <p>Gross weight: 32.9 kg</p> <p>Shipping volume: 0.06 m³</p> <p>Country of origin: HU</p> <p>Custom tariff no.: 84137075</p>

98825618 MTR 8-4/4 A-W-A-HUUV 50 Hz

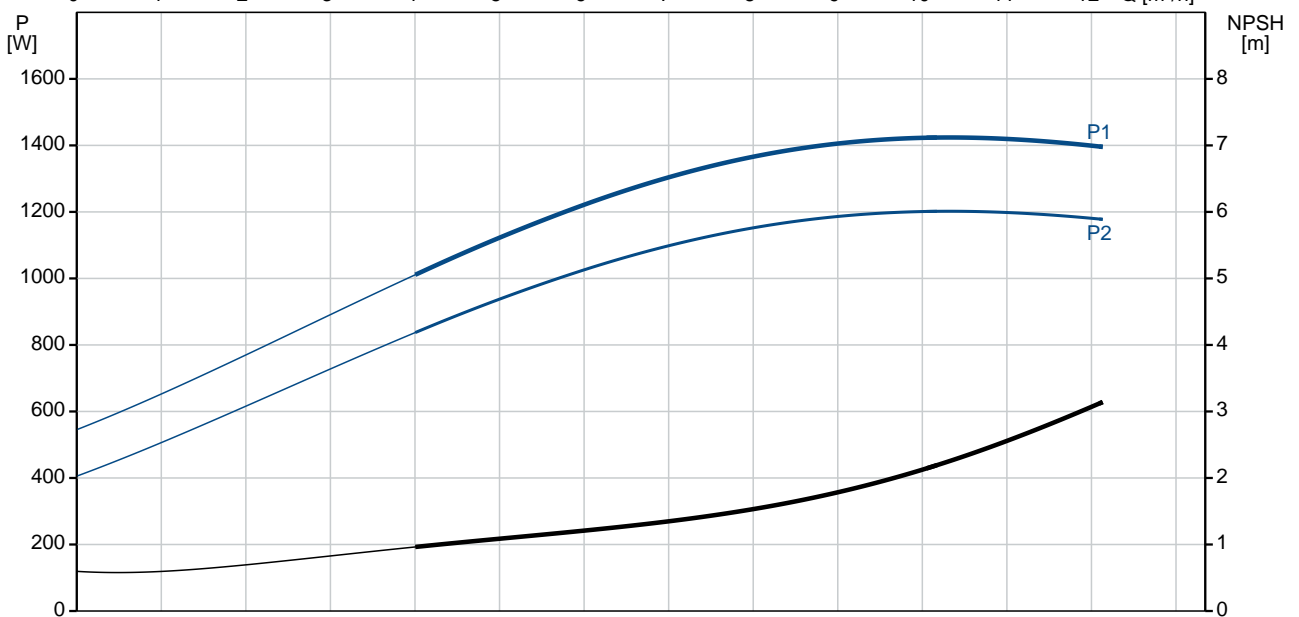
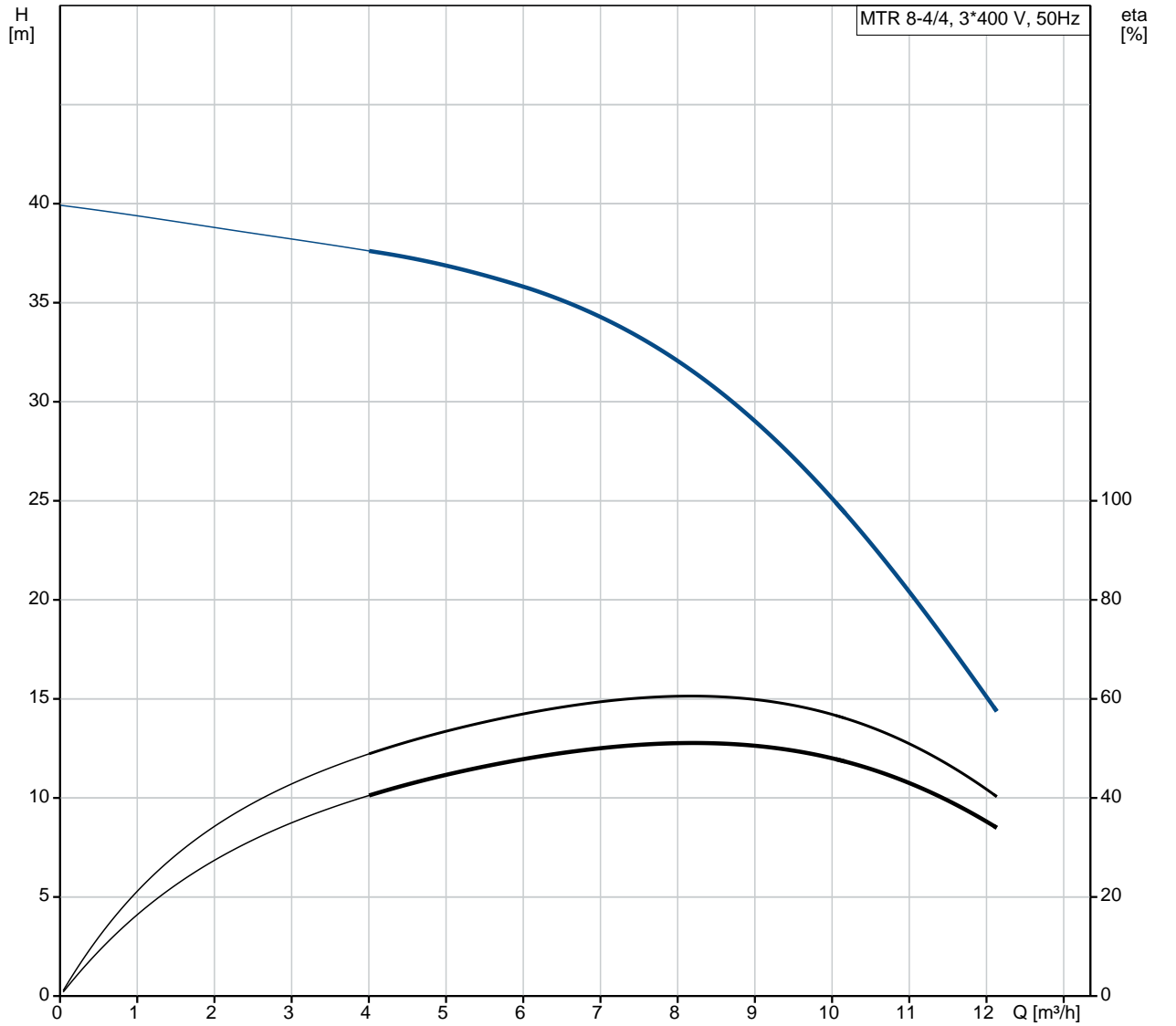

Description	Value
General information:	
Product name:	MTR 8-4/4 A-W-A-HUUV
Product No:	98825618
EAN number:	5712601937924 5712601937924
Price:	1.224,00 GBP
Technical:	
Pump speed on which pump data are based:	2900 rpm
Rated flow:	8 m ³ /h
Rated head:	31.7 m
Chambers:	4
Impellers:	4
Number of reduced-diameter impellers:	0
Drainage back to tank:	N
Pump orientation:	Vertical
Code for shaft seal:	HUUV
Curve tolerance:	ISO9906:2012 3B
Pump version:	A
Model:	A
Materials:	
Pump head:	Cast iron EN 1561 EN-GJL-200 ASTM A48-25B
Impeller:	Stainless steel EN 1.4301 AISI 304
Material code:	A
Installation:	
Maximum ambient temperature:	60 °C
Maximum operating pressure:	25 bar
Max pressure at stated temp:	25 bar / 90 °C
Type of connection:	G
Size of outlet connection:	1 1/4 inch
Immersion depth:	277 mm
Flange size for motor:	FT115
Connect code:	W
Liquid:	
Pumped liquid:	Water
Liquid temperature range:	-10 .. 90 °C
Selected liquid temperature:	20 °C
Density at selected liquid temperature:	998.2 kg/m ³
Electrical data:	
Motor standard:	IEC
Motor type:	90SB
IE Efficiency class:	IE3
Rated power - P2:	1.5 kW
Mains frequency:	50 Hz
Rated voltage:	3 x 220-240D/380-415Y V
Rated current:	5.45/3.15 A
Starting current:	850-930 %
Cos phi - power factor:	0.87-0.82
Rated speed:	2890-2910 rpm
Efficiency:	IE3 84,2%
Motor efficiency at full load:	84.2 %
Motor efficiency at 3/4 load:	84.5 %
Motor efficiency at 1/2 load:	83.1 %

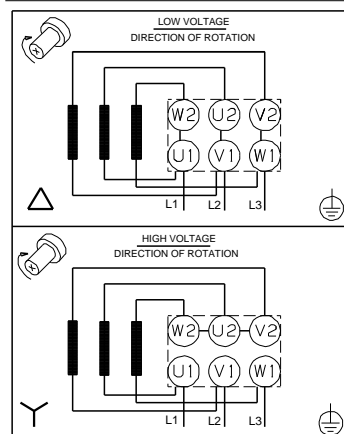
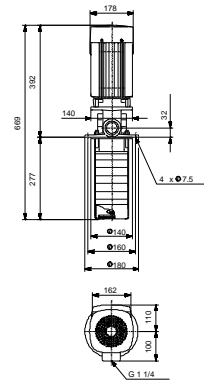
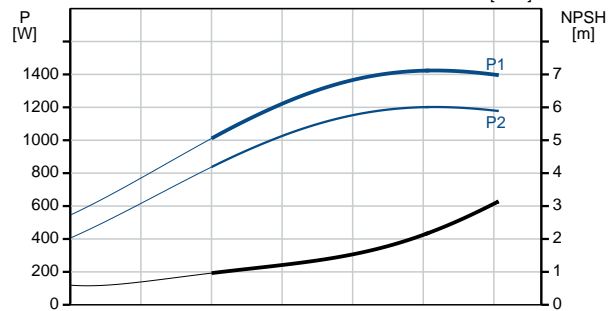
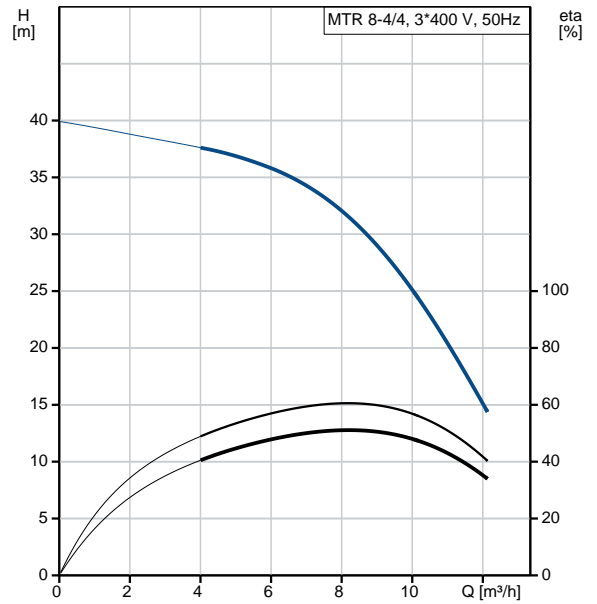



Company name:

Created by:

Phone:

Date:

15/10/2019

Description	Value
Number of poles:	2
Enclosure class (IEC 34-5):	55 Dust/Jetting
Insulation class (IEC 85):	F
Motor protec:	NONE
Motor No:	85U05906
Controls:	
Frequency converter:	NONE
Others:	
Terminal box position:	6
Minimum efficiency index, MEI :	0.70
Net weight:	29.5 kg
Gross weight:	32.9 kg
Shipping volume:	0.06 m ³
Country of origin:	HU
Custom tariff no.:	84137075

98825618 MTR 8-4/4 A-W-A-HUUV 50 Hz

