

Qty.	Description
1	<p data-bbox="199 336 534 369">NB 40-125/139 ASF2ABQQE</p> <div data-bbox="215 403 566 638">  </div> <p data-bbox="590 627 1077 660" style="text-align: center;">Note! Product picture may differ from actual product</p> <p data-bbox="199 660 470 694">Product No.: 98810277</p> <p data-bbox="199 716 1460 772">Non-self-priming, single-stage, centrifugal volute pump designed according to ISO 5199 with dimensions and rated performance according to EN 733 (10 bar).</p> <p data-bbox="199 806 1452 884">Flanges are PN 16 with dimensions according to EN 1092-2. The pump has an axial suction port, radial discharge port, horizontal shaft and a back pull-out design enabling removal of the motor, motor stool, cover and impeller without disturbing the pump housing or pipework.</p> <p data-bbox="199 896 941 929">The unbalanced rubber bellows seal is according to DIN EN 12756.</p> <p data-bbox="199 929 909 963">The pump is close-coupled to a fan-cooled asynchronous motor.</p> <p data-bbox="199 985 319 1019">Controls:</p> <p data-bbox="199 1019 638 1052">Frequency converter: NONE</p> <p data-bbox="199 1075 295 1108">Liquid:</p> <p data-bbox="199 1108 638 1142">Pumped liquid: Water</p> <p data-bbox="199 1142 710 1176">Liquid temperature range: -25 .. 120 °C</p> <p data-bbox="199 1176 694 1209">Liquid temperature during operation: 20 °C</p> <p data-bbox="199 1209 702 1243">Density: 998.2 kg/m³</p> <p data-bbox="199 1254 327 1288">Technical:</p> <p data-bbox="199 1288 678 1321">Rated flow: 44.4 m³/h</p> <p data-bbox="199 1321 646 1355">Rated head: 21.7 m</p> <p data-bbox="199 1355 662 1388">Actual impeller diameter: 139 mm</p> <p data-bbox="199 1388 662 1422">Nominal impeller diameter: 125 mm</p> <p data-bbox="199 1422 638 1456">Shaft seal arrangement: Single</p> <p data-bbox="199 1456 638 1489">Code for shaft seal: BQQE</p> <p data-bbox="199 1489 766 1523">Curve tolerance: ISO9906:2012 3B</p> <p data-bbox="199 1534 327 1568">Materials:</p> <p data-bbox="199 1568 742 1646">Pump housing: Cast iron EN-GJL-250 ASTM class 35</p> <p data-bbox="199 1646 638 1680">Wear ring: Brass</p> <p data-bbox="199 1680 742 1758">Impeller: Cast iron EN-GJL-200 ASTM class 30</p> <p data-bbox="199 1758 734 1848">Shaft: Stainless steel EN 1.4301 AISI 304</p> <p data-bbox="199 1881 343 1915">Installation:</p> <p data-bbox="199 1915 630 1948">Maximum ambient temperature: 60 °C</p> <p data-bbox="199 1948 646 1982">Maximum operating pressure: 16 bar</p> <p data-bbox="199 1982 694 2016">Pipe connection standard: EN 1092-2</p> <p data-bbox="199 2016 638 2049">Size of inlet connection: DN 65</p> <p data-bbox="199 2049 638 2083">Size of outlet connection: DN 40</p> <p data-bbox="199 2083 694 2116">Pressure rating for pipe connection: PN 16</p> <p data-bbox="199 2116 582 2150">Pump housing with feet: Y</p>

Qty.	Description
	<p>Support block: Y</p> <p>Electrical data:</p> <p>IE Efficiency class: IE3</p> <p>P2: 4 kW</p> <p>Mains frequency: 50 Hz</p> <p>Rated voltage: 3 x 380-415D V</p> <p>Rated current: 7.9 A</p> <p>Starting current: 1000-1110 %</p> <p>Cos phi - power factor: 0.87-0.87</p> <p>Rated speed: 2920-2940 rpm</p> <p>Efficiency: IE3 88,1%</p> <p>Motor efficiency at full load: 88.1 %</p> <p>Motor efficiency at 3/4 load: 88.6 %</p> <p>Motor efficiency at 1/2 load: 85.2 %</p> <p>Number of poles: 2</p> <p>Enclosure class (IEC 34-5): 55 Dust/Jetting</p> <p>Insulation class (IEC 85): F</p> <p>Others:</p> <p>Minimum efficiency index, MEI $\hat{\alpha}\%$: 0.70</p> <p>Net weight: 67 kg</p> <p>Gross weight: 77 kg</p> <p>Shipping volume: 0.178 m³</p> <p>Country of origin: HU</p> <p>Custom tariff no.: 84137051</p>

98810277 NB 40-125/139 ASF2ABQQE 50 Hz

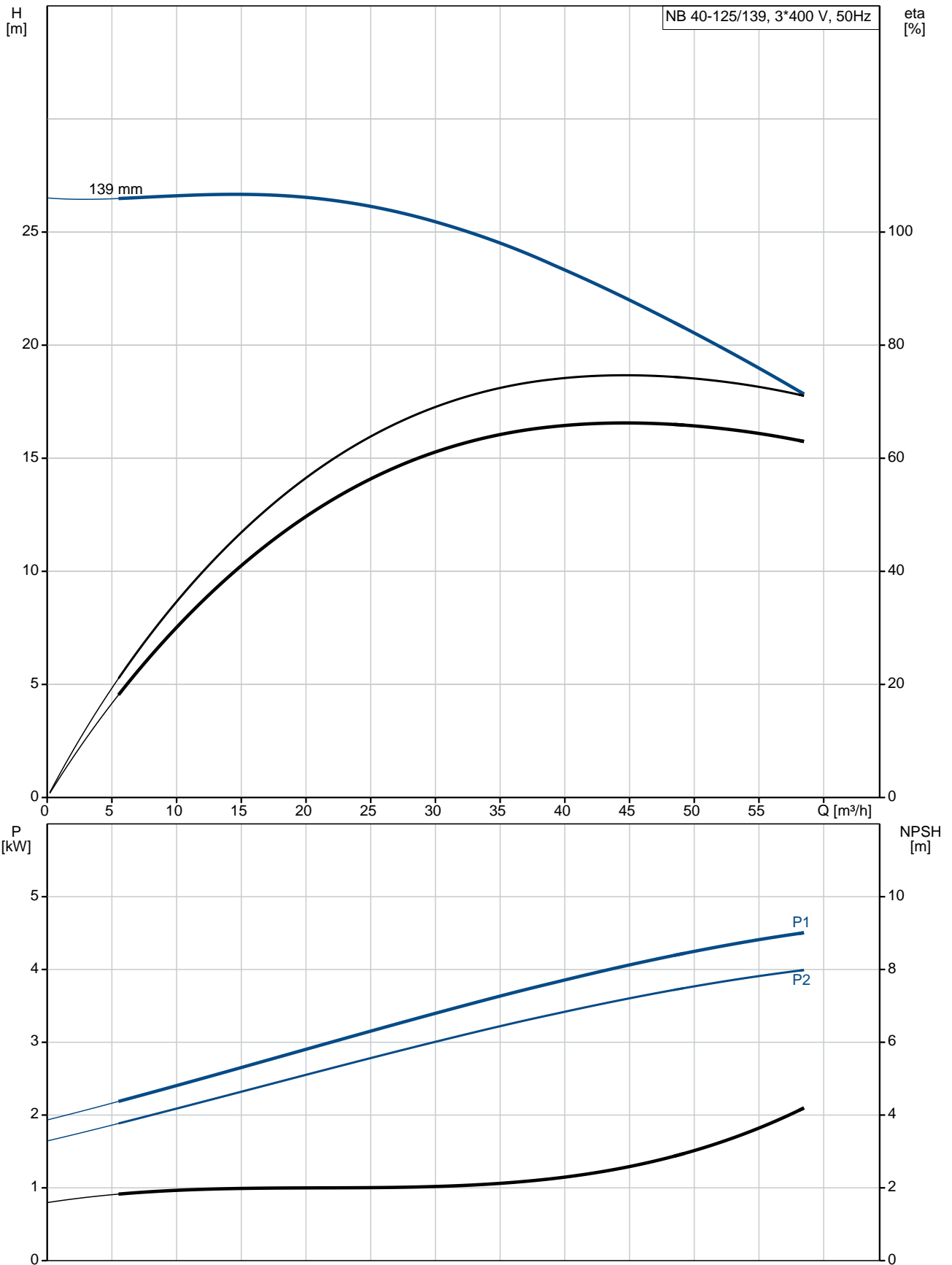

Description	Value
-------------	-------

General information:

Product name: NB 40-125/139 ASF2ABQQE

Product No: [98810277](#)

EAN number: 5712601679114

Price: 1.843,00 GBP

Technical:

Rated flow: 44.4 m³/h

Rated head: 21.7 m

Actual impeller diameter: 139 mm

Nominal impeller diameter: 125 mm

Shaft seal arrangement: Single

Shaft diameter: 24 mm

Code for shaft seal: BQQE

Curve tolerance: ISO9906:2012 3B

Pump version: AS

Materials:

Pump housing: Cast iron

EN-GJL-250

ASTM class 35

Wear ring: Brass

Impeller: Cast iron

EN-GJL-200

ASTM class 30

Shaft: Stainless steel

EN 1.4301

AISI 304

Material code: A

Installation:

Maximum ambient temperature: 60 °C

Maximum operating pressure: 16 bar

Pipe connection standard: EN 1092-2

Size of inlet connection: DN 65

Size of outlet connection: DN 40

Pressure rating for pipe connection: PN 16

Pump housing with feet: Y

Support block: Y

Connect code: F2

Liquid:

Pumped liquid: Water

Liquid temperature range: -25 .. 120 °C

Liquid temperature during operation: 20 °C

Density: 998.2 kg/m³

Electrical data:

IE Efficiency class: IE3

P2: 4 kW

Mains frequency: 50 Hz

Rated voltage: 3 x 380-415D V

Rated current: 7.9 A

Starting current: 1000-1110 %

Cos phi - power factor: 0.87-0.87

Rated speed: 2920-2940 rpm

Efficiency: IE3 88,1%

Motor efficiency at full load: 88.1 %

Motor efficiency at 3/4 load: 88.6 %

Motor efficiency at 1/2 load: 85.2 %

Number of poles: 2

Enclosure class (IEC 34-5): 55 Dust/Jetting

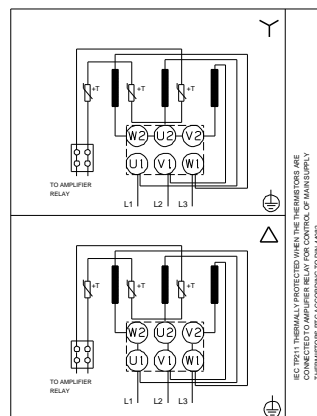
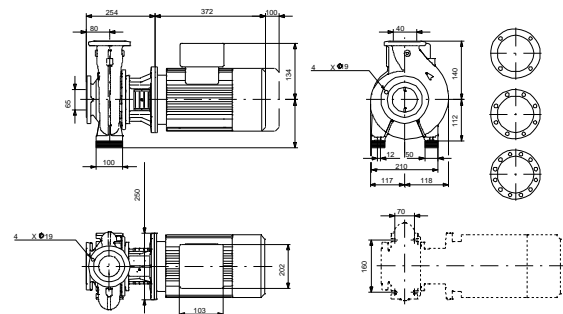
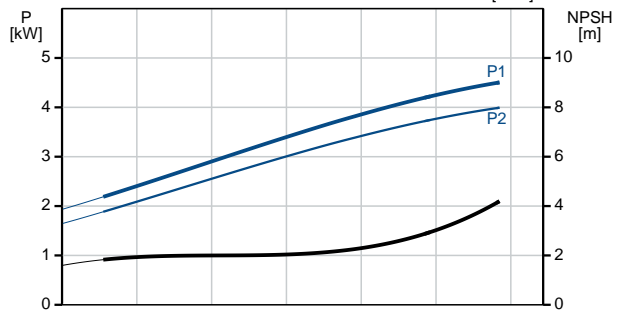
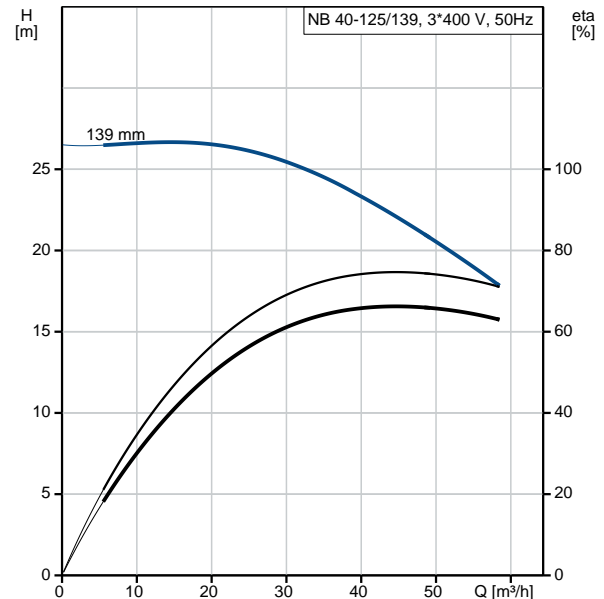

IEC 7014 TERMINALS INDICATED IN THE DRAWINGS ARE CONNECTED TO AMPLIFIER RELAY FOR CONTROL OF MAIN SUPPLY. TERMINALS ARE FITTED ACCORDING TO DIN 46202.



Company name:

Created by:

Phone:

Date:

21/03/2019

Description	Value
Insulation class (IEC 85):	F
Motor protec:	PTC
Motor No:	87322303
Mount. design. acc. IEC 34-7:	IM V1/B5
Controls:	
Frequency converter:	NONE
Others:	
Minimum efficiency index, MEI $\eta_{\%}$:	0.70
Net weight:	67 kg
Gross weight:	77 kg
Shipping volume:	0.178 m ³
Country of origin:	HU
Custom tariff no.:	84137051

98810277 NB 40-125/139 ASF2ABQQE 50 Hz

