

Qty. Description

1 SPK 4-15/15 A-W-A-AUUV



Note! Product picture may differ from actual product

Product No.: [98776578](#)

Multistage, immersible, self-priming, centrifugal pump for vertical and horizontal installation in tanks etc.

The pump has the following characteristics:

- Installation length according to DIN 5440.
- Impellers, intermediate chambers and spline shaft are made of stainless steel and motor stool of GG 20.
- Mechanical shaft seal according to EN 12756.
- Power transmission via cast iron split coupling.

The motor is a 3-phase AC motor.

Immersion depth: 434 mm

Liquid:

Pumped liquid: Water
Liquid temperature range: -10 .. 90 °C
Selected liquid temperature: 20 °C
Density at selected liquid temperature: 998.2 kg/m³

Technical:

Pump speed on which pump data are based: 2853 rpm
Rated flow: 4 m³/h
Rated head: 47.8 m
Primary shaft seal: AUUV
Curve tolerance: ISO9906:2012 3B
Drain holes: Open drain hole

Materials:

Pump head: Cast iron
EN-GJL-200
ASTM 25B
Impeller: Stainless steel
DIN W.-Nr. 1.4301
AISI 304

Installation:

Maximum ambient temperature: 60 °C
Pipe connection: G 3/4
Flange size for motor: FT100

Electrical data:

Motor type: 80C
IE Efficiency class: IE3

Qty.	Description
------	-------------

Rated power - P2:	1.1 kW
Power (P2) required by pump:	1.1 kW
Mains frequency:	50 Hz
Rated voltage:	3 x 220-240D/380-415Y V
Rated current:	4.35/2.50 A
Starting current:	450-500 %
Cos phi - power factor:	0.83-0.76
Rated speed:	2840-2870 rpm
Efficiency:	IE3 82,7%
Motor efficiency at full load:	82.7 %
Motor efficiency at 3/4 load:	84.6 %
Motor efficiency at 1/2 load:	85.4 %
Number of poles:	2
Enclosure class (IEC 34-5):	55 Dust/Jetting
Insulation class (IEC 85):	F
Motor No:	85U05105

Others:

Minimum efficiency index, MEI :	N/A
Net weight:	16.3 kg
Gross weight:	17.6 kg
Country of origin:	HU
Custom tariff no.:	84137075

98776578 SPK 4-15/15 A-W-A-AUUV 50 Hz

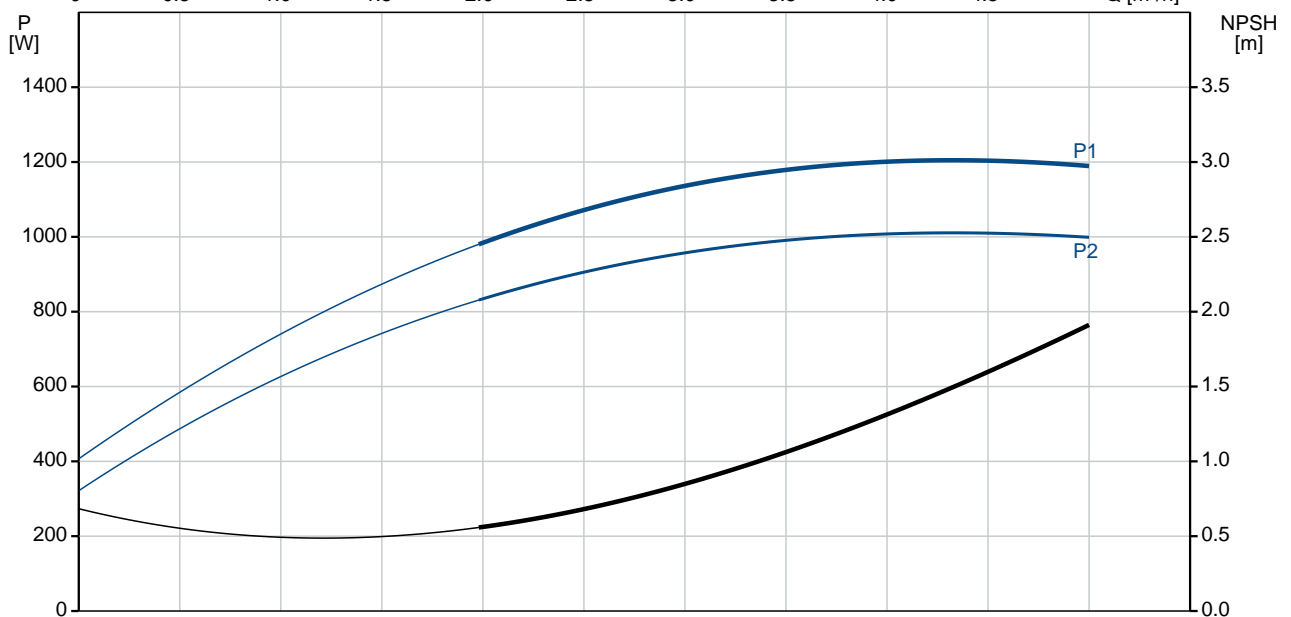
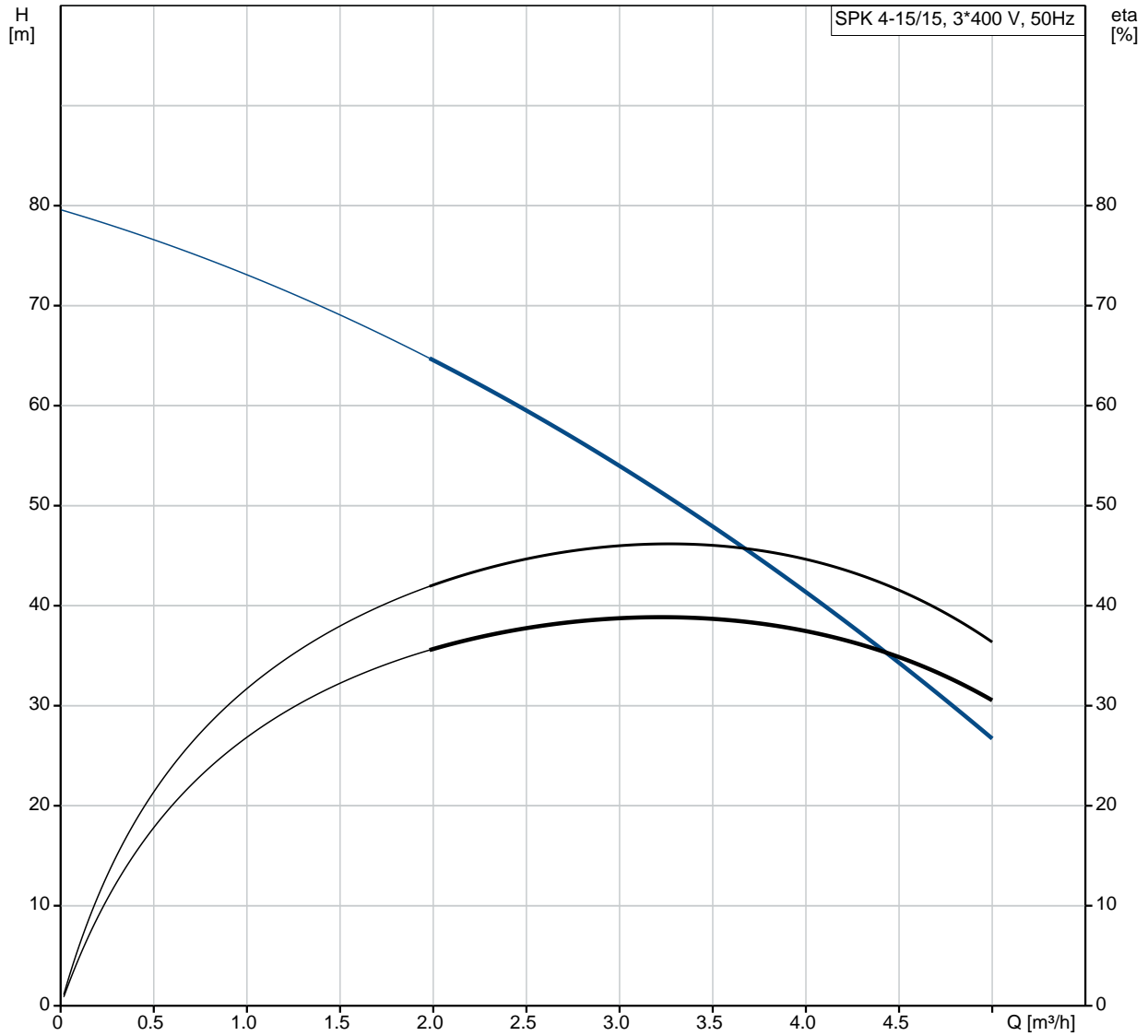

Description	Value
General information:	
Product name:	SPK 4-15/15 A-W-A-AUUV
Product No:	98776578
EAN number:	5712601223522
	5712601223522
Price:	1.066,00 GBP
Technical:	
Pump speed on which pump data are based:	2853 rpm
Rated flow:	4 m ³ /h
Rated head:	47.8 m
Stages:	15
Impellers:	15
Primary shaft seal:	AUUV
Curve tolerance:	ISO9906:2012 3B
Pump version:	A
Model:	E
Drain holes:	Open drain hole
Materials:	
Pump head:	Cast iron
	EN-GJL-200
	ASTM 25B
Impeller:	Stainless steel
	DIN W.-Nr. 1.4301
	AISI 304
Material code:	A
Installation:	
Maximum ambient temperature:	60 °C
Pipe connection:	G 3/4
Flange size for motor:	FT100
Connect code:	W
Liquid:	
Pumped liquid:	Water
Liquid temperature range:	-10 .. 90 °C
Selected liquid temperature:	20 °C
Density at selected liquid temperature:	998.2 kg/m ³
Electrical data:	
Motor type:	80C
IE Efficiency class:	IE3
Rated power - P2:	1.1 kW
Power (P2) required by pump:	1.1 kW
Mains frequency:	50 Hz
Rated voltage:	3 x 220-240D/380-415Y V
Rated current:	4.35/2.50 A
Starting current:	450-500 %
Cos phi - power factor:	0.83-0.76
Rated speed:	2840-2870 rpm
Efficiency:	IE3 82,7%
Motor efficiency at full load:	82.7 %
Motor efficiency at 3/4 load:	84.6 %
Motor efficiency at 1/2 load:	85.4 %
Number of poles:	2
Enclosure class (IEC 34-5):	55 Dust/Jetting
Insulation class (IEC 85):	F
Motor protec:	NONE
Motor No:	85U05105
Others:	

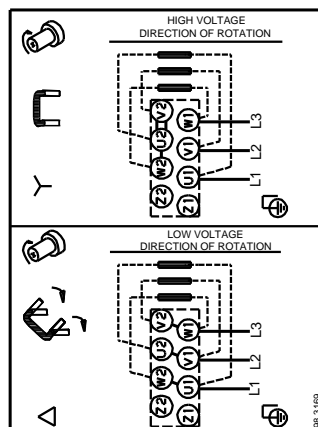
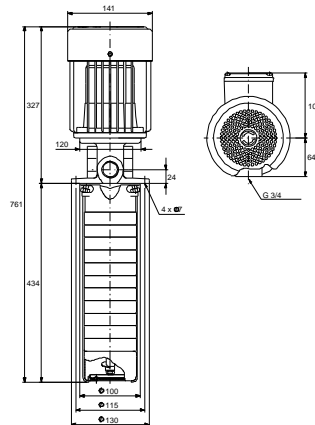
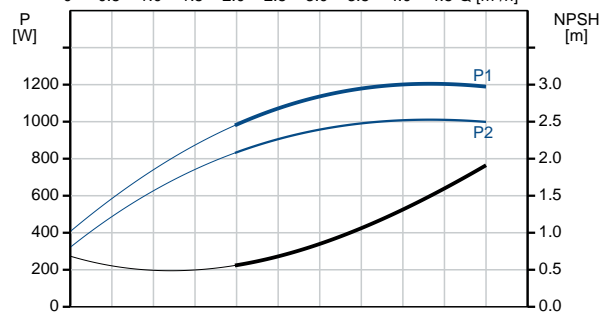
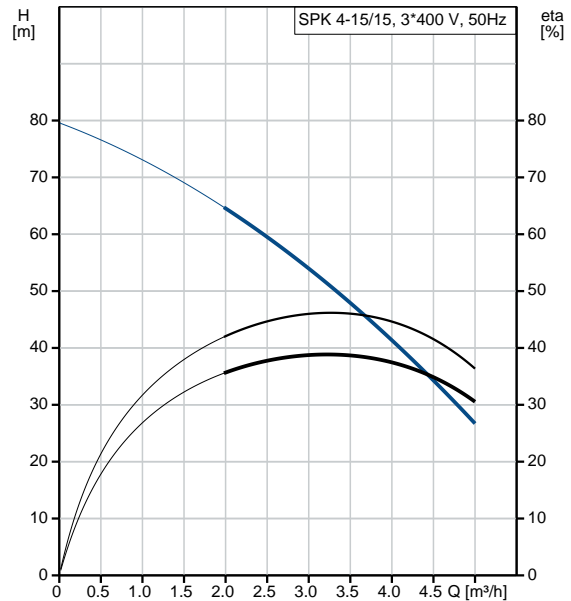



Company name:

Created by:

Phone:

Date:

15/10/2019

Description	Value
Minimum efficiency index, MEI :	N/A
Net weight:	16.3 kg
Gross weight:	17.6 kg
Country of origin:	HU
Custom tariff no.:	84137075