

**Qty. Description**

1 SPK 4-11/11 A-W-A-AUUV



Note! Product picture may differ from actual product

Product No.: [98776576](#)

Multistage, immersible, self-priming, centrifugal pump for vertical and horizontal installation in tanks etc.

The pump has the following characteristics:

- Installation length according to DIN 5440.
- Impellers, intermediate chambers and spline shaft are made of stainless steel and motor stool of GG 20.
- Mechanical shaft seal according to EN 12756.
- Power transmission via cast iron split coupling.

The motor is a 3-phase AC motor.

Immersion depth: 350 mm

**Liquid:**

Pumped liquid: Water  
 Liquid temperature range: -10 .. 90 °C  
 Selected liquid temperature: 20 °C  
 Density at selected liquid temperature: 998.2 kg/m<sup>3</sup>

**Technical:**

Pump speed on which pump data are based: 2864 rpm  
 Rated flow: 4 m<sup>3</sup>/h  
 Rated head: 34.4 m  
 Primary shaft seal: AUUV  
 Curve tolerance: ISO9906:2012 3B  
 Drain holes: Open drain hole

**Materials:**

Pump head: Cast iron  
 EN-GJL-200  
 ASTM 25B  
 Impeller: Stainless steel  
 DIN W.-Nr. 1.4301  
 AISI 304

**Installation:**

Maximum ambient temperature: 60 °C  
 Pipe connection: G 3/4  
 Flange size for motor: FT100

**Electrical data:**

Motor type: 80A  
 IE Efficiency class: IE3

Qty.	Description
	Rated power - P2: 0.75 kW
	Power (P2) required by pump: 0.75 kW
	Mains frequency: 50 Hz
	Rated voltage: 3 x 220-240D/380-415Y V
	Rated current: 3.30/1.90 A
	Starting current: 580-620 %
	Cos phi - power factor: 0.81-0.71
	Rated speed: 2840-2870 rpm
	Efficiency: IE3 80,7%
	Motor efficiency at full load: 80.7 %
	Motor efficiency at 3/4 load: 82.7 %
	Motor efficiency at 1/2 load: 81.7 %
	Number of poles: 2
	Enclosure class (IEC 34-5): 55 Dust/Jetting
	Insulation class (IEC 85): F
	Motor No: 85U05104
	<b>Others:</b>
	Minimum efficiency index, MEI : N/A
	Net weight: 13.6 kg
	Gross weight: 14.9 kg
	Country of origin: HU
	Custom tariff no.: 84137075

## 98776576 SPK 4-11/11 A-W-A-AUUV 50 Hz

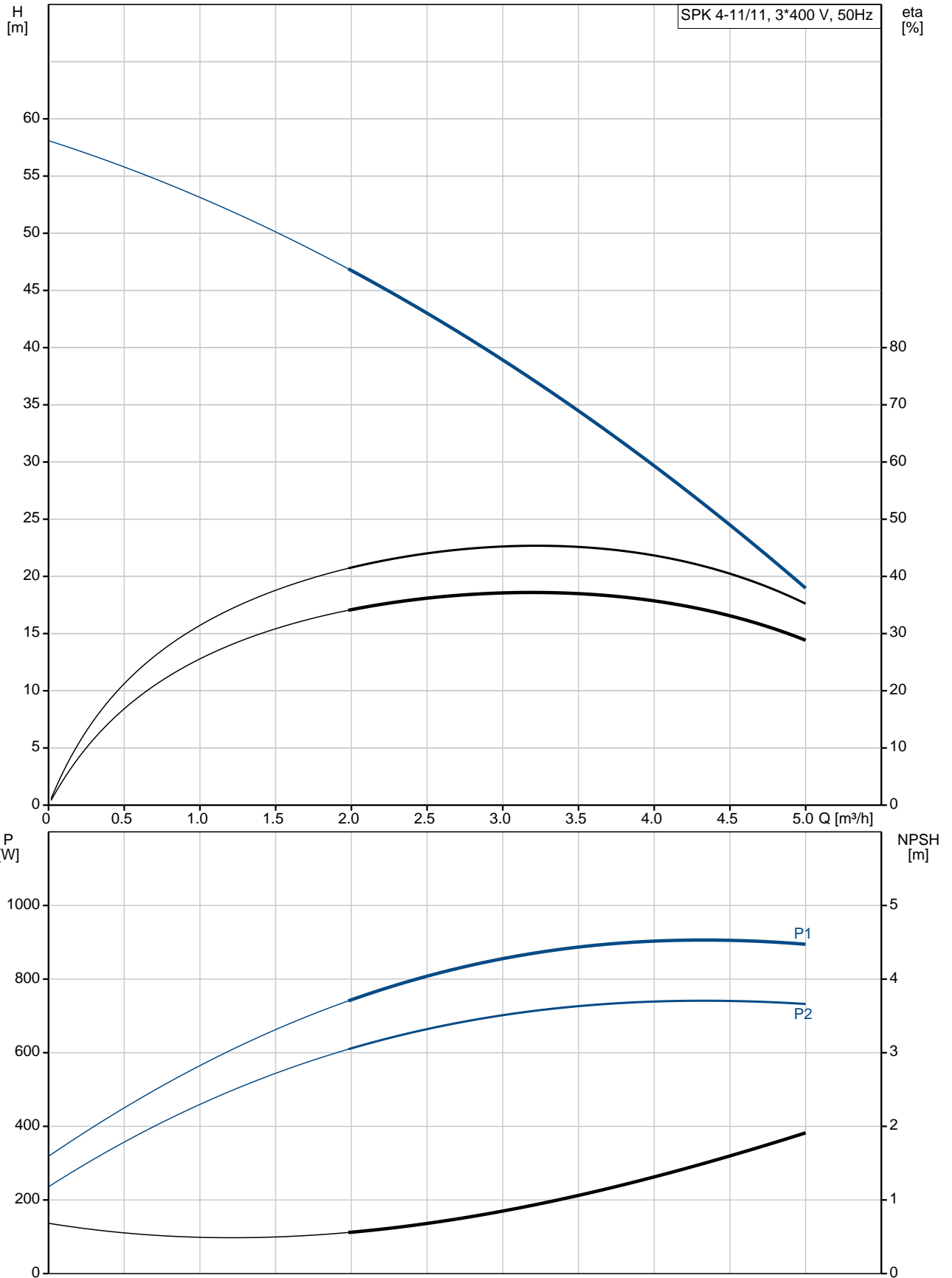

Description	Value
<b>General information:</b>	
Product name:	SPK 4-11/11 A-W-A-AUUV
Product No:	98776576
EAN number:	5712601223485
	5712601223485
Price:	871,00 GBP
<b>Technical:</b>	
Pump speed on which pump data are based:	2864 rpm
Rated flow:	4 m <sup>3</sup> /h
Rated head:	34.4 m
Stages:	11
Impellers:	11
Primary shaft seal:	AUUV
Curve tolerance:	ISO9906:2012 3B
Pump version:	A
Model:	E
Drain holes:	Open drain hole
<b>Materials:</b>	
Pump head:	Cast iron
	EN-GJL-200
	ASTM 25B
Impeller:	Stainless steel
	DIN W.-Nr. 1.4301
	AISI 304
Material code:	A
<b>Installation:</b>	
Maximum ambient temperature:	60 °C
Pipe connection:	G 3/4
Flange size for motor:	FT100
Connect code:	W
<b>Liquid:</b>	
Pumped liquid:	Water
Liquid temperature range:	-10 .. 90 °C
Selected liquid temperature:	20 °C
Density at selected liquid temperature:	998.2 kg/m <sup>3</sup>
<b>Electrical data:</b>	
Motor type:	80A
IE Efficiency class:	IE3
Rated power - P2:	0.75 kW
Power (P2) required by pump:	0.75 kW
Mains frequency:	50 Hz
Rated voltage:	3 x 220-240D/380-415Y V
Rated current:	3.30/1.90 A
Starting current:	580-620 %
Cos phi - power factor:	0.81-0.71
Rated speed:	2840-2870 rpm
Efficiency:	IE3 80,7%
Motor efficiency at full load:	80.7 %
Motor efficiency at 3/4 load:	82.7 %
Motor efficiency at 1/2 load:	81.7 %
Number of poles:	2
Enclosure class (IEC 34-5):	55 Dust/Jetting
Insulation class (IEC 85):	F
Motor protec:	NONE
Motor No:	85U05104
<b>Others:</b>	

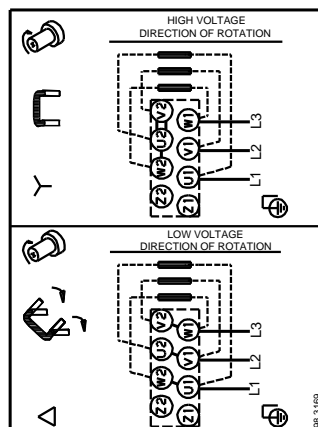
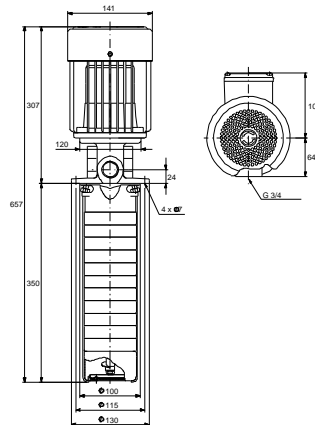
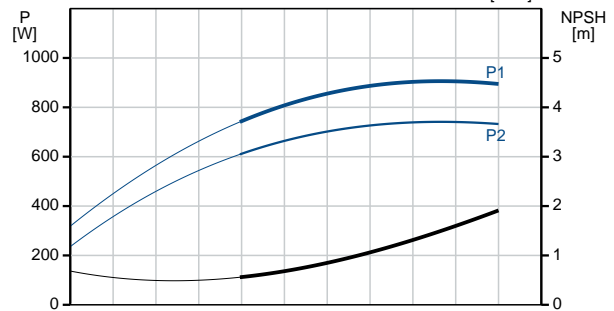
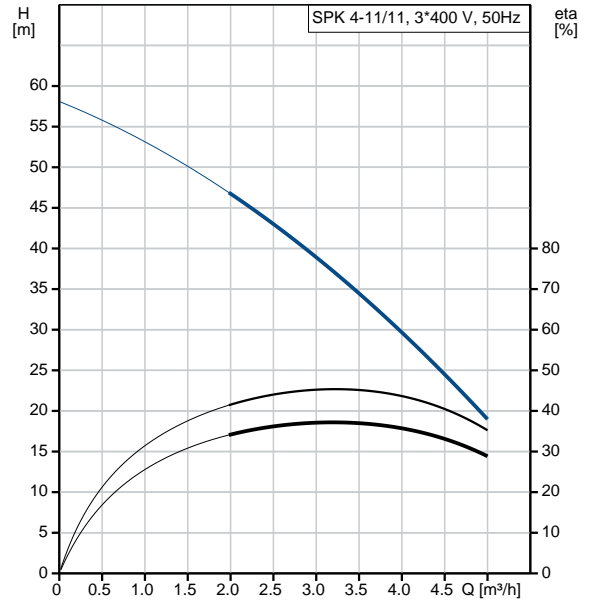



Company name:

Created by:

Phone:

Date:

15/10/2019

Description	Value
Minimum efficiency index, MEI :	N/A
Net weight:	13.6 kg
Gross weight:	14.9 kg
Country of origin:	HU
Custom tariff no.:	84137075