

Position	Qty.	Description
	1	<p>TP 50-140/4 A-F-A-BQQE</p>  <p>Product No.: 98742912</p> <p>Single-stage, close-coupled, volute pump with in-line suction and discharge ports of identical diameter. The pump is of the top-pull-out design, i.e. the power head (motor, pump head and impeller) can be removed for maintenance or service while the pump housing remains in the pipework.</p> <p>The pump is fitted with an unbalanced rubber bellows seal. The shaft seal is according to EN 12756. Pipework connection is via PN 16 DIN flanges (EN 1092-2 and ISO 7005-2).</p> <p>The pump is fitted with a fan-cooled asynchronous motor.</p> <p>Liquid: Pumped liquid: Water Liquid temperature range: -25 .. 120 °C Liquid temperature during operation: 20 °C Density: 998.2 kg/m³</p> <p>Technical: Speed for pump data: 1450 rpm Rated flow: 25.3 m³/h Rated head: 12.16 m Actual impeller diameter: 215 mm Primary shaft seal: BQQE Curve tolerance: ISO9906:2012 3B</p> <p>Materials: Pump housing: Cast iron EN-JL1040 ASTM A48-40 B Impeller: Cast iron EN-JL1030 ASTM A48-30 B</p> <p>Installation: Range of ambient temperature: -30 .. 60 °C Maximum operating pressure: 16 bar Flange standard: DIN Pipe connection: DN 50 Pump inlet: DN 50 Pump outlet: DN 50 Pressure stage: PN 16 Port-to-port length: 440 mm Flange size for motor: FF165</p> <p>Electrical data: Motor type: 90LC IE Efficiency class: IE3 Rated power - P2: 1.5 kW Power (P2) required by pump: 1.5 kW Mains frequency: 50 Hz</p>

Position	Qty.	Description
		<p>Rated voltage: 3 x 220-240D/380-415Y V Rated current: 6,15-6,30/3,55-3,65 A Starting current: 730-790 % Cos phi - power factor: 0,75-0,68 Rated speed: 1450-1460 rpm Efficiency: IE3 85,3% Motor efficiency at full load: 85.3 % Motor efficiency at 3/4 load: 85.8 % Motor efficiency at 1/2 load: 84.2 % Number of poles: 4 Enclosure class (IEC 34-5): 55 Dust/Jetting Insulation class (IEC 85): F</p> <p>Others:</p> <p>Label: Grundfos Blueflux Minimum efficiency index, MEI : 0.7 ErP status: EuP Standalone/Prod. Net weight: 70 kg Gross weight: 84 kg Shipping volume: 0.39 m³</p>

98742912 TP 50-140/4 50 Hz

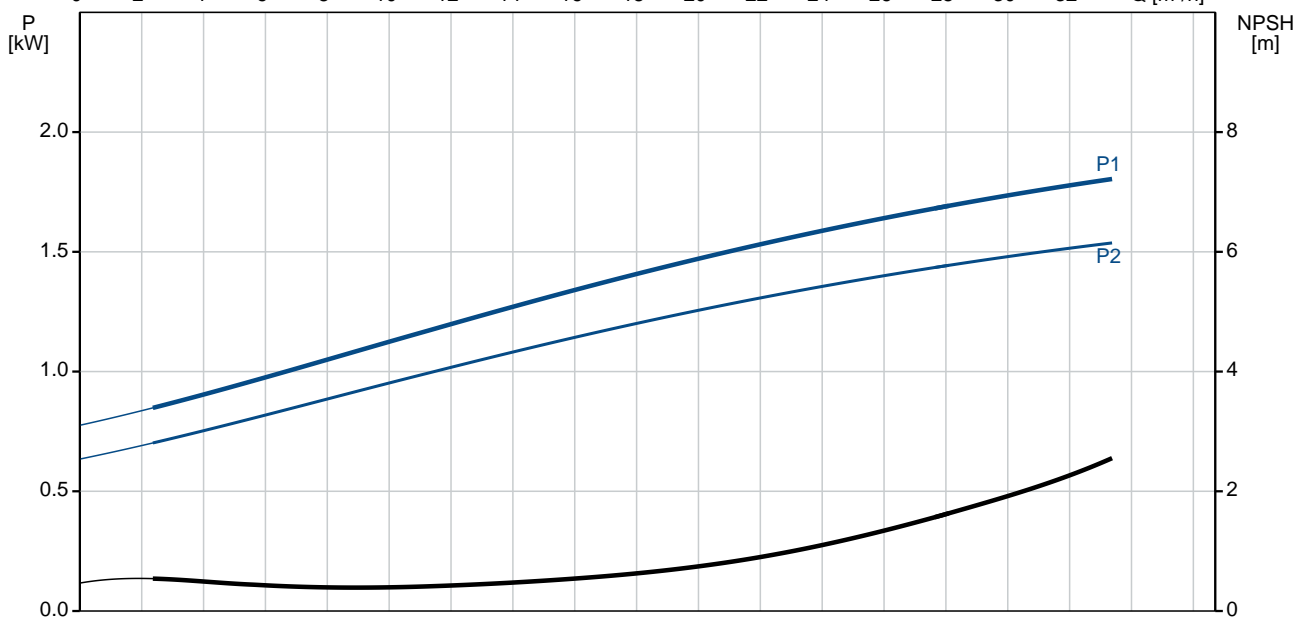
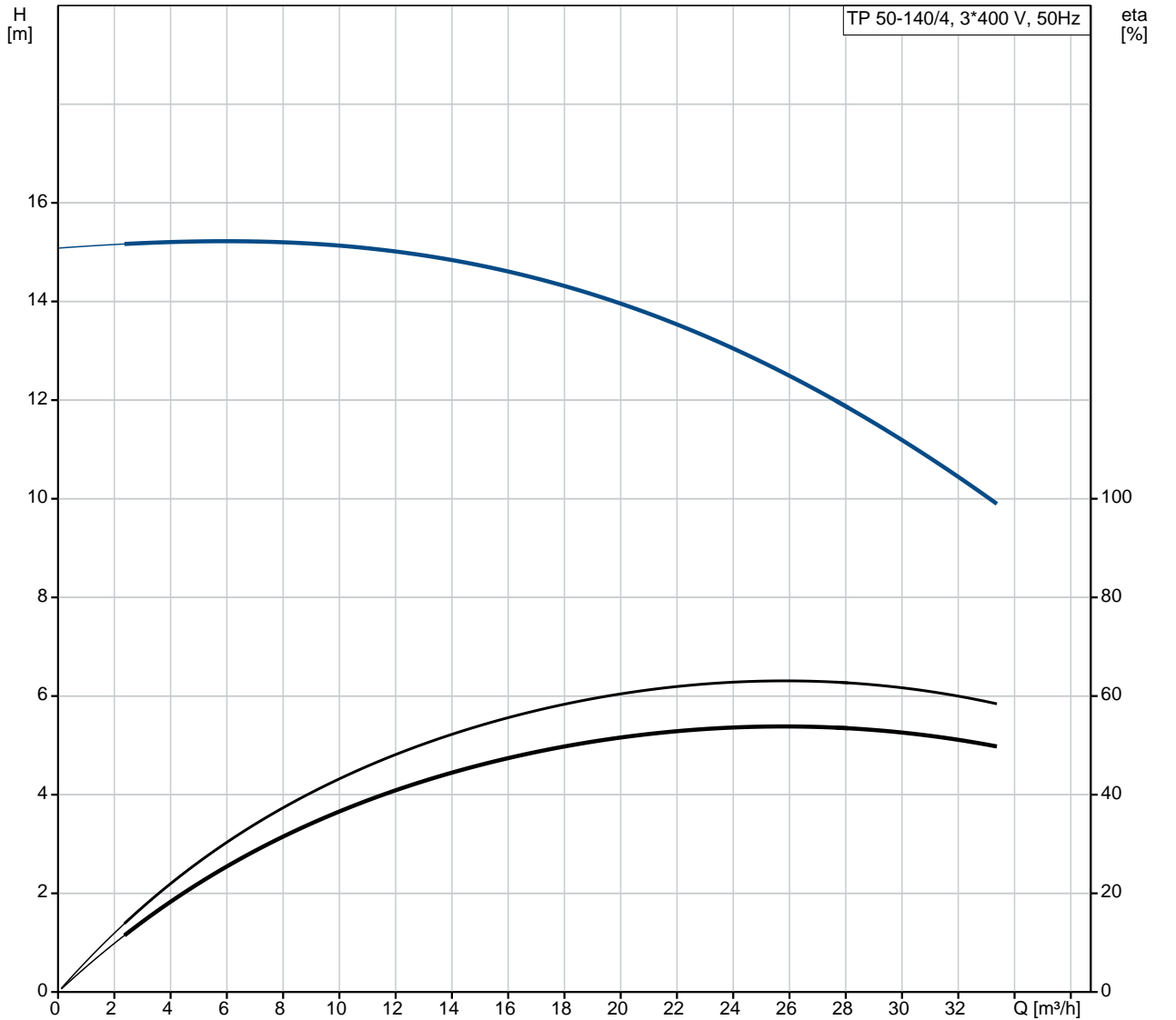

Description	Value
General information:	
Product name:	TP 50-140/4 A-F-A-BQQE
Product No:	98742912
EAN number:	5712600816237
Technical:	
Speed for pump data:	1450 rpm
Rated flow:	25.3 m ³ /h
Rated head:	12.16 m
Head max:	140 dm
Actual impeller diameter:	215 mm
Primary shaft seal:	BQQE
Curve tolerance:	ISO9906:2012 3B
Pump version:	A
Model:	A
Materials:	
Pump housing:	Cast iron EN-JL1040 ASTM A48-40 B
Impeller:	Cast iron EN-JL1030 ASTM A48-30 B
Material code:	A
Installation:	
Range of ambient temperature:	-30 .. 60 °C
Maximum operating pressure:	16 bar
Flange standard:	DIN
Connect code:	F
Pipe connection:	DN 50
Pump inlet:	DN 50
Pump outlet:	DN 50
Pressure stage:	PN 16
Port-to-port length:	440 mm
Flange size for motor:	FF165
Liquid:	
Pumped liquid:	Water
Liquid temperature range:	-25 .. 120 °C
Liquid temperature during operation:	20 °C
Density:	998.2 kg/m ³
Electrical data:	
Motor type:	90LC
IE Efficiency class:	IE3
Rated power - P2:	1.5 kW
Power (P2) required by pump:	1.5 kW
Mains frequency:	50 Hz
Rated voltage:	3 x 220-240D/380-415Y V
Rated current:	6,15-6,30/3,55-3,65 A
Starting current:	730-790 %
Cos phi - power factor:	0,75-0,68
Rated speed:	1450-1460 rpm
Efficiency:	IE3 85,3%
Motor efficiency at full load:	85.3 %
Motor efficiency at 3/4 load:	85.8 %
Motor efficiency at 1/2 load:	84.2 %
Number of poles:	4

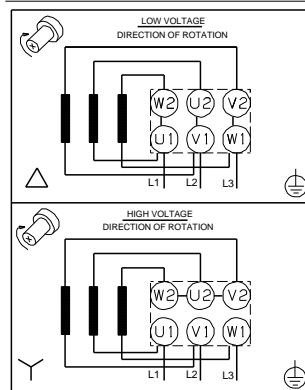
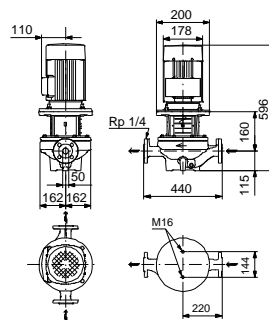
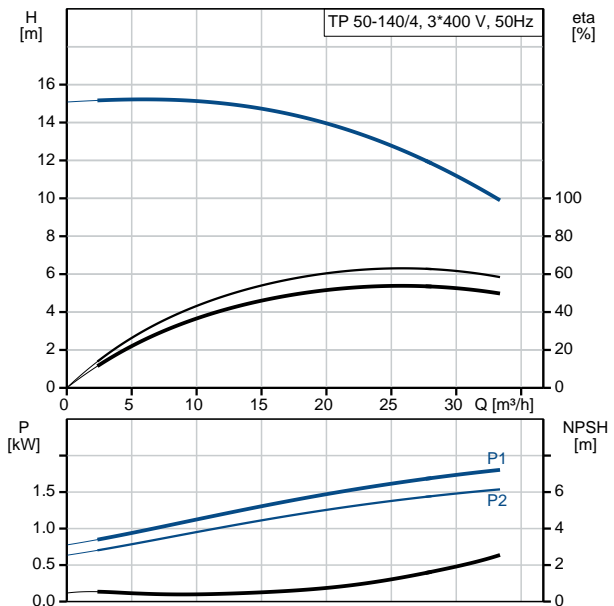



Company name:

Created by:

Phone:

Date:

31/08/2017

Description	Value
Enclosure class (IEC 34-5):	55 Dust/Jetting
Insulation class (IEC 85):	F
Motor protec:	NONE
Motor No:	87220319
Others:	
Label:	Grundfos Blueflux
Minimum efficiency index, MEI :	0.7
ErP status:	EuP Standalone/Prod.
Net weight:	70 kg
Gross weight:	84 kg
Shipping volume:	0.39 m ³

98742912 TP 50-140/4 50 Hz

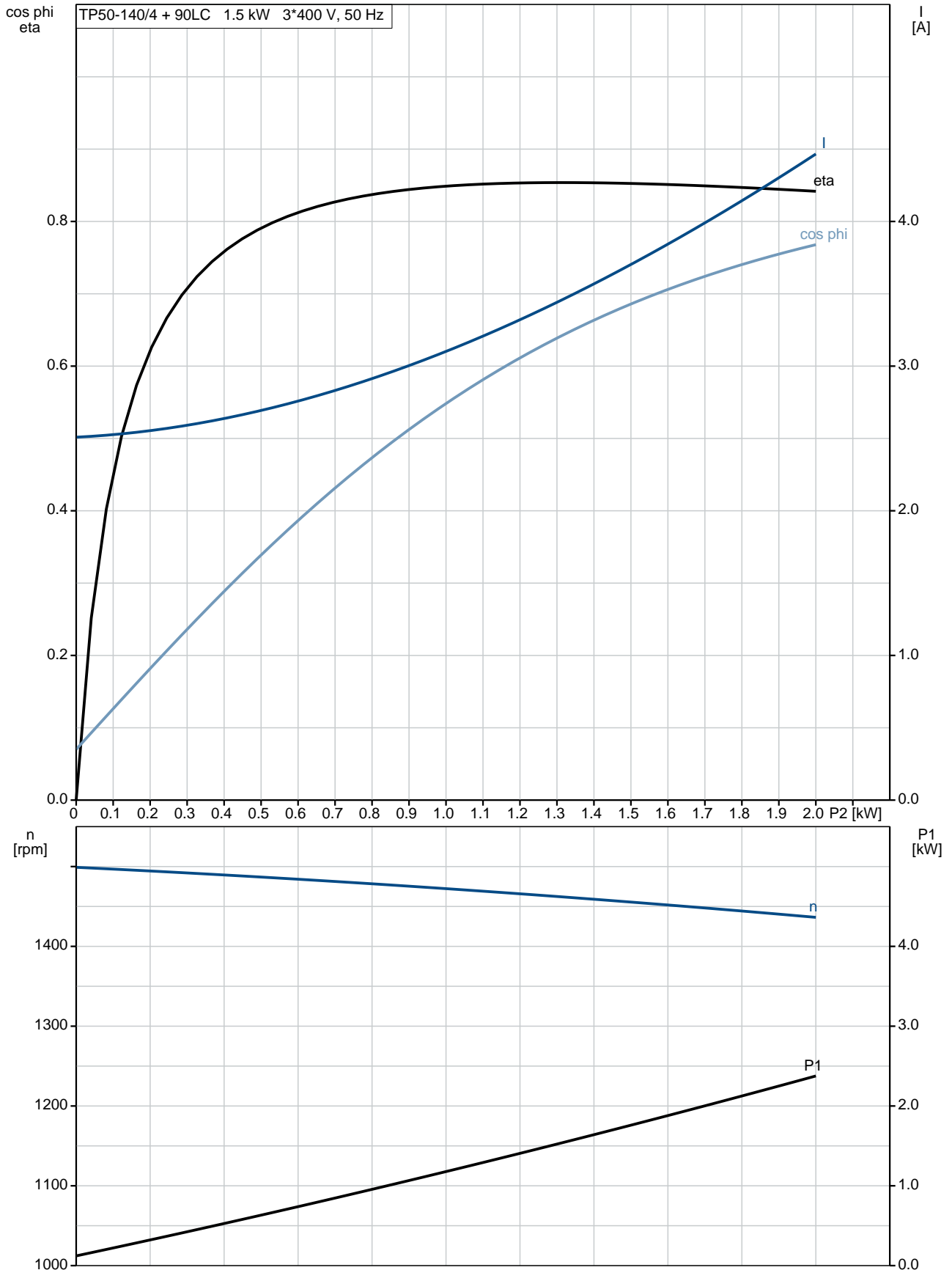

98742912 TP 50-140/4 50 Hz

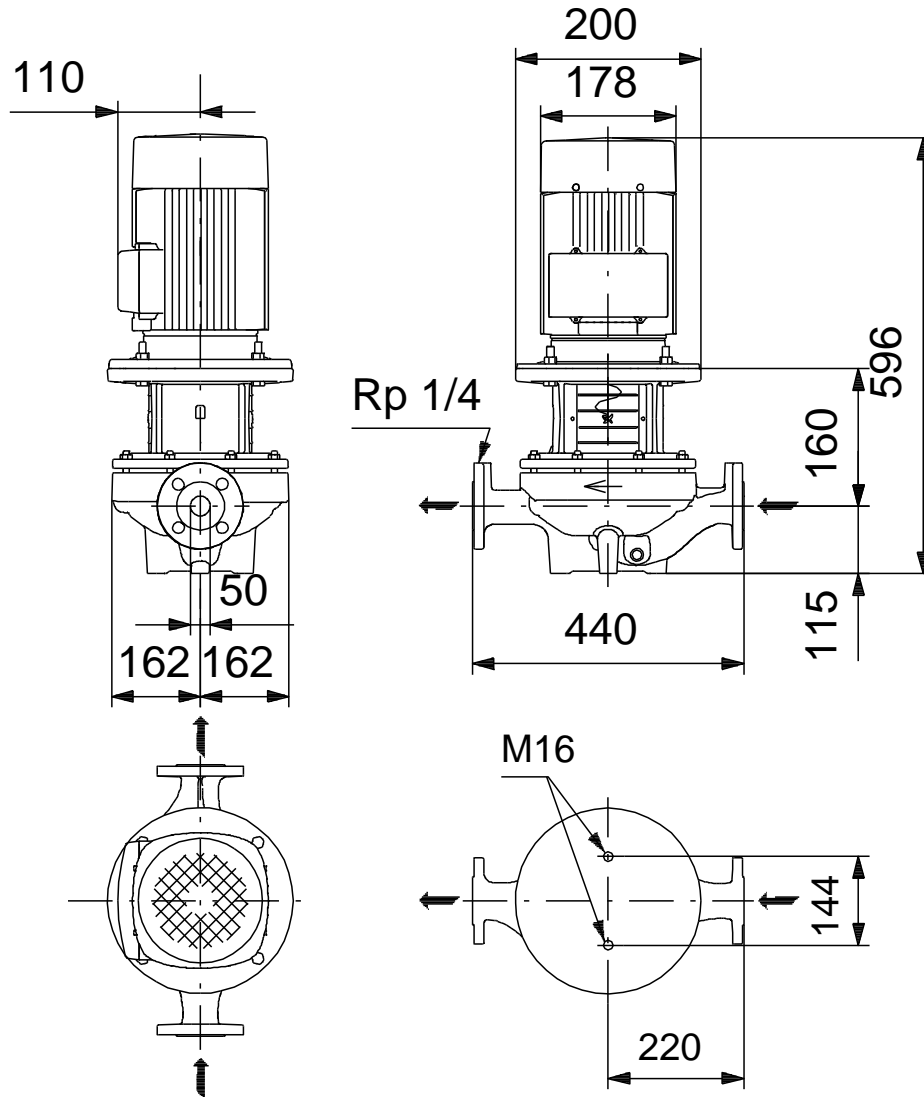

Note! All units are in [mm] unless others are stated.
Disclaimer: This simplified dimensional drawing does not show all details.

98742912 TP 50-140/4 50 Hz

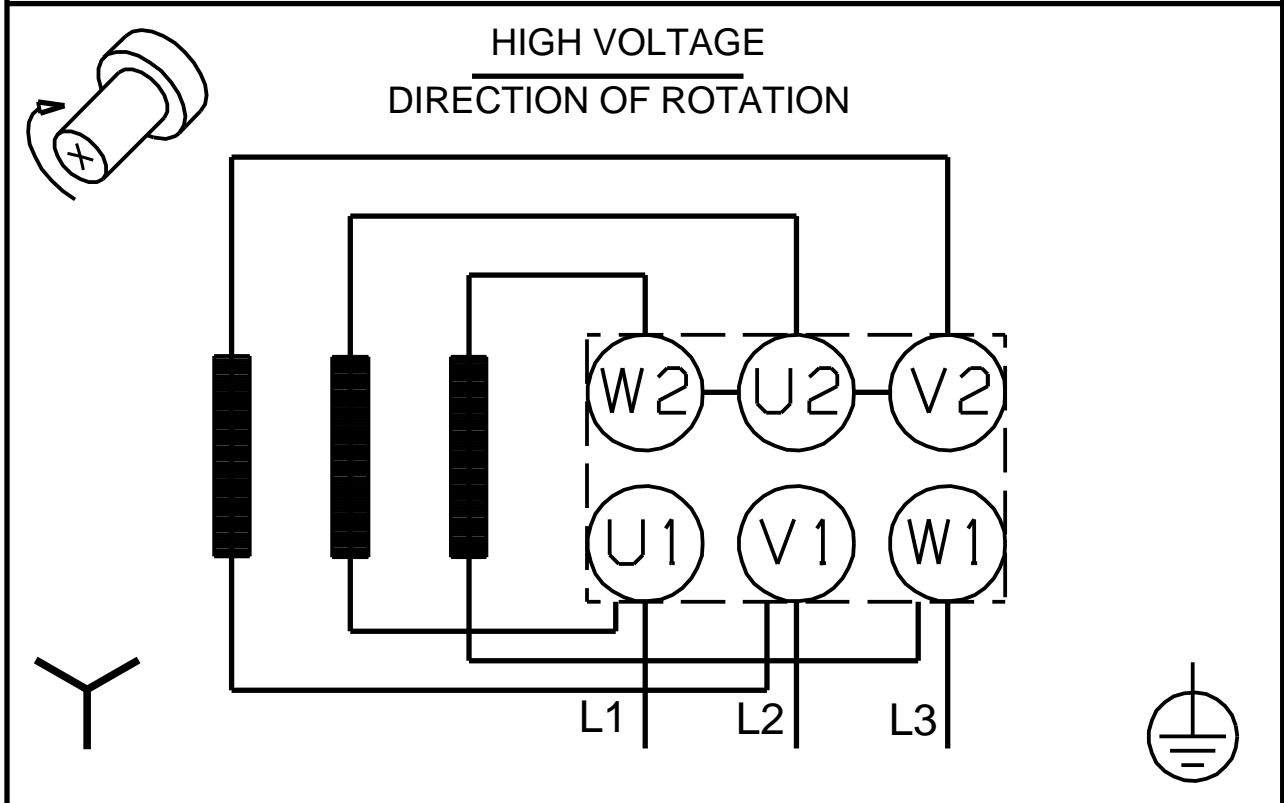
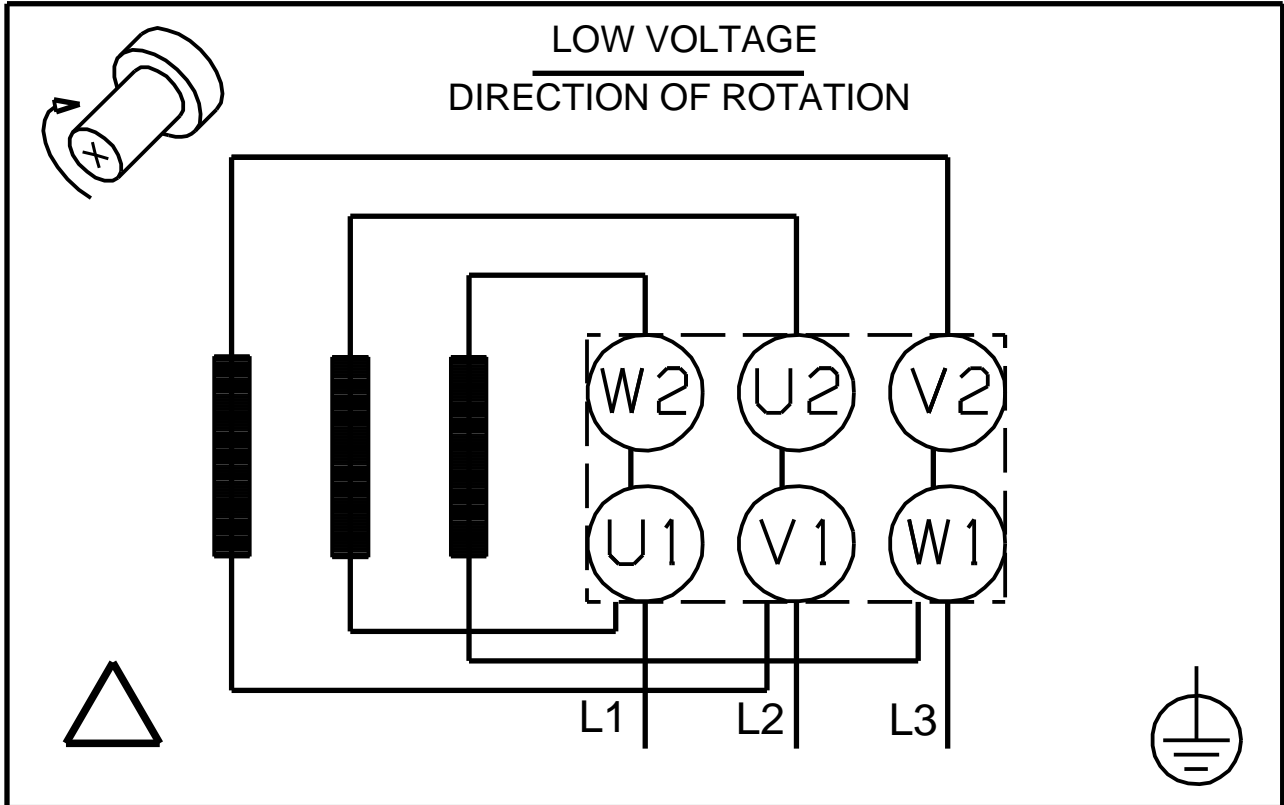

Note! All units are in [mm] unless others are stated.