

Qty.	Description
1	<p data-bbox="199 338 518 369">NB 32-250/219 AF2ABQQE</p> <div data-bbox="290 450 501 607" style="text-align: center;">  </div> <p data-bbox="199 660 470 692">Product No.: 98665396</p> <p data-bbox="199 719 1460 772">Non-self-priming, single-stage, centrifugal volute pump designed according to ISO 5199 with dimensions and rated performance according to EN 733 (10 bar).</p> <p data-bbox="199 806 1452 884">Flanges are PN 16 with dimensions according to EN 1092-2. The pump has an axial suction port, radial discharge port, horizontal shaft and a back pull-out design enabling removal of the motor, motor stool, cover and impeller without disturbing the pump housing or pipework.</p> <p data-bbox="199 896 941 927">The unbalanced rubber bellows seal is according to DIN EN 12756.</p> <p data-bbox="199 927 909 958">The pump is close-coupled to a fan-cooled asynchronous motor.</p> <p data-bbox="199 981 311 1012">Controls:</p> <p data-bbox="199 1012 638 1043">Frequency converter: NONE</p> <p data-bbox="199 1070 287 1102">Liquid:</p> <p data-bbox="199 1102 638 1133">Pumped liquid: Water</p> <p data-bbox="199 1133 710 1164">Liquid temperature range: -25 .. 120 °C</p> <p data-bbox="199 1164 686 1196">Liquid temperature during operation: 20 °C</p> <p data-bbox="199 1196 702 1227">Density: 998.2 kg/m³</p> <p data-bbox="199 1249 327 1281">Technical:</p> <p data-bbox="199 1281 678 1312">Rated flow: 21.6 m³/h</p> <p data-bbox="199 1312 662 1344">Rated head: 50.45 m</p> <p data-bbox="199 1344 662 1375">Actual impeller diameter: 219 mm</p> <p data-bbox="199 1375 662 1406">Nominal impeller diameter: 250 mm</p> <p data-bbox="199 1406 638 1438">Shaft seal arrangement: Single</p> <p data-bbox="199 1438 638 1469">Code for shaft seal: BQQE</p> <p data-bbox="199 1469 766 1500">Curve tolerance: ISO9906:2012 3B</p> <p data-bbox="199 1523 319 1554">Materials:</p> <p data-bbox="199 1554 734 1635">Pump housing: Cast iron EN-GJL-250 ASTM class 35</p> <p data-bbox="199 1635 638 1666">Wear ring: Brass</p> <p data-bbox="199 1666 734 1747">Impeller: Cast iron EN-GJL-200 ASTM class 30</p> <p data-bbox="199 1747 734 1836">Shaft: Stainless steel EN 1.4301 AISI 304</p> <p data-bbox="199 1877 343 1908">Installation:</p> <p data-bbox="199 1908 630 1939">Maximum ambient temperature: 60 °C</p> <p data-bbox="199 1939 638 1971">Maximum operating pressure: 16 bar</p> <p data-bbox="199 1971 686 2002">Pipe connection standard: EN 1092-2</p> <p data-bbox="199 2002 638 2033">Size of inlet connection: DN 50</p> <p data-bbox="199 2033 638 2065">Size of outlet connection: DN 32</p> <p data-bbox="199 2065 686 2096">Pressure rating for pipe connection: PN 16</p> <p data-bbox="199 2096 582 2128">Pump housing with feet: Y</p>

Qty.	Description
	Support block: N
	Electrical data:
	IE Efficiency class: IE3
	P2: 7.5 kW
	Mains frequency: 50 Hz
	Rated voltage: 3 x 380-415D/660-690Y V
	Rated current: 14,4-14,0/8,30-8,10 A
	Starting current: 780-910 %
	Cos phi - power factor: 0.88-0.86
	Rated speed: 2910-2920 rpm
	Efficiency: IE3 90,1% - IE3 90,4%
	Motor efficiency at full load: 90.1-90.4 %
	Motor efficiency at 3/4 load: 90.8 %
	Motor efficiency at 1/2 load: 90.8 %
	Number of poles: 2
	Enclosure class (IEC 34-5): 55 Dust/Jetting
	Insulation class (IEC 85): F
	Others:
	Minimum efficiency index, MEI $\hat{\alpha}\%$: 0.70
	Net weight: 101 kg
	Gross weight: 122 kg
	Shipping volume: 0.509 m ³
	Country of origin: HU
	Custom tariff no.: 84137051

98665396 NB 32-250/219 AF2ABQQE 50 Hz

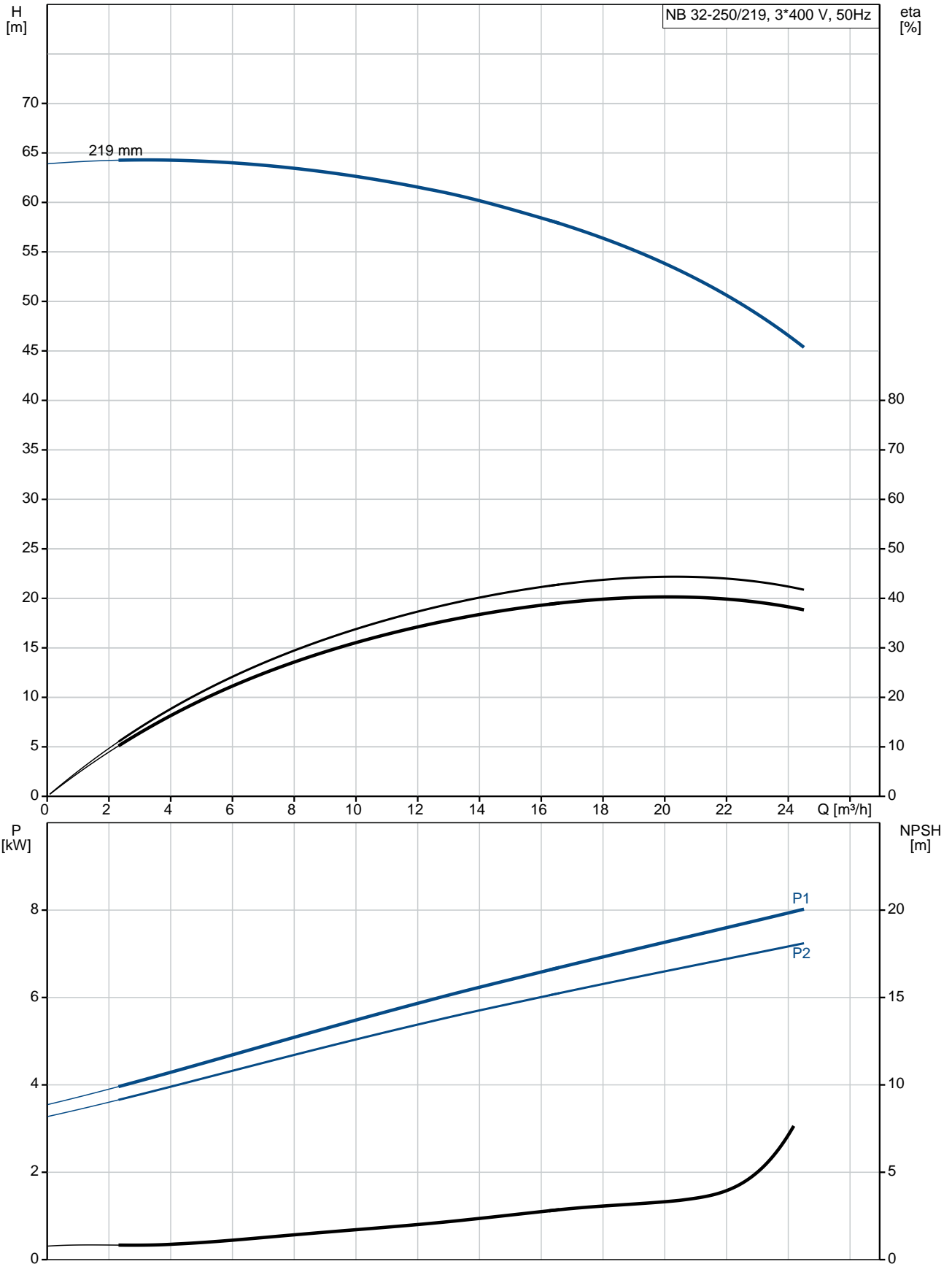

Description	Value
General information:	
Product name:	NB 32-250/219 AF2ABQQE
Product No:	98665396
EAN number:	5711499202213
Price:	2.563,00 GBP
Technical:	
Rated flow:	21.6 m ³ /h
Rated head:	50.45 m
Actual impeller diameter:	219 mm
Nominal impeller diameter:	250 mm
Shaft seal arrangement:	Single
Shaft diameter:	24 mm
Code for shaft seal:	BQQE
Curve tolerance:	ISO9906:2012 3B
Pump version:	A
Materials:	
Pump housing:	Cast iron EN-GJL-250 ASTM class 35
Wear ring:	Brass
Impeller:	Cast iron EN-GJL-200 ASTM class 30
Shaft:	Stainless steel EN 1.4301 AISI 304
Material code:	A
Installation:	
Maximum ambient temperature:	60 °C
Maximum operating pressure:	16 bar
Pipe connection standard:	EN 1092-2
Size of inlet connection:	DN 50
Size of outlet connection:	DN 32
Pressure rating for pipe connection:	PN 16
Pump housing with feet:	Y
Support block:	N
Connect code:	F2
Liquid:	
Pumped liquid:	Water
Liquid temperature range:	-25 .. 120 °C
Liquid temperature during operation:	20 °C
Density:	998.2 kg/m ³
Electrical data:	
IE Efficiency class:	IE3
P2:	7.5 kW
Mains frequency:	50 Hz
Rated voltage:	3 x 380-415D/660-690Y V
Rated current:	14,4-14,0/8,30-8,10 A
Starting current:	780-910 %
Cos phi - power factor:	0.88-0.86
Rated speed:	2910-2920 rpm
Efficiency:	IE3 90,1% - IE3 90,4%
Motor efficiency at full load:	90.1-90.4 %
Motor efficiency at 3/4 load:	90.8 %
Motor efficiency at 1/2 load:	90.8 %
Number of poles:	2
Enclosure class (IEC 34-5):	55 Dust/Jetting
Insulation class (IEC 85):	F

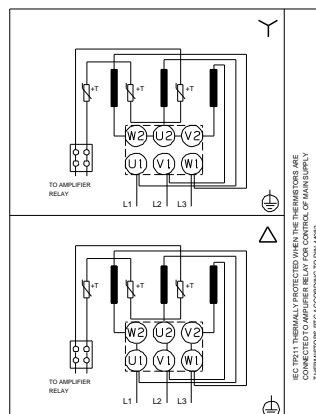
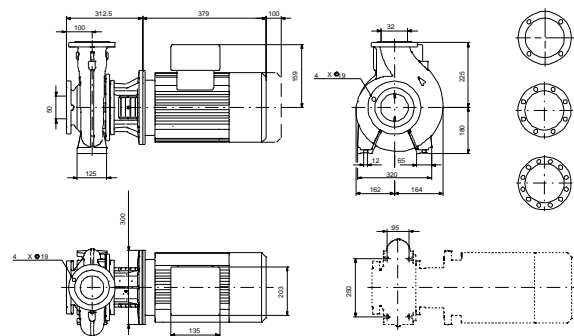
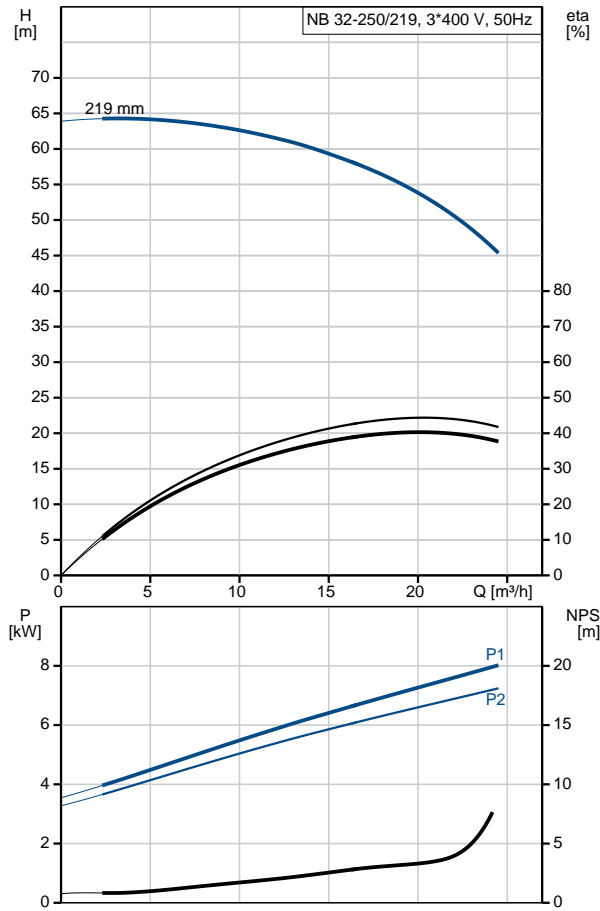



Company name:

Created by:

Phone:

Date:

21/03/2019

Description	Value
Motor protec:	PTC
Motor No:	87370232
Mount. design. acc. IEC 34-7:	IM V1/B5
Controls:	
Frequency converter:	NONE
Others:	
Minimum efficiency index, MEI $\eta_{\%}$:	0.70
Net weight:	101 kg
Gross weight:	122 kg
Shipping volume:	0.509 m ³
Country of origin:	HU
Custom tariff no.:	84137051

98665396 NB 32-250/219 AF2ABQQE 50 Hz

