

Qty. Description

1 NB 50-125/135 ASF2ABQQE



Note! Product picture may differ from actual product

Product No.: [98627328](#)

Non-self-priming, single-stage, centrifugal volute pump designed according to ISO 5199 with dimensions and rated performance according to EN 733 (10 bar).

Flanges are PN 16 with dimensions according to EN 1092-2. The pump has an axial suction port, radial discharge port, horizontal shaft and a back pull-out design enabling removal of the motor, motor stool, cover and impeller without disturbing the pump housing or pipework.

The unbalanced rubber bellows seal is according to DIN EN 12756.

The pump is close-coupled to a fan-cooled asynchronous motor.

Controls:

Frequency converter: NONE

Liquid:

Pumped liquid: Water
 Liquid temperature range: -25 .. 120 °C
 Liquid temperature during operation: 20 °C
 Density: 998.2 kg/m³

Technical:

Rated flow: 75.7 m³/h
 Rated head: 19.06 m
 Actual impeller diameter: 135 mm
 Nominal impeller diameter: 125 mm
 Shaft seal arrangement: Single
 Code for shaft seal: BQQE
 Curve tolerance: ISO9906:2012 3B

Materials:

Pump housing: Cast iron
 EN-GJL-250
 ASTM class 35
 Wear ring: Brass
 Impeller: Cast iron
 EN-GJL-200
 ASTM class 30
 Shaft: Stainless steel
 EN 1.4301
 AISI 304

Installation:

Maximum ambient temperature: 60 °C
 Maximum operating pressure: 16 bar
 Pipe connection standard: EN 1092-2
 Size of inlet connection: DN 65
 Size of outlet connection: DN 50
 Pressure rating for pipe connection: PN 16
 Pump housing with feet: Y

Qty.	Description
	<p>Support block: Y</p> <p>Electrical data:</p> <p>IE Efficiency class: IE3</p> <p>P2: 5.5 kW</p> <p>Mains frequency: 50 Hz</p> <p>Rated voltage: 3 x 380-415D V</p> <p>Rated current: 11 A</p> <p>Starting current: 1080-1180 %</p> <p>Cos phi - power factor: 0.87-0.82</p> <p>Rated speed: 2920-2940 rpm</p> <p>Efficiency: IE3 89,2%</p> <p>Motor efficiency at full load: 89.2 %</p> <p>Motor efficiency at 3/4 load: 90.0 %</p> <p>Motor efficiency at 1/2 load: 89.6 %</p> <p>Number of poles: 2</p> <p>Enclosure class (IEC 34-5): 55 Dust/Jetting</p> <p>Insulation class (IEC 85): F</p> <p>Others:</p> <p>Minimum efficiency index, MEI $\hat{\alpha}\%$: 0.70</p> <p>Net weight: 81 kg</p> <p>Gross weight: 103 kg</p> <p>Shipping volume: 0.509 m³</p> <p>Country of origin: HU</p> <p>Custom tariff no.: 84137051</p>

98627328 NB 50-125/135 ASF2ABQQE 50 Hz

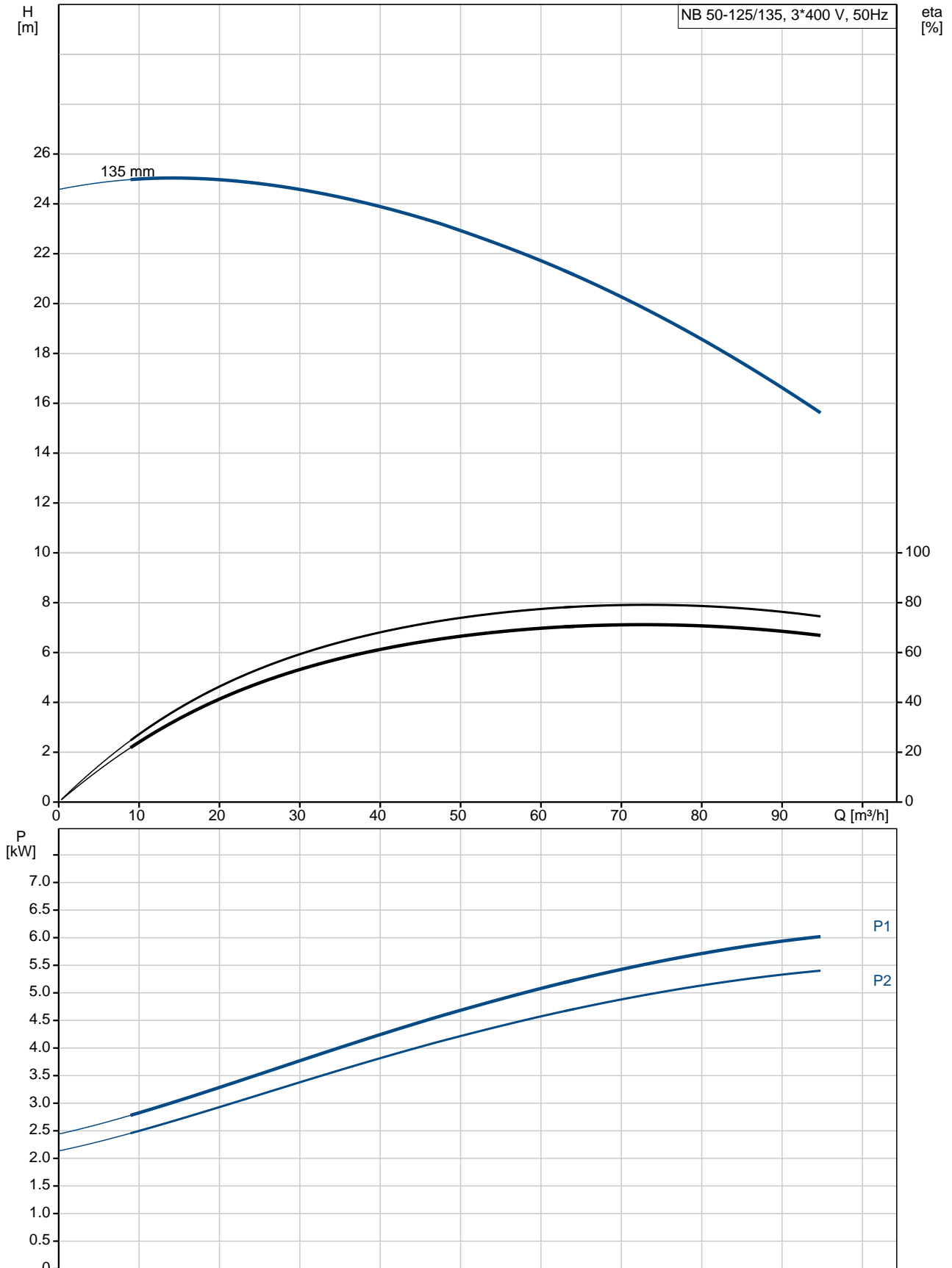

Description	Value
-------------	-------

General information:

Product name: NB 50-125/135 ASF2ABQQE

Product No: [98627328](#)

EAN number: 5711498490833

Price: 2.237,00 GBP

Technical:

Rated flow: 75.7 m³/h

Rated head: 19.06 m

Actual impeller diameter: 135 mm

Nominal impeller diameter: 125 mm

Shaft seal arrangement: Single

Shaft diameter: 24 mm

Code for shaft seal: BQQE

Curve tolerance: ISO9906:2012 3B

Pump version: AS

Materials:

Pump housing: Cast iron

EN-GJL-250

ASTM class 35

Wear ring: Brass

Impeller: Cast iron

EN-GJL-200

ASTM class 30

Shaft: Stainless steel

EN 1.4301

AISI 304

Material code: A

Installation:

Maximum ambient temperature: 60 °C

Maximum operating pressure: 16 bar

Pipe connection standard: EN 1092-2

Size of inlet connection: DN 65

Size of outlet connection: DN 50

Pressure rating for pipe connection: PN 16

Pump housing with feet: Y

Support block: Y

Connect code: F2

Liquid:

Pumped liquid: Water

Liquid temperature range: -25 .. 120 °C

Liquid temperature during operation: 20 °C

Density: 998.2 kg/m³

Electrical data:

IE Efficiency class: IE3

P2: 5.5 kW

Mains frequency: 50 Hz

Rated voltage: 3 x 380-415D V

Rated current: 11 A

Starting current: 1080-1180 %

Cos phi - power factor: 0.87-0.82

Rated speed: 2920-2940 rpm

Efficiency: IE3 89,2%

Motor efficiency at full load: 89.2 %

Motor efficiency at 3/4 load: 90.0 %

Motor efficiency at 1/2 load: 89.6 %

Number of poles: 2

Enclosure class (IEC 34-5): 55 Dust/Jetting

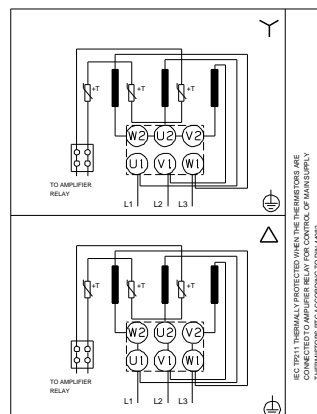
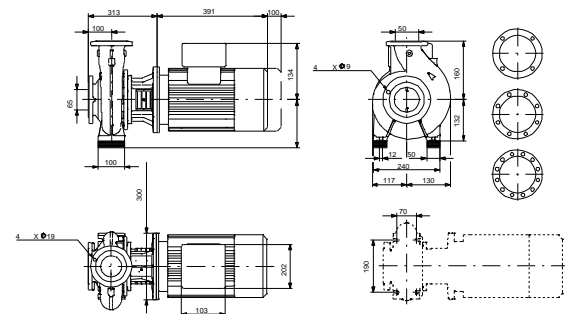
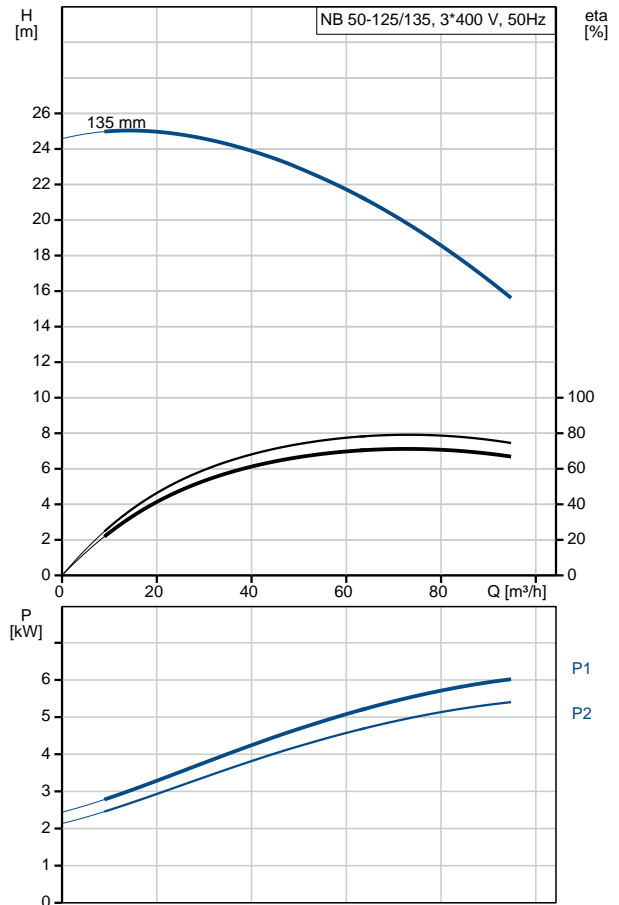



Company name:

Created by:

Phone:

Date:

21/03/2019

Description	Value
Insulation class (IEC 85):	F
Motor protec:	PTC
Motor No:	87322229
Mount. design. acc. IEC 34-7:	IM V1/B5
Controls:	
Frequency converter:	NONE
Others:	
Minimum efficiency index, MEI $\eta_{\%}$:	0.70
Net weight:	81 kg
Gross weight:	103 kg
Shipping volume:	0.509 m ³
Country of origin:	HU
Custom tariff no.:	84137051

98627328 NB 50-125/135 ASF2ABQQE 50 Hz

