

Qty. Description

1 MTR 20-2/2 A-W-A-HUUV



Product No.: [98513662](#)

Multistage, immersible, self-priming, centrifugal pump for vertical installation in tanks etc. The pump head and base are in cast iron – all other wetted parts are in stainless steel.

The pump has the following characteristics:

- Installation length according to DIN 5440.
- Impellers, intermediate chambers and spline shaft are made of Stainless steel.
- Mechanical shaft seal according to EN 12756.
- Power transmission via cast-iron split coupling.

A cartridge shaft seal ensures high reliability, safe handling, and easy access and service. The pump is fitted with a 3-phase, fan-cooled asynchronous motor.

Controls:

Frequency converter: NONE

Liquid:

Pumped liquid: Water
 Liquid temperature range: -10 .. 90 °C
 Selected liquid temperature: 20 °C
 Density at selected liquid temperature: 998.2 kg/m³

Technical:

Pump speed on which pump data are based: 2899 rpm
 Rated flow: 21 m³/h
 Rated head: 22.3 m
 Chambers: 2
 Drainage back to tank: N
 Pump orientation: Vertical
 Code for shaft seal: HUUV
 Curve tolerance: ISO9906:2012 3B

Materials:

Pump head: Cast iron
 EN 1561 EN-GJL-200
 ASTM A48-25B
 Impeller: Stainless steel
 EN 1.4301
 AISI 304

Installation:

Maximum ambient temperature: 60 °C
 Maximum operating pressure: 25 bar
 Max pressure at stated temp: 25 bar / 90 °C
 Type of connection: G
 Size of outlet connection: 2 inch

Qty.	Description
	Immersion depth: 178 mm Flange size for motor: FT115 Electrical data: Motor standard: IEC Motor type: 90LC IE Efficiency class: IE3 Rated power - P2: 2.2 kW Mains frequency: 50 Hz Rated voltage: 3 x 380-415D V Rated current: 4.45 A Starting current: 850-950 % Cos phi - power factor: 0.89-0.87 Rated speed: 2890-2910 rpm Efficiency: IE3 85,9% Motor efficiency at full load: 85.9 % Motor efficiency at 3/4 load: 86.8 % Motor efficiency at 1/2 load: 86.0 % Number of poles: 2 Enclosure class (IEC 34-5): 55 Dust/Jetting Insulation class (IEC 85): F Motor No: 85U15908 Others: Terminal box position: 6 Minimum efficiency index, MEI : 0.70 Net weight: 37 kg Gross weight: 40.5 kg Shipping volume: 0.08 m ³ Country of origin: HU Custom tariff no.: 84137075

98513662 MTR 20-2/2 A-W-A-HUUV 50 Hz

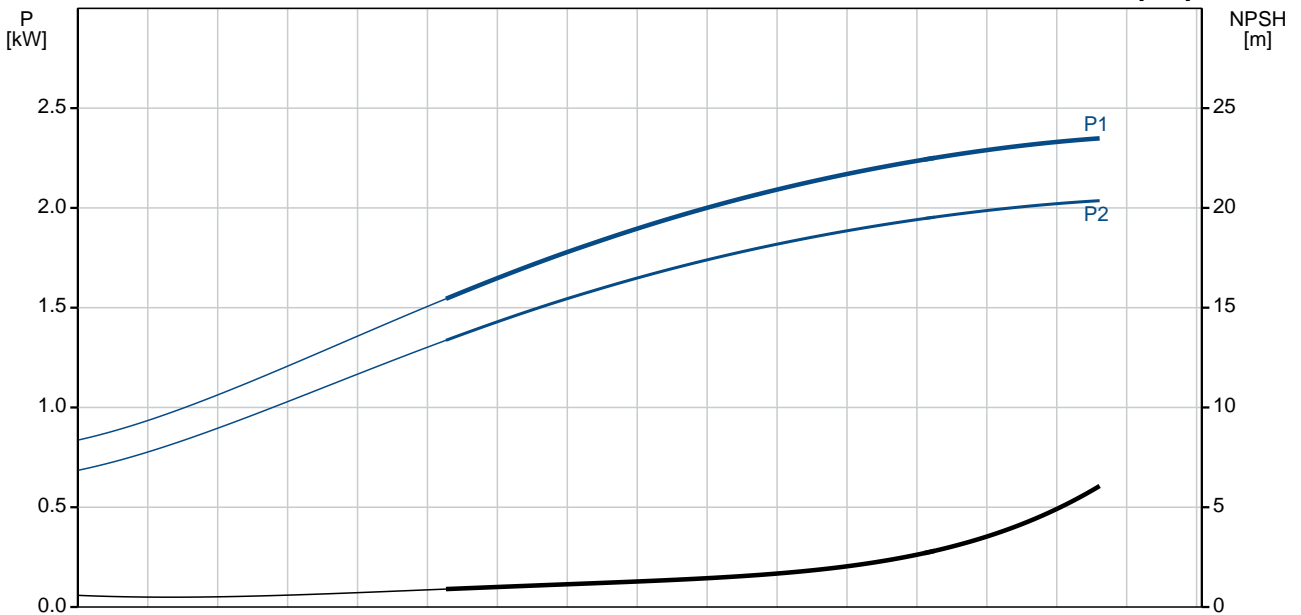
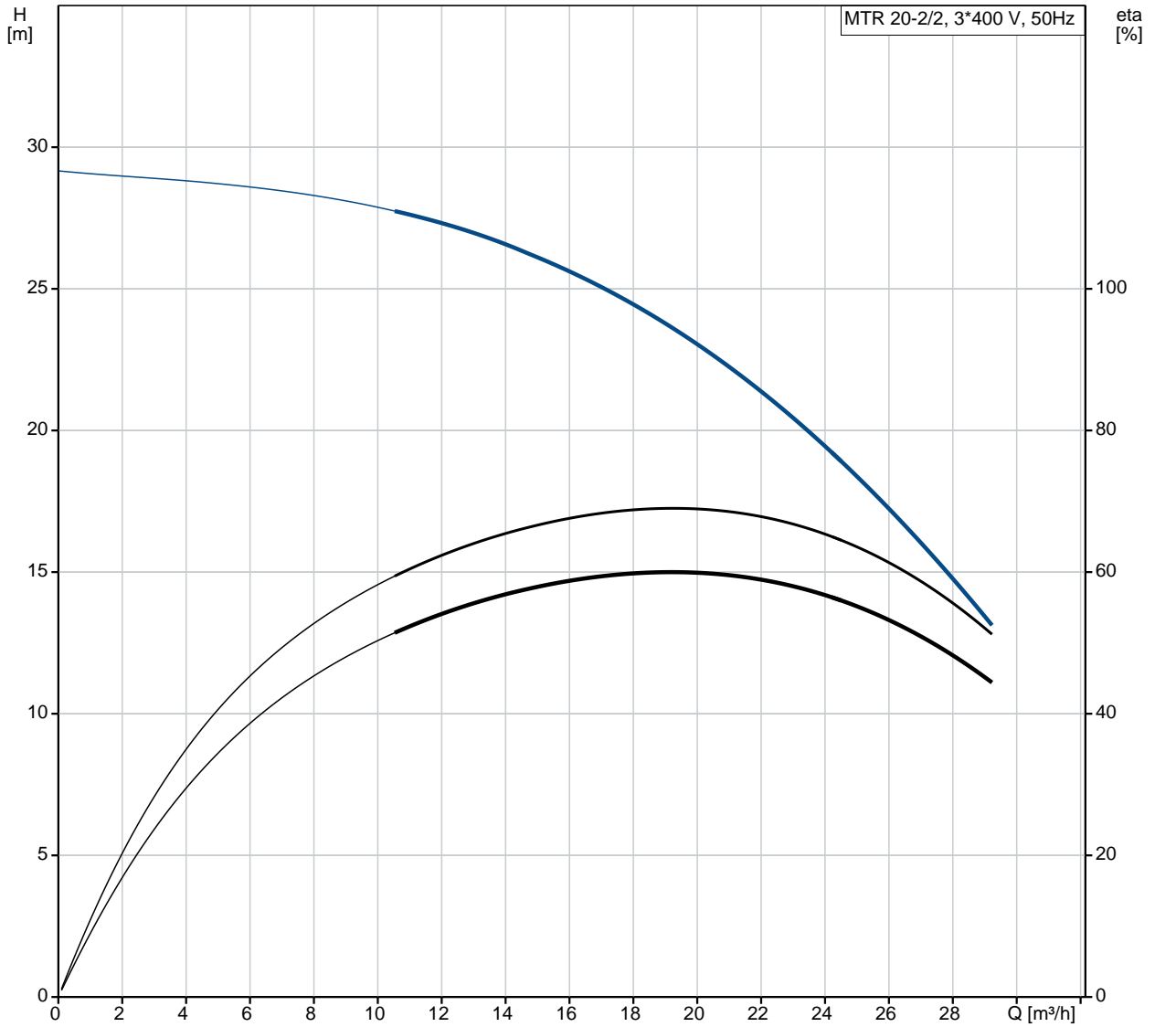

Description	Value
General information:	
Product name:	MTR 20-2/2 A-W-A-HUUV
Product No:	98513662
EAN number:	5711496393150 5711496393150
Price:	1.670,00 GBP
Technical:	
Pump speed on which pump data are based:	2899 rpm
Rated flow:	21 m ³ /h
Rated head:	22.3 m
Chambers:	2
Impellers:	2
Number of reduced-diameter impellers:	0
Drainage back to tank:	N
Pump orientation:	Vertical
Code for shaft seal:	HUUV
Curve tolerance:	ISO9906:2012 3B
Pump version:	A
Model:	A
Materials:	
Pump head:	Cast iron EN 1561 EN-GJL-200 ASTM A48-25B
Impeller:	Stainless steel EN 1.4301 AISI 304
Material code:	A
Installation:	
Maximum ambient temperature:	60 °C
Maximum operating pressure:	25 bar
Max pressure at stated temp:	25 bar / 90 °C
Type of connection:	G
Size of outlet connection:	2 inch
Immersion depth:	178 mm
Flange size for motor:	FT115
Connect code:	W
Liquid:	
Pumped liquid:	Water
Liquid temperature range:	-10 .. 90 °C
Selected liquid temperature:	20 °C
Density at selected liquid temperature:	998.2 kg/m ³
Electrical data:	
Motor standard:	IEC
Motor type:	90LC
IE Efficiency class:	IE3
Rated power - P2:	2.2 kW
Mains frequency:	50 Hz
Rated voltage:	3 x 380-415D V
Rated current:	4.45 A
Starting current:	850-950 %
Cos phi - power factor:	0.89-0.87
Rated speed:	2890-2910 rpm
Efficiency:	IE3 85,9%
Motor efficiency at full load:	85.9 %
Motor efficiency at 3/4 load:	86.8 %
Motor efficiency at 1/2 load:	86.0 %
Number of poles:	2

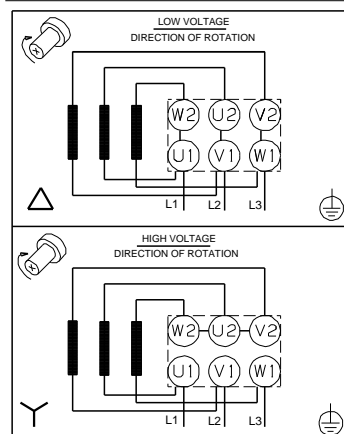
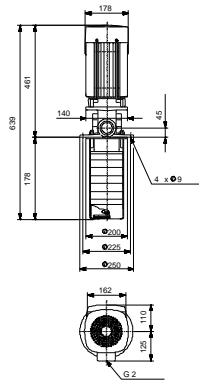
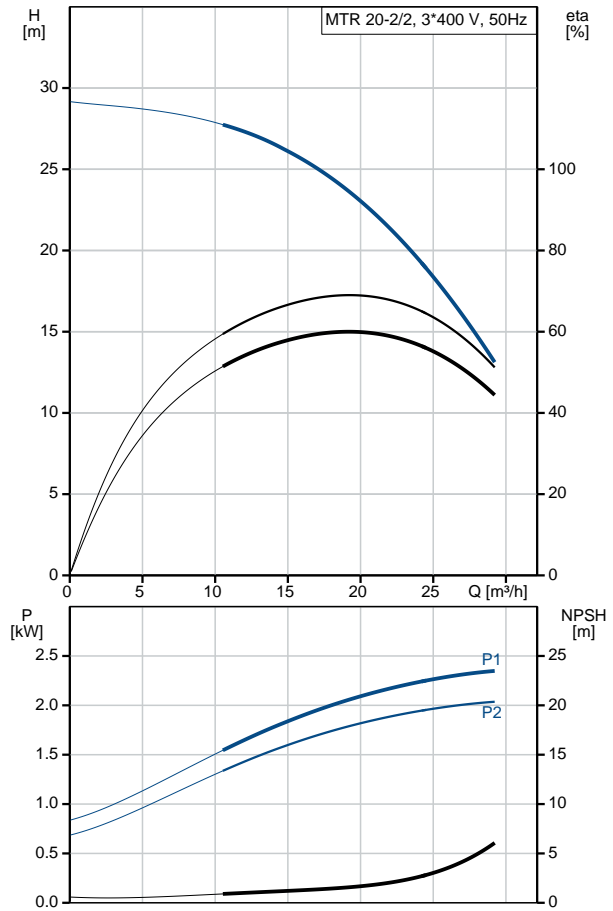



Company name:

Created by:

Phone:

Date:

15/10/2019

Description	Value
Enclosure class (IEC 34-5):	55 Dust/Jetting
Insulation class (IEC 85):	F
Motor protec:	NONE
Motor No:	85U15908
Controls:	
Frequency converter:	NONE
Others:	
Terminal box position:	6
Minimum efficiency index, MEI :	0.70
Net weight:	37 kg
Gross weight:	40.5 kg
Shipping volume:	0.08 m ³
Country of origin:	HU
Custom tariff no.:	84137075

98513662 MTR 20-2/2 A-W-A-HUUV 50 Hz

