

Qty.	Description
1	<p data-bbox="199 340 510 369">MTR 3-23/23 A-W-A-HUUV</p>  <p data-bbox="199 660 470 689">Product No.: 98511275</p> <p data-bbox="199 721 1173 779">Multistage, immersible, self-priming, centrifugal pump for vertical installation in tanks etc. The pump head and base are in cast iron – all other wetted parts are in stainless steel.</p> <p data-bbox="199 779 678 808">The pump has the following characteristics:</p> <ul data-bbox="239 808 1141 929" style="list-style-type: none"> • Installation length according to DIN 5440. • Impellers, intermediate chambers and spline shaft are made of Stainless steel. • Mechanical shaft seal according to EN 12756. • Power transmission via cast-iron split coupling. <p data-bbox="199 958 1189 1016">A cartridge shaft seal ensures high reliability, safe handling, and easy access and service. The pump is fitted with a 3-phase, fan-cooled asynchronous motor.</p> <p data-bbox="199 1108 638 1167">Controls: Frequency converter: NONE</p> <p data-bbox="199 1196 774 1344">Liquid: Pumped liquid: Water Liquid temperature range: -10 .. 90 °C Selected liquid temperature: 20 °C Density at selected liquid temperature: 998.2 kg/m³</p> <p data-bbox="199 1373 821 1641">Technical: Pump speed on which pump data are based: 2899 rpm Rated flow: 3 m³/h Rated head: 112.8 m Chambers: 23 Drainage back to tank: N Pump orientation: Vertical Code for shaft seal: HUUV Curve tolerance: ISO9906:2012 3B</p> <p data-bbox="199 1671 805 1877">Materials: Pump head: Cast iron EN 1561 EN-GJL-200 ASTM A48-25B Impeller: Stainless steel EN 1.4301 AISI 304</p> <p data-bbox="199 1906 726 2089">Installation: Maximum ambient temperature: 60 °C Maximum operating pressure: 25 bar Max pressure at stated temp: 25 bar / 90 °C Type of connection: G Size of outlet connection: 1 1/4 inch</p>

Qty.	Description
	Immersion depth: 538 mm Flange size for motor: FT115
	Electrical data:
	Motor standard: IEC
	Motor type: 90LC
	IE Efficiency class: IE3
	Rated power - P2: 2.2 kW
	Mains frequency: 50 Hz
	Rated voltage: 3 x 220-240D/380-415Y V
	Rated current: 7.70/4.45 A
	Starting current: 850-950 %
	Cos phi - power factor: 0.89-0.87
	Rated speed: 2890-2910 rpm
	Efficiency: IE3 85,9%
	Motor efficiency at full load: 85.9 %
	Motor efficiency at 3/4 load: 86.8 %
	Motor efficiency at 1/2 load: 86.0 %
	Number of poles: 2
	Enclosure class (IEC 34-5): 55 Dust/Jetting
	Insulation class (IEC 85): F
	Motor No: 85U05908
	Others:
	Terminal box position: 6
	Minimum efficiency index, MEI : 0.70
	Net weight: 28.4 kg
	Gross weight: 32.4 kg
	Shipping volume: 0.1 m ³
	Country of origin: HU
	Custom tariff no.: 84137075

98511275 MTR 3-23/23 A-W-A-HUUV 50 Hz

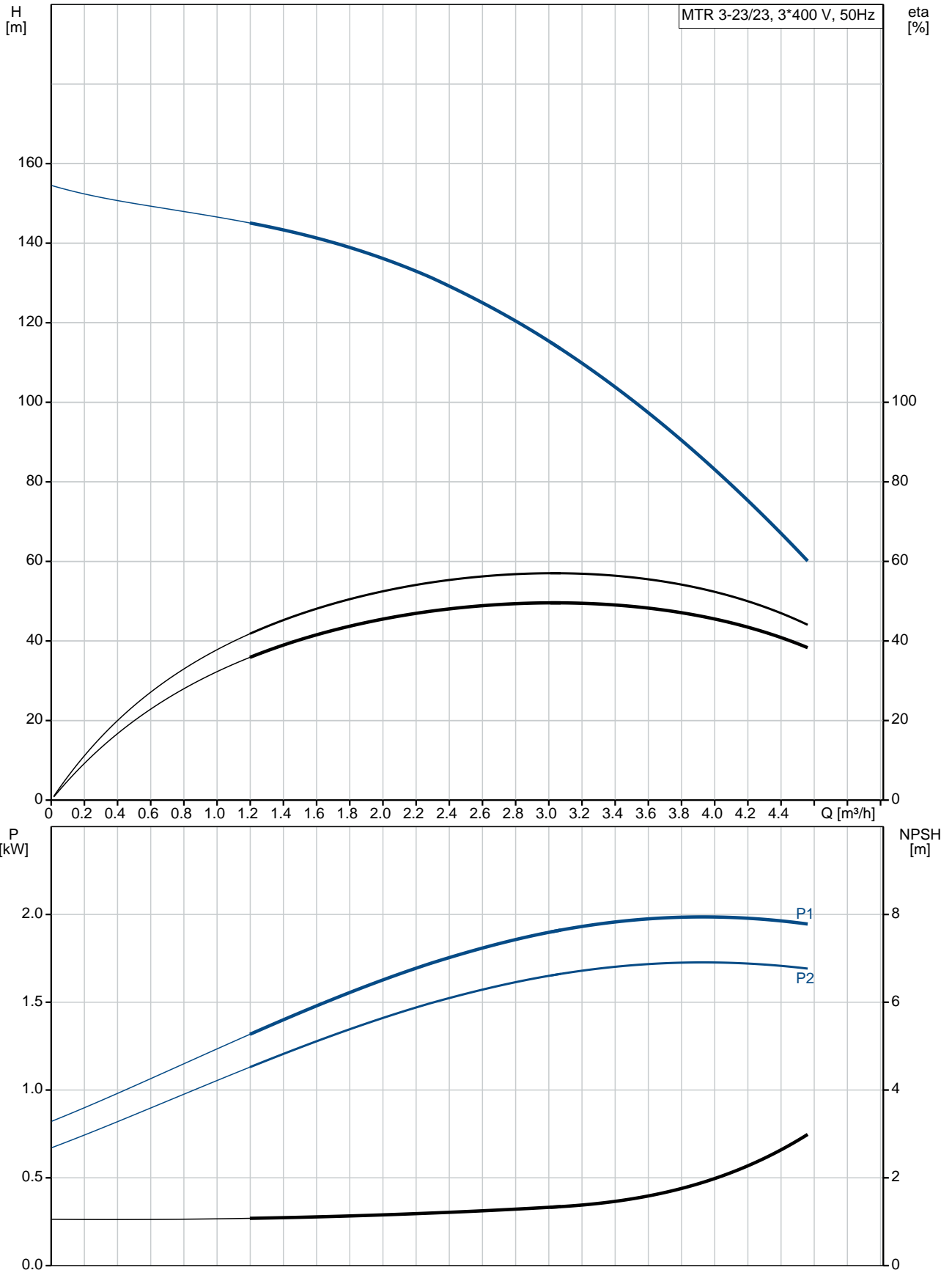

Description	Value
General information:	
Product name:	MTR 3-23/23 A-W-A-HUUV
Product No:	98511275
EAN number:	5711496360473 5711496360473
Price:	1.633,00 GBP
Technical:	
Pump speed on which pump data are based:	2899 rpm
Rated flow:	3 m ³ /h
Rated head:	112.8 m
Chambers:	23
Impellers:	23
Number of reduced-diameter impellers:	0
Drainage back to tank:	N
Pump orientation:	Vertical
Code for shaft seal:	HUUV
Curve tolerance:	ISO9906:2012 3B
Pump version:	A
Model:	A
Materials:	
Pump head:	Cast iron EN 1561 EN-GJL-200 ASTM A48-25B
Impeller:	Stainless steel EN 1.4301 AISI 304
Material code:	A
Installation:	
Maximum ambient temperature:	60 °C
Maximum operating pressure:	25 bar
Max pressure at stated temp:	25 bar / 90 °C
Type of connection:	G
Size of outlet connection:	1 1/4 inch
Immersion depth:	538 mm
Flange size for motor:	FT115
Connect code:	W
Liquid:	
Pumped liquid:	Water
Liquid temperature range:	-10 .. 90 °C
Selected liquid temperature:	20 °C
Density at selected liquid temperature:	998.2 kg/m ³
Electrical data:	
Motor standard:	IEC
Motor type:	90LC
IE Efficiency class:	IE3
Rated power - P2:	2.2 kW
Mains frequency:	50 Hz
Rated voltage:	3 x 220-240D/380-415Y V
Rated current:	7.70/4.45 A
Starting current:	850-950 %
Cos phi - power factor:	0.89-0.87
Rated speed:	2890-2910 rpm
Efficiency:	IE3 85,9%
Motor efficiency at full load:	85.9 %
Motor efficiency at 3/4 load:	86.8 %
Motor efficiency at 1/2 load:	86.0 %

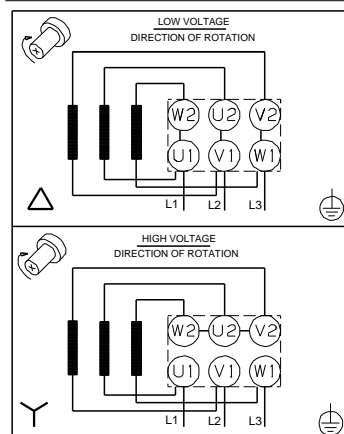
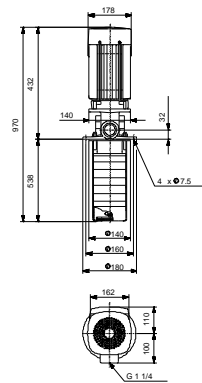
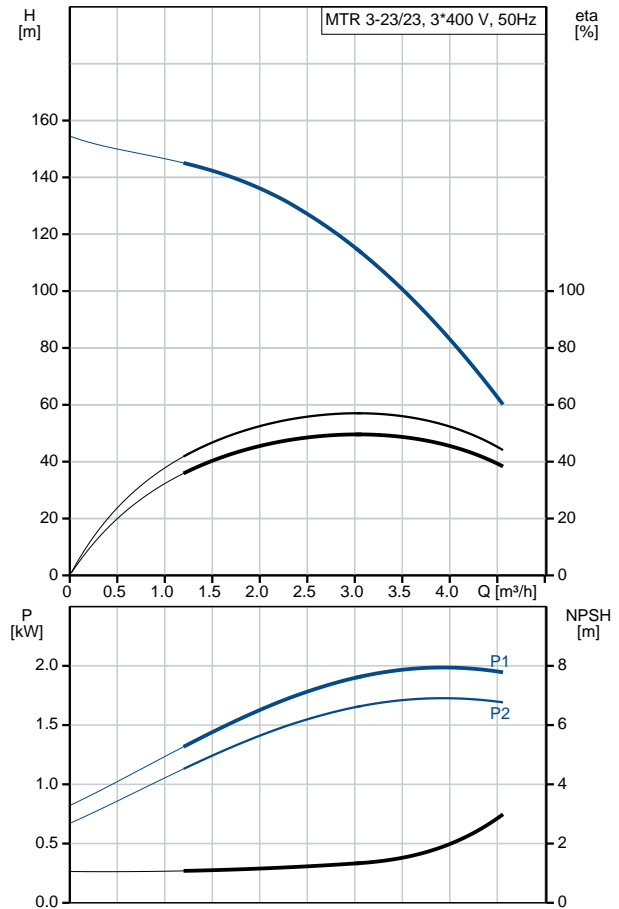



Company name:

Created by:

Phone:

Date:

15/10/2019

Description	Value
Number of poles:	2
Enclosure class (IEC 34-5):	55 Dust/Jetting
Insulation class (IEC 85):	F
Motor protec:	NONE
Motor No:	85U05908
Controls:	
Frequency converter:	NONE
Others:	
Terminal box position:	6
Minimum efficiency index, MEI :	0.70
Net weight:	28.4 kg
Gross weight:	32.4 kg
Shipping volume:	0.1 m ³
Country of origin:	HU
Custom tariff no.:	84137075

98511275 MTR 3-23/23 A-W-A-HUUV 50 Hz

