

Qty. Description

1 TPE2 40-150-N A-F-A-BQQE



Product No.: [98438345](#)

Single-stage, close-coupled, volute pump with in-line suction and discharge ports of identical diameter. The pump is of the top-pull-out design, i.e. the power head (motor, pump head and impeller) can be removed for maintenance or service while the pump housing remains in the pipework.

The shaft seal is according to EN 12756. Pipework connection is via PN 6/10 DIN flanges (EN 1092-2 and ISO 7005-2).

The pump is fitted with a fan-cooled, permanent-magnet synchronous motor. The motor efficiency is classified as IE5 in accordance with IEC 60034-30-2.

The motor includes a frequency converter and PI controller in the motor terminal box. This enables continuously variable control of the motor speed, which again enables adaptation of the performance to a given requirement.

Controls:

Frequency converter: Built-in

Liquid:

Pumped liquid: Water
 Liquid temperature range: -25 .. 120 °C
 Liquid temperature during operation: 20 °C
 Density: 998.2 kg/m³

Technical:

Pump speed on which pump data are based: 3900 rpm
 Rated flow: 16.1 m³/h
 Rated head: 9.3 m
 Actual impeller diameter: 74 mm
 Primary shaft seal: BQQE
 Curve tolerance: ISO9906:2012 3B

Materials:

Pump housing: Cast iron
 EN-JL1040
 ASTM A48-40 B
 Impeller: Composite PES/PP 30% GF

Installation:

Range of ambient temperature: -20 .. 50 °C
 Maximum operating pressure: 10 bar
 Flange standard: DIN
 Pipe connection: DN 40
 Pressure rating: PN 6/10
 Port-to-port length: 250 mm
 Flange size for motor: 56C

Electrical data:

Motor type: 71A
 IE Efficiency class: IE5
 Rated power - P2: 0.55 kW

Qty.	Description
------	-------------

Mains frequency:	50 Hz
Rated voltage:	1 x 200-240 V
Rated current:	3.45-2.90 A
Cos phi - power factor:	0.98
Rated speed:	360-4000 rpm
Efficiency:	85.3%
Motor efficiency at full load:	85.3 %
Enclosure class (IEC 34-5):	IP55
Insulation class (IEC 85):	F

Others:

Minimum efficiency index, MEI =:	0.7
ErP status:	EuP Standalone/Prod.
Net weight:	22.7 kg
Gross weight:	29.9 kg
Shipping volume:	0.1 m ³
Danish VVS No.:	382201150
Country of origin:	HU
Custom tariff no.:	84137051

98438345 TPE2 40-150-N A-F-A-BQQE 50 Hz

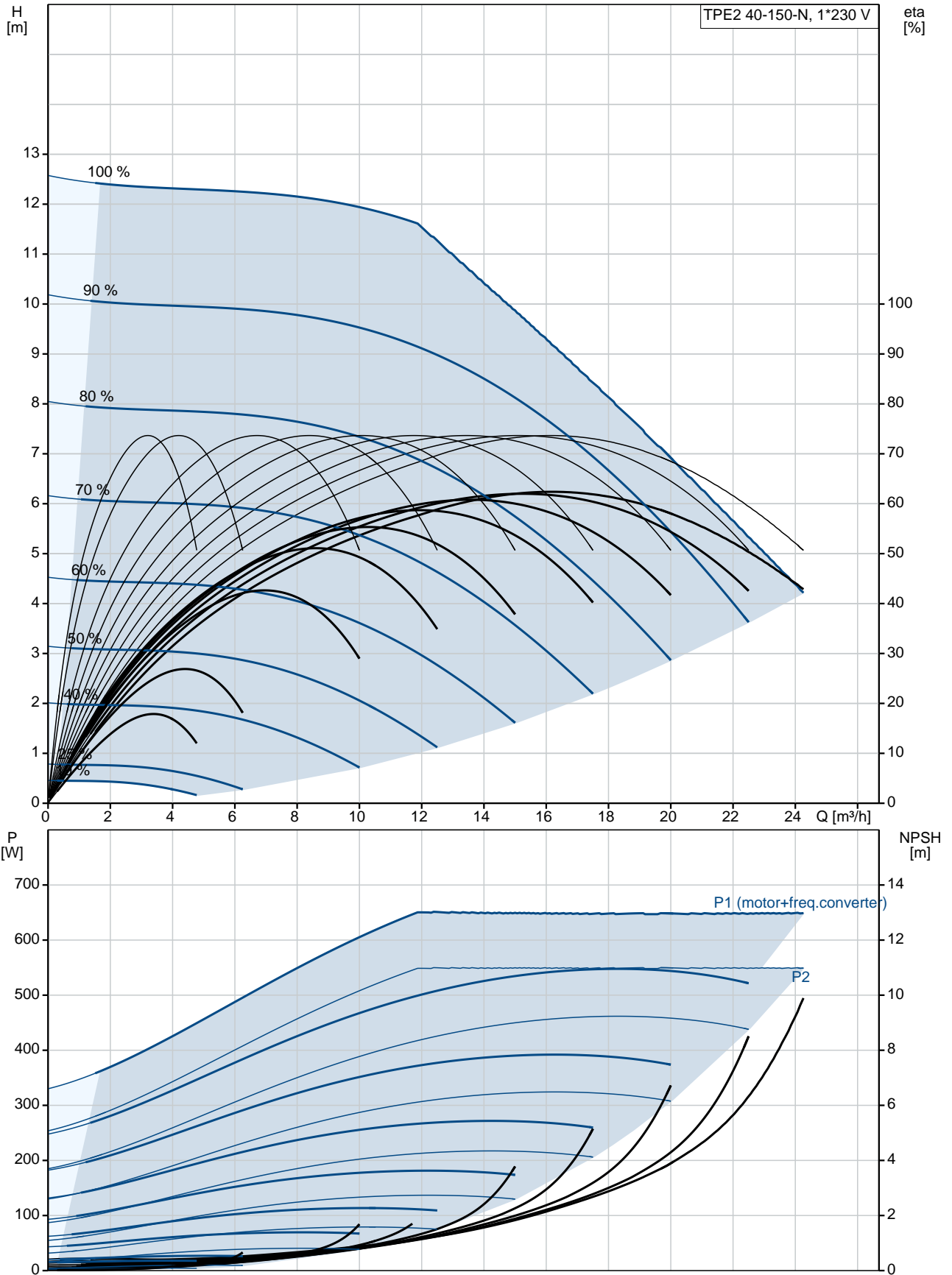

Description	Value
General information:	
Product name:	TPE2 40-150-N A-F-A-BQQE
Product No:	98438345
EAN number:	5711495017132
Price:	2.252,00 GBP
Technical:	
Pump speed on which pump data are based:	3900 rpm
Rated flow:	16.1 m ³ /h
Rated head:	9.3 m
Head max:	150 dm
Actual impeller diameter:	74 mm
Primary shaft seal:	BQQE
Curve tolerance:	ISO9906:2012 3B
Pump version:	A
Model:	A
Materials:	
Pump housing:	Cast iron
	EN-JL1040
	ASTM A48-40 B
Impeller:	Composite PES/PP 30% GF
Material code:	A
Installation:	
Range of ambient temperature:	-20 .. 50 °C
Maximum operating pressure:	10 bar
Flange standard:	DIN
Pipe connection:	DN 40
Pressure rating:	PN 6/10
Port-to-port length:	250 mm
Flange size for motor:	56C
Connect code:	F
Liquid:	
Pumped liquid:	Water
Liquid temperature range:	-25 .. 120 °C
Liquid temperature during operation:	20 °C
Density:	998.2 kg/m ³
Electrical data:	
Motor type:	71A
IE Efficiency class:	IE5
Rated power - P2:	0.55 kW
Mains frequency:	50 Hz
Rated voltage:	1 x 200-240 V
Rated current:	3.45-2.90 A
Cos phi - power factor:	0.98
Rated speed:	360-4000 rpm
Efficiency:	85.3%
Motor efficiency at full load:	85.3 %
Enclosure class (IEC 34-5):	IP55
Insulation class (IEC 85):	F
Motor protec:	YES
Motor No:	99137993
Controls:	
Control panel:	HMI200 - Standard
Function Module:	FM300 - Advanced
Frequency converter:	Built-in
Others:	
Minimum efficiency index, MEI =:	0.7
ErP status:	EuP Standalone/Prod.

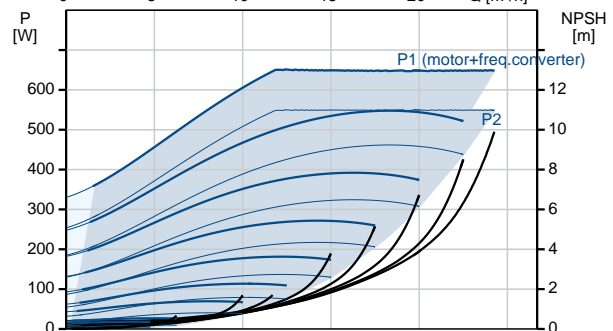
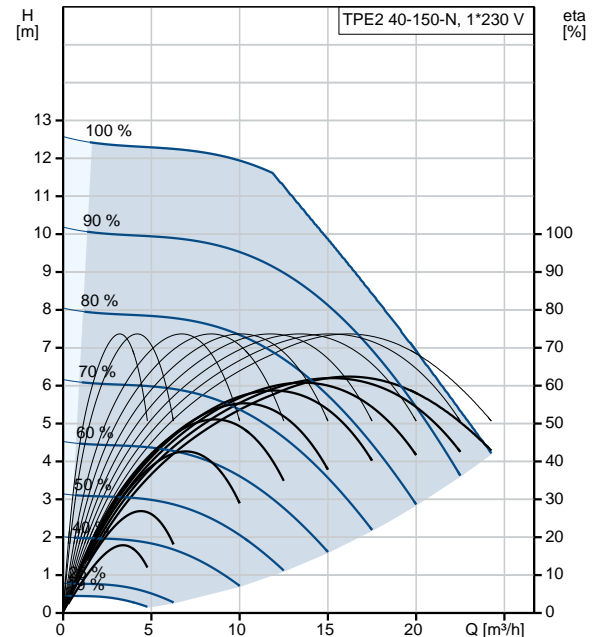



Company name:

Created by:

Phone:

Date: 21/12/2018

Description	Value
Net weight:	22.7 kg
Gross weight:	29.9 kg
Shipping volume:	0.1 m ³
Config. file no:	98819170
Danish VVS No.:	382201150
Country of origin:	HU
Custom tariff no.:	84137051

98438345 TPE2 40-150-N A-F-A-BQQE 50 Hz

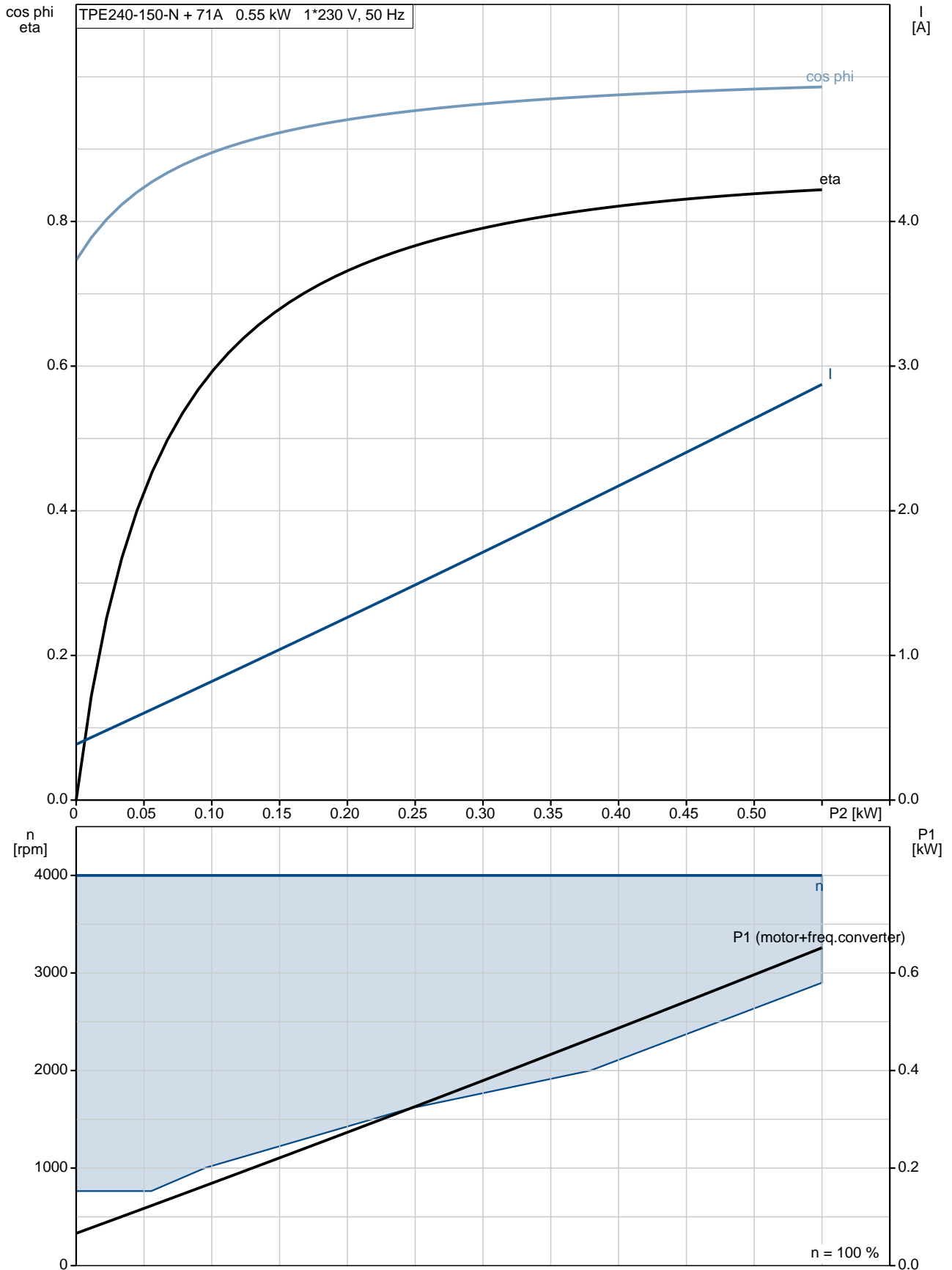

98438345 TPE2 40-150-N A-F-A-BQQE 50 Hz

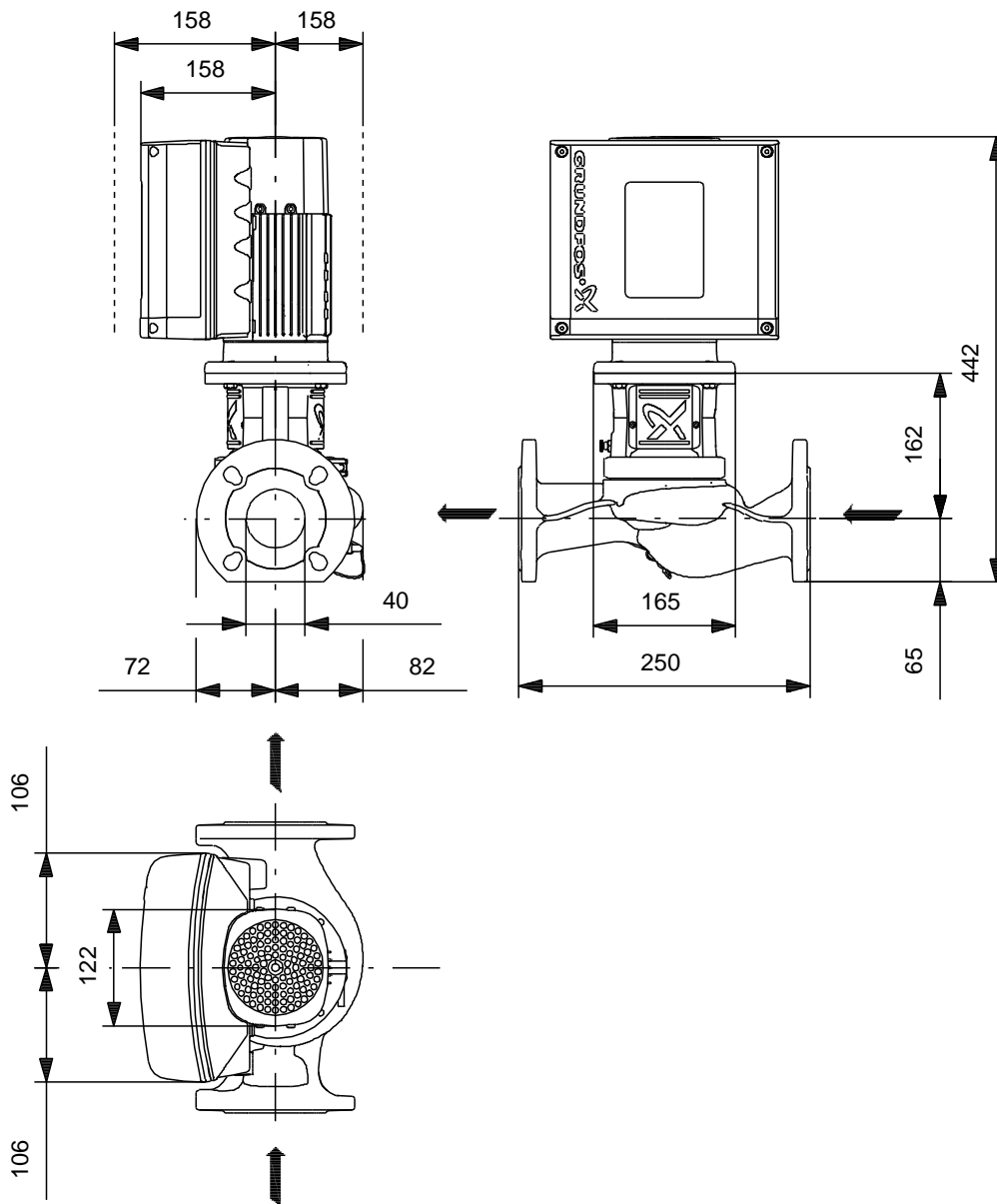

Note! All units are in [mm] unless others are stated.
Disclaimer: This simplified dimensional drawing does not show all details.

98438345 TPE2 40-150-N A-F-A-BQQE 50 Hz

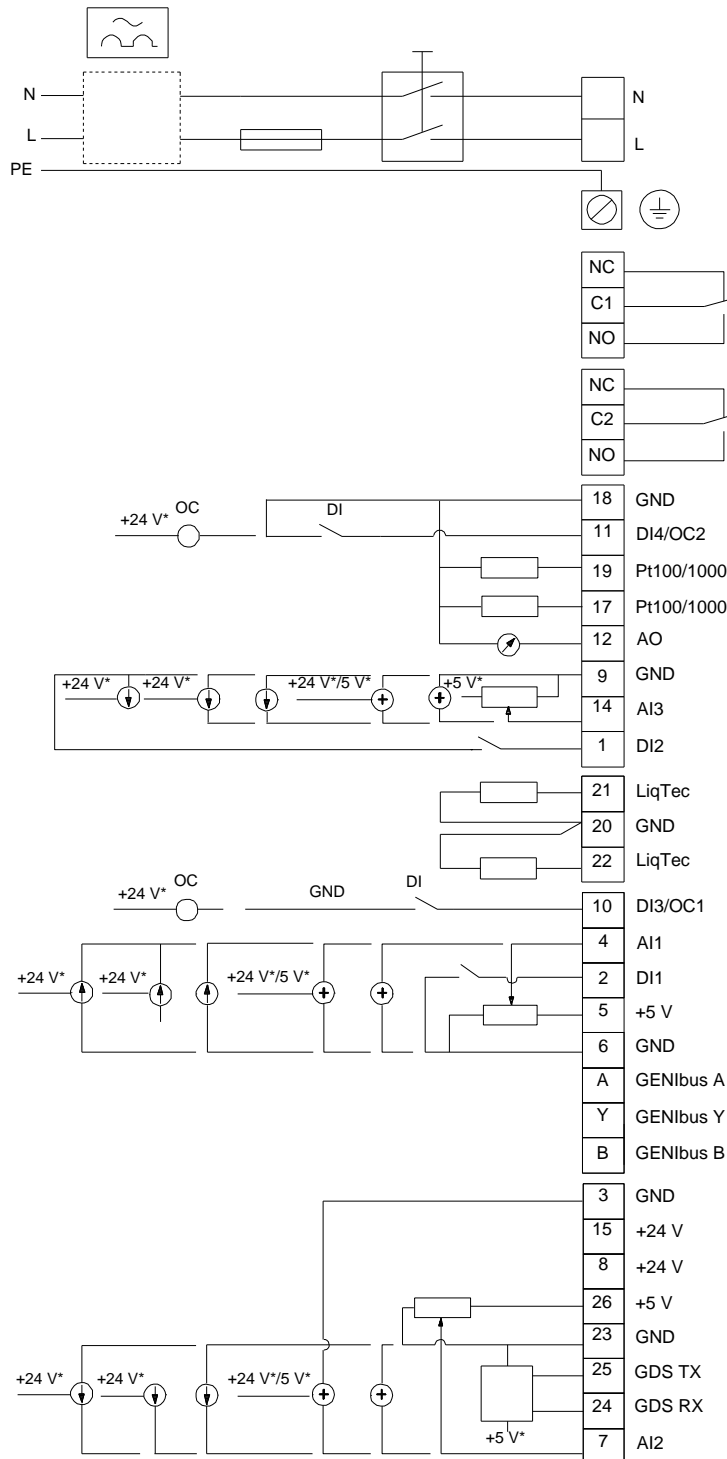

Note! All units are in [mm] unless others are stated.