

Qty. Description

1 NB 32-125.1/100 AF2ABQQE



Product No.: [98127503](#)

Non-self-priming, single-stage, centrifugal volute pump designed according to ISO 5199 with dimensions and rated performance according to EN 733 (10 bar).

Flanges are PN 16 with dimensions according to EN 1092-2. The pump has an axial suction port, radial discharge port, horizontal shaft and a back pull-out design enabling removal of the motor, motor stool, cover and impeller without disturbing the pump housing or pipework.

The unbalanced rubber bellows seal is according to DIN EN 12756.

The pump is close-coupled to a fan-cooled asynchronous motor.

Controls:

Frequency converter: NONE

Liquid:

Pumped liquid: Water
 Liquid temperature range: -25 .. 120 °C
 Liquid temperature during operation: 20 °C
 Density: 998.2 kg/m³

Technical:

Rated flow: 14.9 m³/h
 Rated head: 9.782 m
 Actual impeller diameter: 100 mm
 Nominal impeller diameter: 125.1 mm
 Shaft seal arrangement: Single
 Code for shaft seal: BQQE
 Curve tolerance: ISO9906:2012 3B

Materials:

Pump housing: Cast iron
 EN-GJL-250
 ASTM class 35
 Wear ring: Brass
 Impeller: Cast iron
 EN-GJL-200
 ASTM class 30
 Shaft: Stainless steel
 EN 1.4301
 AISI 304

Installation:

Maximum ambient temperature: 60 °C
 Maximum operating pressure: 16 bar
 Pipe connection standard: EN 1092-2
 Size of inlet connection: DN 50
 Size of outlet connection: DN 32
 Pressure rating for pipe connection: PN 16
 Pump housing with feet: Y

Qty.	Description
	<p>Support block: N</p> <p>Electrical data:</p> <p>IE Efficiency class: IE3</p> <p>P2: 0.75 kW</p> <p>Mains frequency: 50 Hz</p> <p>Rated voltage: 3 x 220-240D/380-415Y V</p> <p>Rated current: 3.30/1.90 A</p> <p>Starting current: 580-620 %</p> <p>Cos phi - power factor: 0.81-0.71</p> <p>Rated speed: 2840-2870 rpm</p> <p>Efficiency: IE3 80,7%</p> <p>Motor efficiency at full load: 80.7 %</p> <p>Motor efficiency at 3/4 load: 82.7 %</p> <p>Motor efficiency at 1/2 load: 81.7 %</p> <p>Number of poles: 2</p> <p>Enclosure class (IEC 34-5): 55 Dust/Jetting</p> <p>Insulation class (IEC 85): F</p> <p>Others:</p> <p>Minimum efficiency index, MEI $\hat{\%}$: 0.70</p> <p>Net weight: 32 kg</p> <p>Gross weight: 43 kg</p> <p>Shipping volume: 0.134 m³</p> <p>Country of origin: HU</p> <p>Custom tariff no.: 84137051</p>

98127503 NB 32-125.1/100 AF2ABQQE 50 Hz

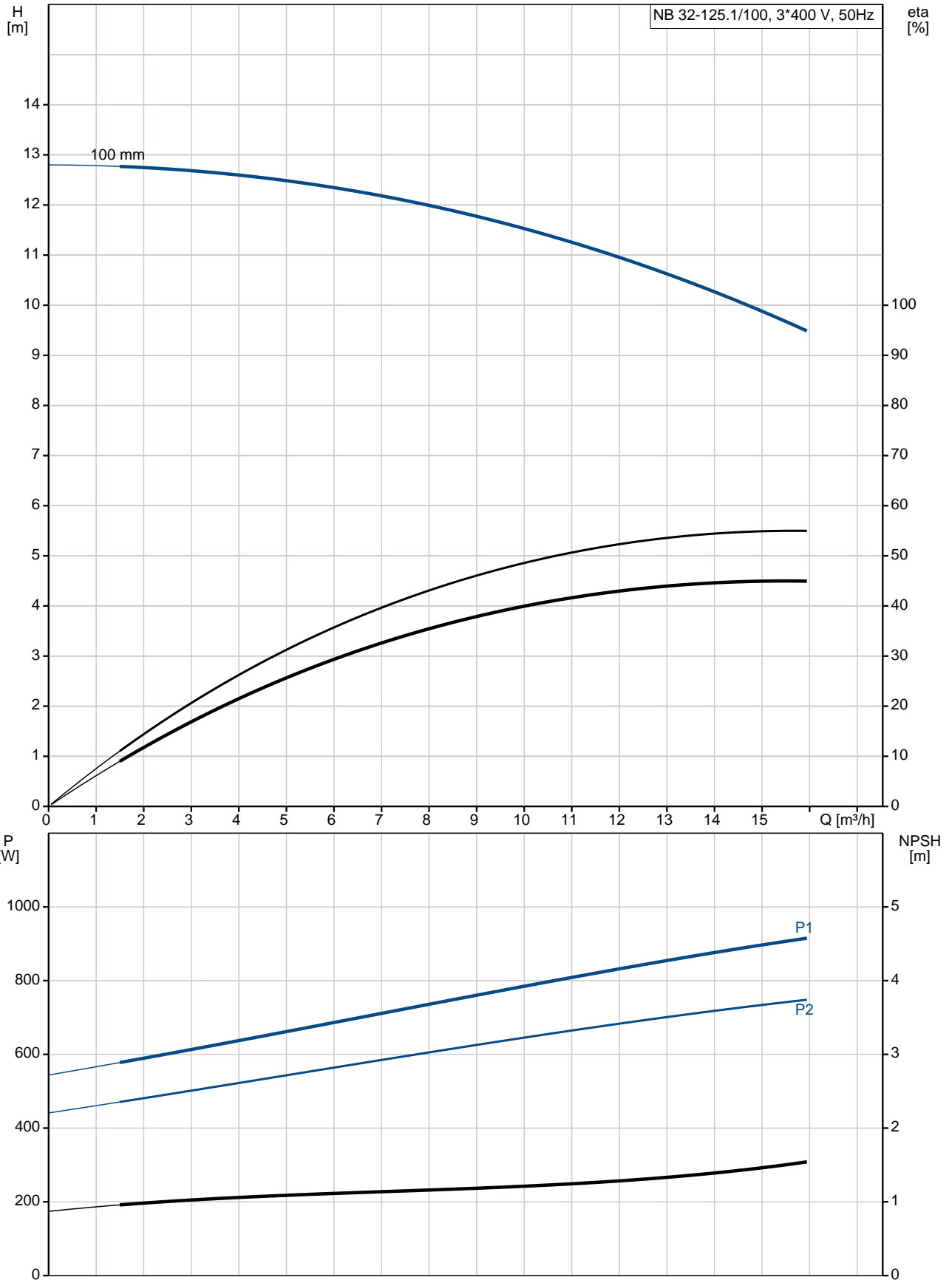

Description	Value
General information:	
Product name:	NB 32-125.1/100 AF2ABQQE
Product No:	98127503
EAN number:	5711490012866
Price:	1.145,00 GBP
Technical:	
Rated flow:	14.9 m ³ /h
Rated head:	9.782 m
Actual impeller diameter:	100 mm
Nominal impeller diameter:	125.1 mm
Shaft seal arrangement:	Single
Shaft diameter:	24 mm
Code for shaft seal:	BQQE
Curve tolerance:	ISO9906:2012 3B
Pump version:	A
Materials:	
Pump housing:	Cast iron
	EN-GJL-250
	ASTM class 35
Wear ring:	Brass
Impeller:	Cast iron
	EN-GJL-200
	ASTM class 30
Shaft:	Stainless steel
	EN 1.4301
	AISI 304
Material code:	A
Installation:	
Maximum ambient temperature:	60 °C
Maximum operating pressure:	16 bar
Pipe connection standard:	EN 1092-2
Size of inlet connection:	DN 50
Size of outlet connection:	DN 32
Pressure rating for pipe connection:	PN 16
Pump housing with feet:	Y
Support block:	N
Connect code:	F2
Liquid:	
Pumped liquid:	Water
Liquid temperature range:	-25 .. 120 °C
Liquid temperature during operation:	20 °C
Density:	998.2 kg/m ³
Electrical data:	
IE Efficiency class:	IE3
P2:	0.75 kW
Mains frequency:	50 Hz
Rated voltage:	3 x 220-240D/380-415Y V
Rated current:	3.30/1.90 A
Starting current:	580-620 %
Cos phi - power factor:	0.81-0.71
Rated speed:	2840-2870 rpm
Efficiency:	IE3 80,7%
Motor efficiency at full load:	80.7 %
Motor efficiency at 3/4 load:	82.7 %
Motor efficiency at 1/2 load:	81.7 %
Number of poles:	2
Enclosure class (IEC 34-5):	55 Dust/Jetting

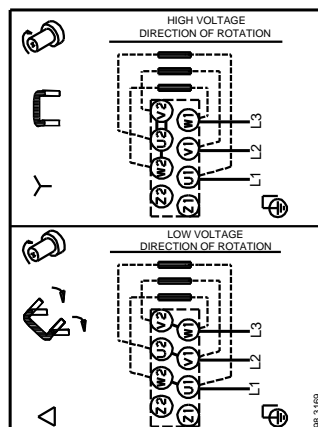
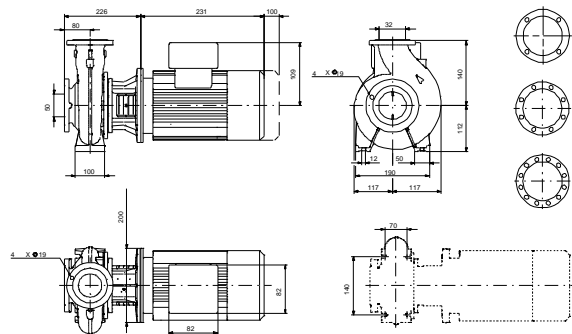
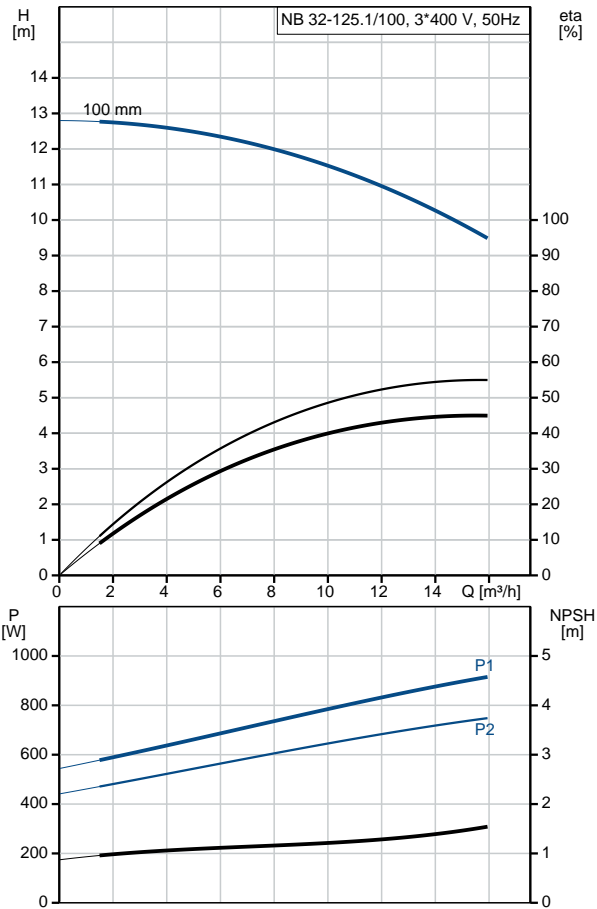



Company name:

Created by:

Phone:

Date:

21/03/2019

Description	Value
Insulation class (IEC 85):	F
Motor protec:	NONE
Motor No:	87120283
Mount. design. acc. IEC 34-7:	IM V1/B5
Controls:	
Frequency converter:	NONE
Others:	
Minimum efficiency index, MEI $\eta_{\%}$:	0.70
Net weight:	32 kg
Gross weight:	43 kg
Shipping volume:	0.134 m ³
Country of origin:	HU
Custom tariff no.:	84137051

98127503 NB 32-125.1/100 AF2ABQQE 50 Hz

