

Qty.	Description
1	<p data-bbox="199 338 518 369"><b>NB 50-125/121 AF2ABQQE</b></p> <div data-bbox="284 459 513 593" style="text-align: center;">  </div> <p data-bbox="199 660 470 692">Product No.: <a href="#">97933643</a></p> <p data-bbox="199 719 1460 772">Non-self-priming, single-stage, centrifugal volute pump designed according to ISO 5199 with dimensions and rated performance according to EN 733 (10 bar).</p> <p data-bbox="199 806 1452 884">Flanges are PN 16 with dimensions according to EN 1092-2. The pump has an axial suction port, radial discharge port, horizontal shaft and a back pull-out design enabling removal of the motor, motor stool, cover and impeller without disturbing the pump housing or pipework.</p> <p data-bbox="199 896 941 927">The unbalanced rubber bellows seal is according to DIN EN 12756.</p> <p data-bbox="199 927 909 958">The pump is close-coupled to a fan-cooled asynchronous motor.</p> <p data-bbox="199 981 319 1012"><b>Controls:</b></p> <p data-bbox="199 1012 638 1043">Frequency converter: NONE</p> <p data-bbox="199 1070 295 1102"><b>Liquid:</b></p> <p data-bbox="199 1102 638 1133">Pumped liquid: Water</p> <p data-bbox="199 1133 710 1164">Liquid temperature range: -25 .. 120 °C</p> <p data-bbox="199 1164 694 1196">Liquid temperature during operation: 20 °C</p> <p data-bbox="199 1196 702 1227">Density: 998.2 kg/m<sup>3</sup></p> <p data-bbox="199 1249 327 1281"><b>Technical:</b></p> <p data-bbox="199 1281 678 1312">Rated flow: 69.5 m<sup>3</sup>/h</p> <p data-bbox="199 1312 646 1344">Rated head: 14.4 m</p> <p data-bbox="199 1344 662 1375">Actual impeller diameter: 121 mm</p> <p data-bbox="199 1375 662 1406">Nominal impeller diameter: 125 mm</p> <p data-bbox="199 1406 638 1438">Shaft seal arrangement: Single</p> <p data-bbox="199 1438 638 1469">Code for shaft seal: BQQE</p> <p data-bbox="199 1469 766 1500">Curve tolerance: ISO9906:2012 3B</p> <p data-bbox="199 1523 327 1554"><b>Materials:</b></p> <p data-bbox="199 1554 742 1635">Pump housing: Cast iron EN-GJL-250 ASTM class 35</p> <p data-bbox="199 1635 638 1666">Wear ring: Brass</p> <p data-bbox="199 1666 742 1747">Impeller: Cast iron EN-GJL-200 ASTM class 30</p> <p data-bbox="199 1747 734 1848">Shaft: Stainless steel EN 1.4301 AISI 304</p> <p data-bbox="199 1870 343 1901"><b>Installation:</b></p> <p data-bbox="199 1901 630 1933">Maximum ambient temperature: 60 °C</p> <p data-bbox="199 1933 646 1964">Maximum operating pressure: 16 bar</p> <p data-bbox="199 1964 694 1995">Pipe connection standard: EN 1092-2</p> <p data-bbox="199 1995 638 2027">Size of inlet connection: DN 65</p> <p data-bbox="199 2027 638 2058">Size of outlet connection: DN 50</p> <p data-bbox="199 2058 694 2089">Pressure rating for pipe connection: PN 16</p> <p data-bbox="199 2089 582 2121">Pump housing with feet: Y</p>

Qty.	Description
	Support block: N
	<b>Electrical data:</b>
	IE Efficiency class: IE3
	P2: 4 kW
	Mains frequency: 50 Hz
	Rated voltage: 3 x 380-415D V
	Rated current: 7.9 A
	Starting current: 1000-1110 %
	Cos phi - power factor: 0.87-0.87
	Rated speed: 2920-2940 rpm
	Efficiency: IE3 88,1%
	Motor efficiency at full load: 88.1 %
	Motor efficiency at 3/4 load: 88.6 %
	Motor efficiency at 1/2 load: 85.2 %
	Number of poles: 2
	Enclosure class (IEC 34-5): 55 Dust/Jetting
	Insulation class (IEC 85): F
	<b>Others:</b>
	Minimum efficiency index, MEI $\hat{\%}$ : 0.70
	Net weight: 68 kg
	Gross weight: 78 kg
	Shipping volume: 0.178 m <sup>3</sup>
	Country of origin: HU
	Custom tariff no.: 84137051

## 97933643 NB 50-125/121 AF2ABQQE 50 Hz

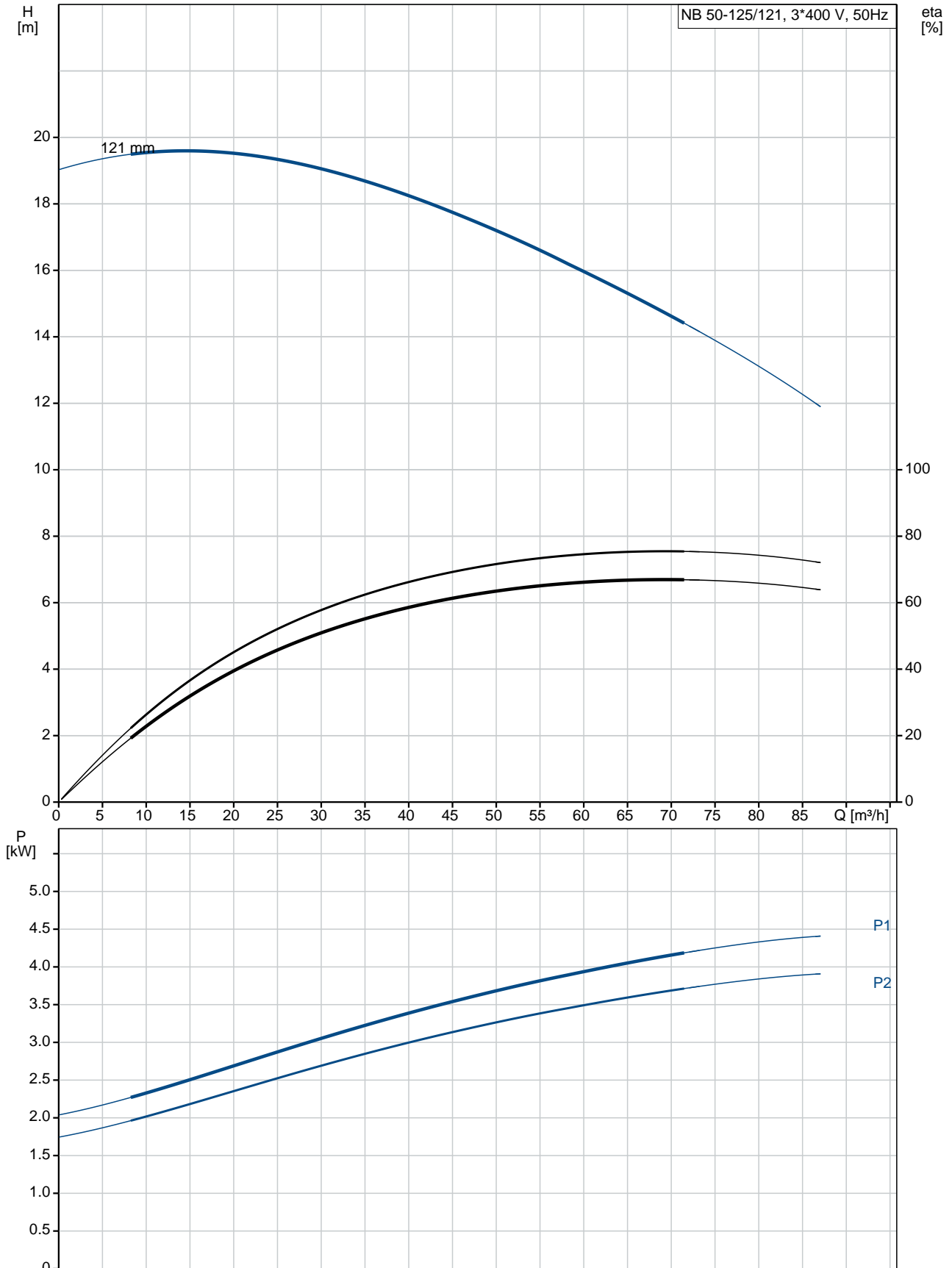

Description	Value
<b>General information:</b>	
Product name:	NB 50-125/121 AF2ABQQE
Product No:	97933643
EAN number:	5710626688708
Price:	1.865,00 GBP
<b>Technical:</b>	
Rated flow:	69.5 m <sup>3</sup> /h
Rated head:	14.4 m
Actual impeller diameter:	121 mm
Nominal impeller diameter:	125 mm
Shaft seal arrangement:	Single
Shaft diameter:	24 mm
Code for shaft seal:	BQQE
Curve tolerance:	ISO9906:2012 3B
Pump version:	A
<b>Materials:</b>	
Pump housing:	Cast iron EN-GJL-250 ASTM class 35
Wear ring:	Brass
Impeller:	Cast iron EN-GJL-200 ASTM class 30
Shaft:	Stainless steel EN 1.4301 AISI 304
Material code:	A
<b>Installation:</b>	
Maximum ambient temperature:	60 °C
Maximum operating pressure:	16 bar
Pipe connection standard:	EN 1092-2
Size of inlet connection:	DN 65
Size of outlet connection:	DN 50
Pressure rating for pipe connection:	PN 16
Pump housing with feet:	Y
Support block:	N
Connect code:	F2
<b>Liquid:</b>	
Pumped liquid:	Water
Liquid temperature range:	-25 .. 120 °C
Liquid temperature during operation:	20 °C
Density:	998.2 kg/m <sup>3</sup>
<b>Electrical data:</b>	
IE Efficiency class:	IE3
P2:	4 kW
Mains frequency:	50 Hz
Rated voltage:	3 x 380-415D V
Rated current:	7.9 A
Starting current:	1000-1110 %
Cos phi - power factor:	0.87-0.87
Rated speed:	2920-2940 rpm
Efficiency:	IE3 88,1%
Motor efficiency at full load:	88.1 %
Motor efficiency at 3/4 load:	88.6 %
Motor efficiency at 1/2 load:	85.2 %
Number of poles:	2
Enclosure class (IEC 34-5):	55 Dust/Jetting
Insulation class (IEC 85):	F

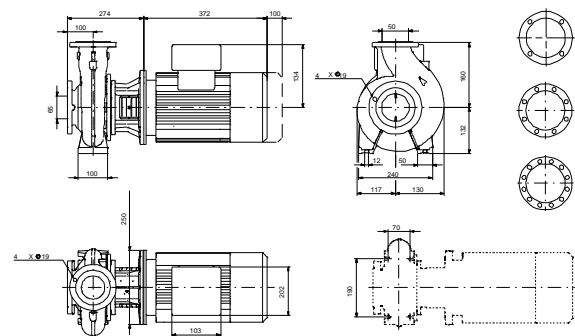
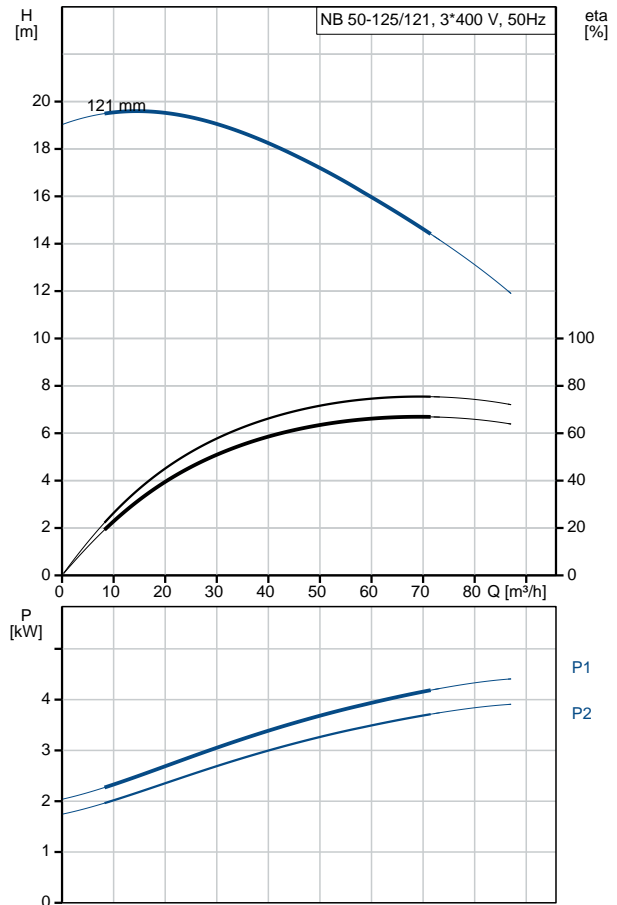



Company name:

Created by:

Phone:

Date:

21/03/2019

Description	Value
Motor protec:	PTC
Motor No:	87322303
Mount. design. acc. IEC 34-7:	IM V1/B5
<b>Controls:</b>	
Frequency converter:	NONE
<b>Others:</b>	
Minimum efficiency index, MEI $\eta_{\%}$ :	0.70
Net weight:	68 kg
Gross weight:	78 kg
Shipping volume:	0.178 m <sup>3</sup>
Country of origin:	HU
Custom tariff no.:	84137051

## 97933643 NB 50-125/121 AF2ABQQE 50 Hz

