

**Qty. Description**

1 SOLOLIFT2 D-2



Note! Product picture may differ from actual product

Product No.: [97775333](#)

Sololift2 D-2 is a small, compact automatic lifting station suitable for pumping of wastewater off places in private dwellings where greywater (w/o faeces) cannot be led directly to the sewer by means of a natural downward slope.

Sololift2 D-2 is typically used for:

- cabinet showers, washbasins or bidets in basements below sewer level, in connection with the renovation or modernisation of existing buildings, where the location may be remote from the main soil pipe so that a natural slope cannot be established.

Extremely low switching levels for lowest construction heights, advantageously in case of connection of a shower receptor.

Sololift2 D-2 is suitable for confined space conditions in built-in cabinets or also below shower receptors or pedestals.

The pumping of liquids containing other material may cause faults and limit the scope of our guarantee.

The compact lifting station is equipped with

- Cable with or without plug (see technical data)
- Discharge hose connector with several adaptors for pipes with Ø22-36mm

-Integrated non return valve

- Dry and high performance motor unit incl. thermal protection, pressure switch and controller
- Flexible connectors for inlet (adjustable in height) of pipes Ø36 or 40
- Manual anti clogging function and separate drain connection for service
- Venting valve with overflow protection
- Uplift fixation clips

Design according to EN12050-2 and production inspection by external institute with unique features focused on quick installation, long lasting operation and easy clean service.

**Liquid:**

Maximum liquid temperature: 50 °C

Density: 998.2 kg/m<sup>3</sup>

**Technical:**

Approvals on nameplate: CE,TR,VDEEMV,VDE,MORO

Curve tolerance: ISO9906:2012 3B

**Materials:**

Tank: Plastic

**Installation:**



Company name:

Created by:

Phone:

Date:

03/03/2020

Qty.	Description
	Pump inlet: 36/40/50
	Pump outlet: 22/32
	Number of leads: 3X0,75MM2
	<b>Electrical data:</b>
	Power input - P1: 280 W
	Mains frequency: 50 Hz
	Rated voltage: 1 x 220-240 V
	Rated current: 1.3 A
	Cos phi - power factor: 0.95
	Rated speed: 2800 rpm
	Enclosure class (IEC 34-5): IP44
	Insulation class (IEC 85): F
	Length of cable: 1.2 m
	Cable type: H05VV-F-3G
	Type of cable plug: without
	<b>Others:</b>
	Net weight: 4.56 kg
	Gross weight: 6.25 kg
	Country of origin: RS
	Custom tariff no.: 84137021

**97775333 SOLOLIFT2 D-2 50 Hz**

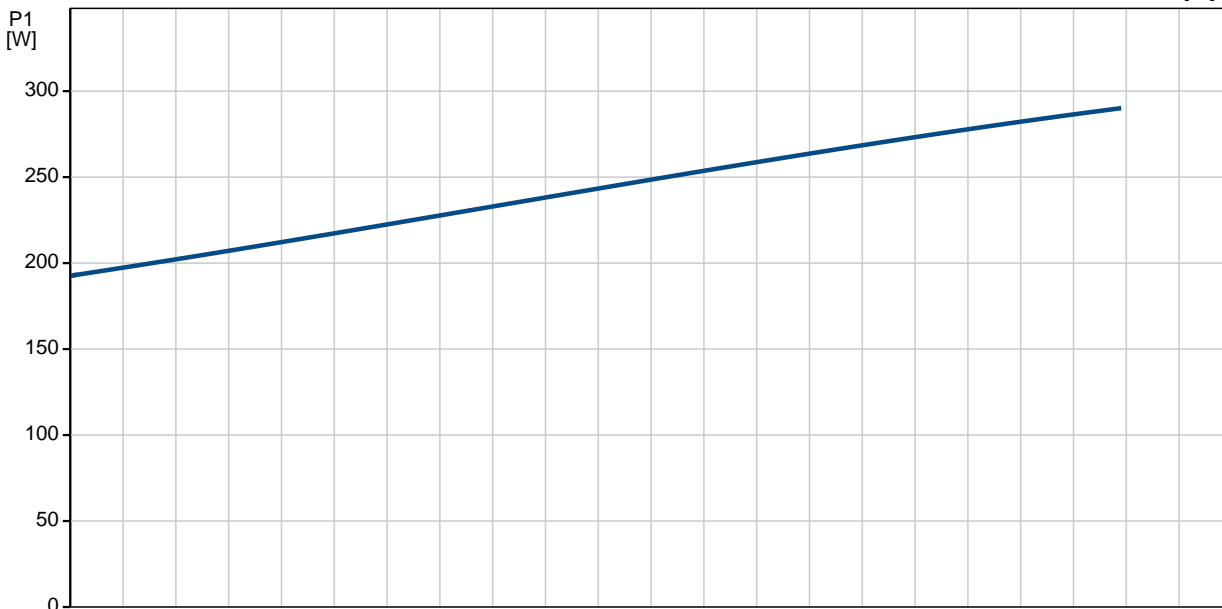
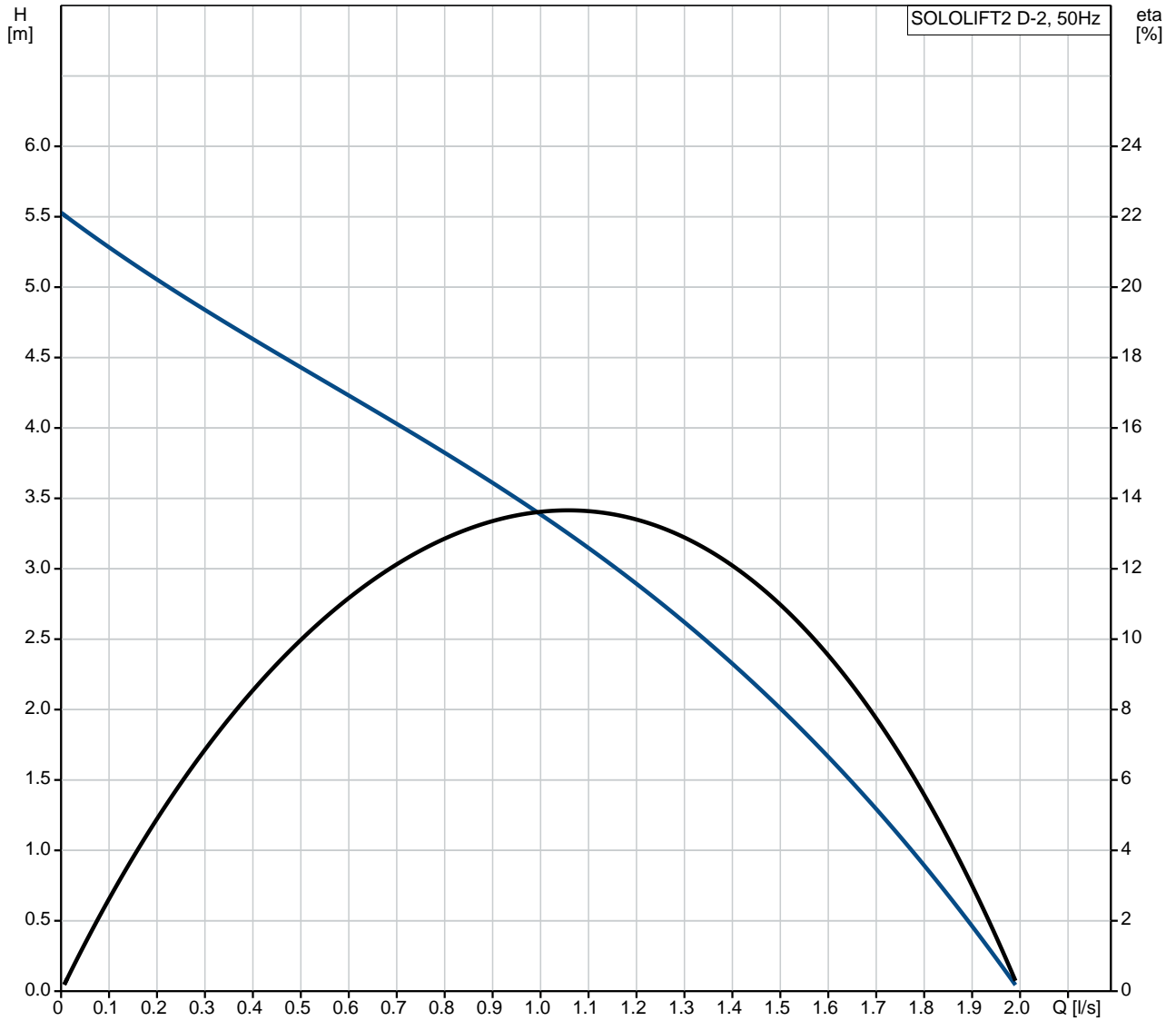

Description	Value
<b>General information:</b>	
Product name:	SOLOLIFT2 D-2
Product No:	97775333
EAN number:	5710624187425
	5710624187425
<b>Technical:</b>	
Head max:	5.5 m
Approvals on nameplate:	CE,TR,VDEEMV,VDE,MORO
Curve tolerance:	ISO9906:2012 3B
<b>Materials:</b>	
Tank:	Plastic
<b>Installation:</b>	
Pump inlet:	36/40/50
Pump outlet:	22/32
Number of leads:	3X0,75MM2
<b>Liquid:</b>	
Maximum liquid temperature:	50 °C
Density:	998.2 kg/m <sup>3</sup>
<b>Electrical data:</b>	
Power input - P1:	280 W
Mains frequency:	50 Hz
Rated voltage:	1 x 220-240 V
Rated current:	1.3 A
Cos phi - power factor:	0.95
Rated speed:	2800 rpm
Enclosure class (IEC 34-5):	IP44
Insulation class (IEC 85):	F
Thermal protec:	THERMIK S06-160-05
Length of cable:	1.2 m
Cable type:	H05VV-F-3G
Type of cable plug:	without
<b>Others:</b>	
Net weight:	4.56 kg
Gross weight:	6.25 kg
Product range:	International
Country of origin:	RS
Custom tariff no.:	84137021

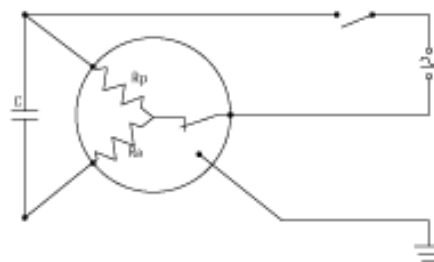
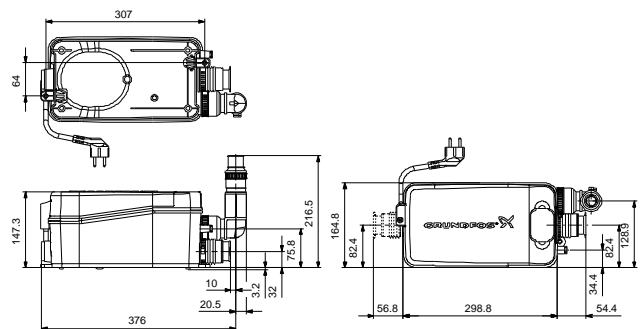
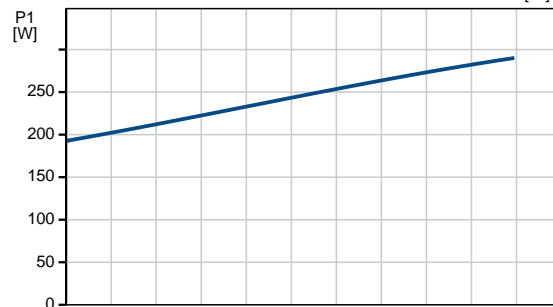
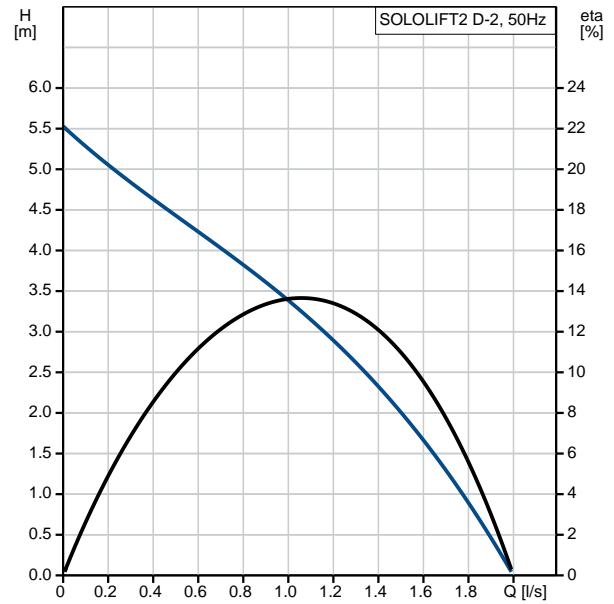

## 97775333 SOLOLIFT2 D-2 50 Hz

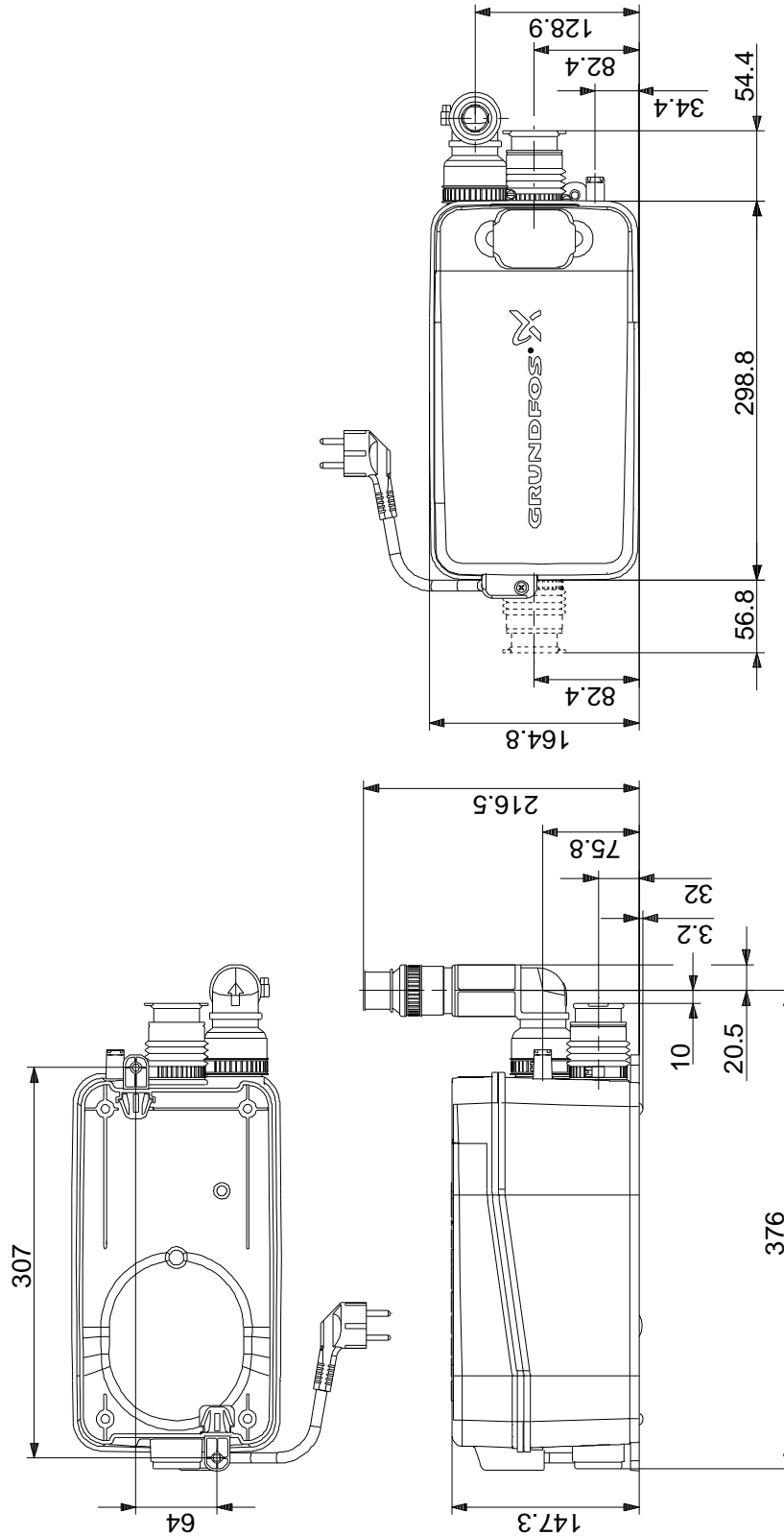

Note! All units are in [mm] unless others are stated.  
Disclaimer: This simplified dimensional drawing does not show all details.