

Qty.	Description										
1	<p><b>DDA 30-4</b>            Product No.: <a href="#">97722345</a>            DDA 30-4 FCM-PV/E/C-F-32U2U2FG</p> <p>The SMART Digital DDA is a compact positive displacement, diaphragm dosing pump with variable-speed drive (stepper motor) and intelligent control electronics with minimum energy consumption. The SMART Digital Dosing series operates at full stroke length to ensure optimum accuracy, priming and suction, even for high-viscosity or degassing liquids. The duration of each discharge stroke varies according to the capacity set, resulting in optimum smooth and continuous discharge flow.</p> <p>The click-stop mounting plate allows installation in three different positions without using any additional accessories. The control cube can be turned easily into front, left or right position. The click wheel and the multi-coloured backlit graphical, plain-text LC display make commissioning and operation intuitive. The control elements are protected by a transparent cover.</p> <p>The sensor-based FlowControl (FC) system detects malfunctions directly in the dosing head and displays them in plain text in the alarm menu, e.g. air bubbles, line burst, overpressure. The integrated flow measurement function (only FCM) measures the actual flow and makes additional monitoring and control equipment redundant (accuracy of <math>\pm 1,5\%</math> of set value in case of trouble-free process). The measured flow is displayed and can be integrated in the process control, e.g. SCADA. Furthermore, the AutoFlowAdapt function (only FCM) automatically adjusts the pump speed according to the process conditions to maintain target flow even at e.g. varying backpressure or air bubbles foaming (degassing drive strategy).</p> <p>The dosing head is composed of:</p> <ul style="list-style-type: none"> <li>- Long lifetime and universal, chemically resistant full-PTFE diaphragm.</li> <li>- Double ball valves for highest dosing accuracy.</li> <li>- Deaeration valve for easy start-up.</li> <li>- Pressure sensor.</li> </ul> <p>Operation modes:</p> <ul style="list-style-type: none"> <li>- Manual dosing in ml/h, l/h or gph.</li> <li>- Pulse control in ml/pulse (incl. memory function).</li> <li>- Analog control 0/4-20 mA (scalable).</li> <li>- Pulse-based batch function in ml, l or gal.</li> <li>- Timer-based batch function (Dosing timer, cycle or week).</li> <li>- Fieldbus control (Genibus prepared for ProfibusDP E-box).</li> </ul> <p>Other features:</p> <ul style="list-style-type: none"> <li>- Auto deaeration during pump standby to avoid breakdowns due to air-locking.</li> <li>- Two SlowMode steps (anti-cavitation), 50 % (maximum flow: 15 l/h) and 25 % (maximum flow: 7.5 l/h), e.g. for high-viscosity or degassing liquids.</li> <li>- Service information display to show when service and which wear-part order number is required.</li> <li>- Two-step key lock function to protect the pump against unauthorised access.</li> <li>- Additional display function to provide further information, e.g. the actual mA input signal.</li> <li>- Counter for total dosed volume (resettable), operating hours, etc.</li> <li>- Save and load customised settings as well as reload of factory settings.</li> </ul> <p>Signal inputs/outputs:</p> <ul style="list-style-type: none"> <li>- Input for pulse, analog 0/4-20mA, external stop.</li> <li>- Input for low-level and empty-tank signal.</li> <li>- Two potential-free output relays for max. 30 V AC/DC (configurable, e.g. alarm, stroke signal, pump dosing, timer etc.)</li> <li>- Output analog 0/4-20mA.</li> <li>- Fieldbus communication interface (GeniBus, also for additional Profibus DP E-box to retrofit).</li> </ul> <p><b>Technical:</b></p> <table border="0"> <tr> <td>Type key:</td> <td>DDA 30-4 FCM-PV/E/C-F-32U2U2FG</td> </tr> <tr> <td>Max. Flow:</td> <td>30 l/h</td> </tr> <tr> <td>Max. flow in slow mode 50%:</td> <td>15 l/h</td> </tr> <tr> <td>Max. flow in slow mode 25%:</td> <td>7.5 l/h</td> </tr> <tr> <td>Min flow:</td> <td>30.0 ml/h</td> </tr> </table>	Type key:	DDA 30-4 FCM-PV/E/C-F-32U2U2FG	Max. Flow:	30 l/h	Max. flow in slow mode 50%:	15 l/h	Max. flow in slow mode 25%:	7.5 l/h	Min flow:	30.0 ml/h
Type key:	DDA 30-4 FCM-PV/E/C-F-32U2U2FG										
Max. Flow:	30 l/h										
Max. flow in slow mode 50%:	15 l/h										
Max. flow in slow mode 25%:	7.5 l/h										
Min flow:	30.0 ml/h										

Qty.	Description
	Turn-down ratio: 1:1000 Approvals on nameplate: CE,CSA-US,NSF61,EAC,RCM Valve type: Spring-Loaded (HV-version) Maximum viscosity at 100 %: 200 mPas Maximum viscosity in slow mode 50 %: 600 mPas Maximum viscosity in slow mode 25 %: 1500 mPas Accuracy of repeatability: 1 %  <b>Materials:</b> Dosing head: PVDF (Polyvinylidene fluoride) Valve ball: Ceramic Gasket: EPDM  <b>Installation:</b> Range of ambient temperature: 0 .. 45 °C Maximum operating pressure: 4 bar Installation set: NO Installation type: No installation set Pump inlet: 4/6, 6/9, 6/12, 9/12 mm Pump outlet: 4/6, 6/9, 6/12, 9/12 mm Max. Suction lift during operation: 6 m Max. Suction lift during priming: 2 m  <b>Liquid:</b> Pumped liquid: Water Liquid temperature range: -10 .. 45 °C Selected liquid temperature: 20 °C Density: 998.2 kg/m <sup>3</sup>  <b>Electrical data:</b> Maximum power input - P1: 24 W Mains frequency: 50 / 60 Hz Rated voltage: 1 x 100-240 V Enclosure class (IEC 34-5): IP65 / NEMA 4X Length of cable: 1.5 m Type of cable plug: EU Inrush current: 25A at 230V for 2ms  <b>Controls:</b> Control variant: FCM Level control: YES Analog input: 0/4-20 MA Pulse control: YES Ext. Stop input: YES Analog output: 0/4-20 MA Output relays: 2 Bus communication: YES  <b>Others:</b> Net weight: 3 kg Gross weight: 4 kg Color: RED



Company name:

Created by:

Phone:

Date:

04/02/2020

## 97722345 DDA 30-4

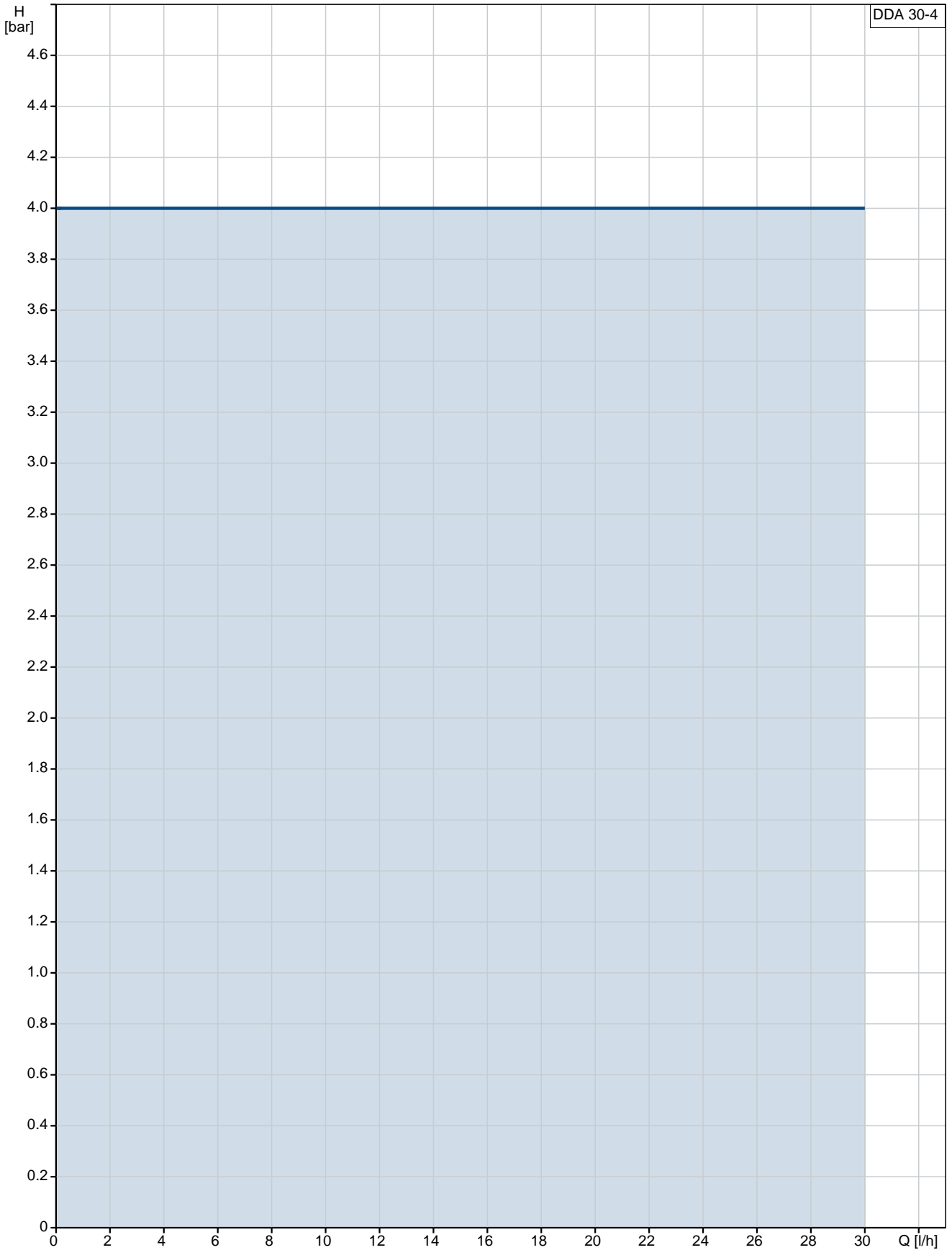

Description	Value
<b>General information:</b>	
Product name:	DDA 30-4
Product No:	97722345
EAN number:	5710622724875
	5710622724875
<b>Technical:</b>	
Type key:	DDA 30-4 FCM-PV/E/C-F-32U2U2FG
Max. Flow:	30 l/h
Max. flow in slow mode 50%:	15 l/h
Max. flow in slow mode 25%:	7.5 l/h
Min flow:	30.0 ml/h
Turn-down ratio:	1:1000
Approvals on nameplate:	CE, CSA-US, NSF61, EAC, RCM
Valve type:	Spring-Loaded (HV-version)
Maximum viscosity at 100 %:	200 mPas
Maximum viscosity in slow mode 50 %:	600 mPas
Maximum viscosity in slow mode 25 %:	1500 mPas
Accuracy of repeatability:	1 %
<b>Materials:</b>	
Dosing head:	PVDF (Polyvinylidene fluoride)
Valve ball:	Ceramic
Gasket:	EPDM
<b>Installation:</b>	
Range of ambient temperature:	0 .. 45 °C
Maximum operating pressure:	4 bar
Installation set:	NO
Installation type:	No installation set
Pump inlet:	4/6, 6/9, 6/12, 9/12 mm
Pump outlet:	4/6, 6/9, 6/12, 9/12 mm
Max. Suction lift during operation:	6 m
Max. Suction lift during priming:	2 m
<b>Liquid:</b>	
Pumped liquid:	Water
Liquid temperature range:	-10 .. 45 °C
Selected liquid temperature:	20 °C
Density:	998.2 kg/m <sup>3</sup>
<b>Electrical data:</b>	
Maximum power input - P1:	24 W
Mains frequency:	50 / 60 Hz
Rated voltage:	1 x 100-240 V
Enclosure class (IEC 34-5):	IP65 / NEMA 4X
Length of cable:	1.5 m
Type of cable plug:	EU
Inrush current:	25A at 230V for 2ms
<b>Controls:</b>	
Control variant:	FCM
Control panel:	FRONT-MOUNTED
Level control:	YES
Analog input:	0/4-20 MA
Pulse control:	YES
Ext. Stop input:	YES
Analog output:	0/4-20 MA
Output relays:	2
Bus communication:	YES
<b>Others:</b>	

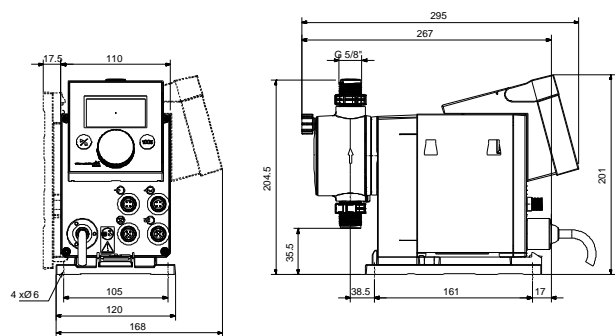
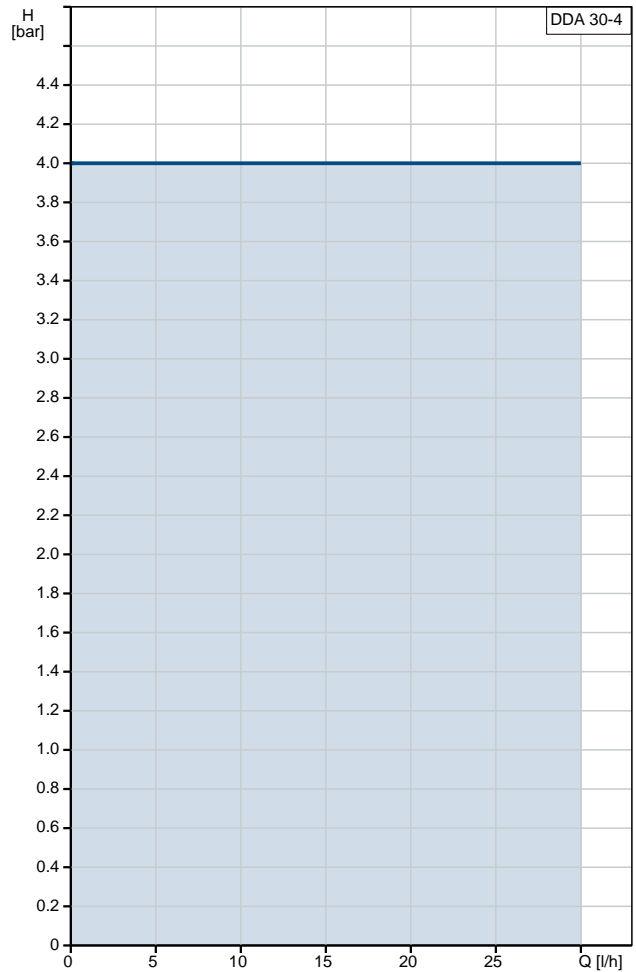



Company name:

Created by:

Phone:

Date: 04/02/2020

Description	Value
Net weight:	3 kg
Gross weight:	4 kg
Color:	RED

## 97722345 DDA 30-4

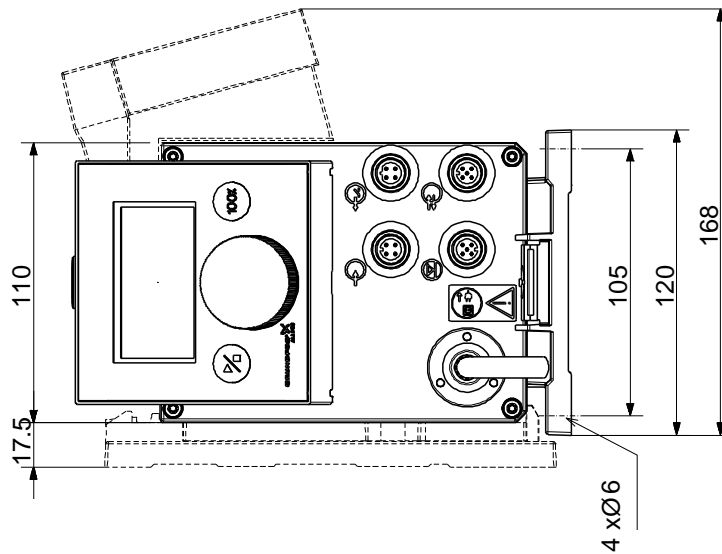
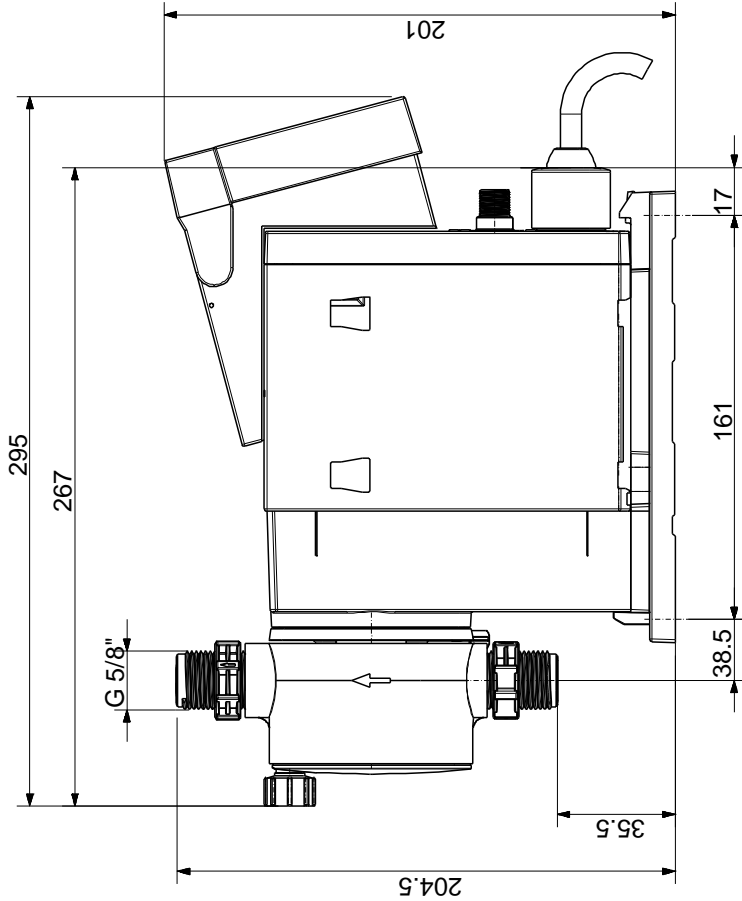

Note! All units are in [mm] unless others are stated.  
Disclaimer: This simplified dimensional drawing does not show all details.