

Qty. Description

1 DDA 12-10



Note! Product picture may differ from actual product

Product No.: [97722059](#)

DDA 12-10 AR-PVC/T/C-F-32I002F

The SMART Digital DDA is a compact positive displacement, diaphragm dosing pump with variable-speed drive (stepper motor) and intelligent control electronics with minimum energy consumption. The SMART Digital Dosing series operates at full stroke length to ensure optimum accuracy, priming and suction, even for high-viscosity or degassing liquids. The duration of each discharge stroke varies according to the capacity set, resulting in optimum smooth and continuous discharge flow.

The click-stop mounting plate allows installation in three different positions without using any additional accessories. The control cube can be turned easily into front, left or right position. The click wheel and the multi-coloured backlit graphical, plain-text LC display make commissioning and operation intuitive. The control elements are protected by a transparent cover.

The dosing head is composed of:

- Long lifetime and universal, chemically resistant full-PTFE diaphragm.
- Double ball valves for highest dosing accuracy.
- Deaeration valve for easy start-up.

Operation modes:

- Manual dosing in ml/h, l/h or gph.
- Pulse control in ml/pulse (incl. memory function).
- Analog control 0/4-20 mA (scalable).
- Pulse-based batch function in ml, l or gal.
- Timer-based batch function (Dosing timer, cycle or week).
- Fieldbus control (Genibus prepared for ProfibusDP E-box).

Other features:

- Auto deaeration during pump standby to avoid breakdowns due to air-locking.
- Two SlowMode steps (anti-cavitation), 50 % (maximum flow: 6 l/h) and 25 % (maximum flow: 3 l/h), e.g. for high-viscosity or degassing liquids.
- Service information display to show when service and which wear-part order number is required.
- Two-step key lock function to protect the pump against unauthorised access.
- Additional display function to provide further information, e.g. the actual mA input signal.
- Counter for total dosed volume (resettable), operating hours, etc.
- Save and load customised settings as well as reload of factory settings.

Signal inputs/outputs:

- Input for pulse, analog 0/4-20mA, external stop.
- Input for low-level and empty-tank signal.
- Two potential-free output relays for max. 30 V AC/DC (configurable, e.g. alarm, stroke signal, pump dosing, timer etc.)
- Output analog 0/4-20mA.
- Fieldbus communication interface (GeniBus, also for additional Profibus DP E-box to retrofit).

Installation set includes:

- 2 pump connections (Hose 9/12 mm 6).

Qty.	Description
	<ul style="list-style-type: none"> - Foot valve (without level switch). - Injection unit. - 6 m PE discharge hose. - 2 m PVC suction hose. - 2 m PVC deaeration hose (4/6 mm). <p>Technical:</p> <p>Type key: DDA 12-10 AR-PVC/T/C-F-32I002F</p> <p>Max. Flow: 12 l/h</p> <p>Max. flow in slow mode 50%: 6 l/h</p> <p>Max. flow in slow mode 25%: 3 l/h</p> <p>Min flow: 12.0 ml/h</p> <p>Turn-down ratio: 1:1000</p> <p>Approvals on nameplate: CE, CSA-US, NSF61, EAC, RCM</p> <p>Valve type: Spring-Loaded (HV-version)</p> <p>Maximum viscosity at 100 %: 500 mPas</p> <p>Maximum viscosity in slow mode 50 %: 1300 mPas</p> <p>Maximum viscosity in slow mode 25 %: 2500 mPas</p> <p>Accuracy of repeatability: 1 %</p> <p>Materials:</p> <p>Dosing head: PVC (Polyvinyl chloride)</p> <p>Valve ball: Ceramic</p> <p>Gasket: PTFE</p> <p>Installation:</p> <p>Range of ambient temperature: 0 .. 45 °C</p> <p>Maximum operating pressure: 10 bar</p> <p>Installation set: YES</p> <p>Installation type: 9/12 mm up to 60 l/h, 13 bar</p> <p>Pump inlet: Hose 9/12 mm 6</p> <p>Pump outlet: Hose 9/12 mm 6</p> <p>Max. Suction lift during operation: 6 m</p> <p>Max. Suction lift during priming: 3 m</p> <p>Liquid:</p> <p>Pumped liquid: Water</p> <p>Liquid temperature range: -10 .. 45 °C</p> <p>Selected liquid temperature: 20 °C</p> <p>Density: 998.2 kg/m³</p> <p>Electrical data:</p> <p>Maximum power input - P1: 24 W</p> <p>Mains frequency: 50 / 60 Hz</p> <p>Rated voltage: 1 x 100-240 V</p> <p>Enclosure class (IEC 34-5): IP65 / NEMA 4X</p> <p>Length of cable: 1.5 m</p> <p>Type of cable plug: EU</p> <p>Inrush current: 25A at 230V for 2ms</p> <p>Controls:</p> <p>Control variant: AR</p> <p>Level control: YES</p> <p>Analog input: 0/4-20 MA</p> <p>Pulse control: YES</p> <p>Ext. Stop input: YES</p> <p>Analog output: 0/4-20 MA</p> <p>Output relays: 2</p>



Company name:

Created by:

Phone:

Date:

25/02/2020

Qty.	Description
	<p data-bbox="199 338 619 369">Bus communication: YES</p> <p data-bbox="199 400 293 432">Others:</p> <p data-bbox="199 432 619 463">Net weight: 2 kg</p> <p data-bbox="199 463 619 495">Gross weight: 3 kg</p> <p data-bbox="199 495 619 526">Color: RED</p>



Company name:

Created by:

Phone:

Date:

25/02/2020

97722059 DDA 12-10

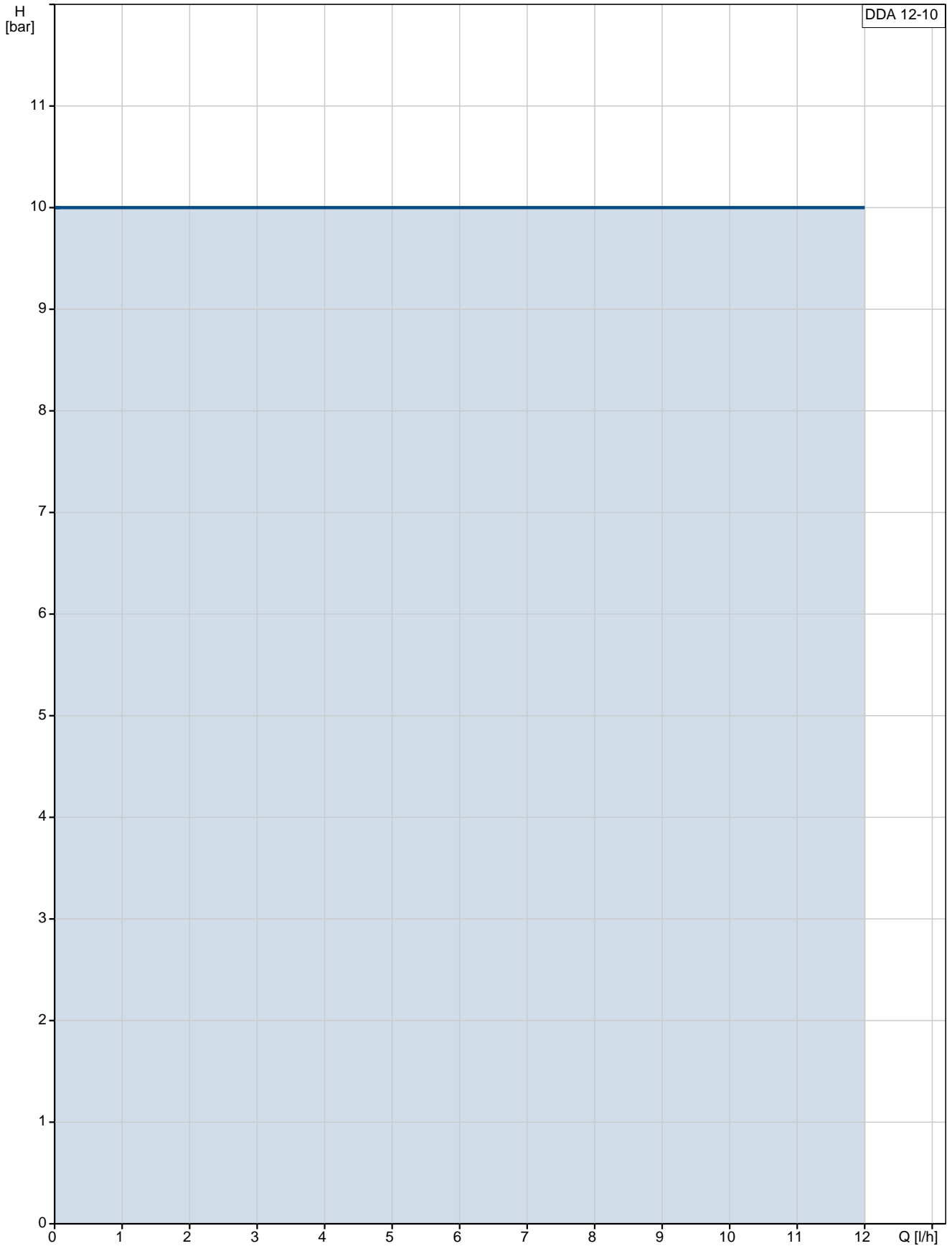

Description	Value
General information:	
Product name:	DDA 12-10
Product No:	97722059
EAN number:	5710622722017
	5710622722017
Technical:	
Type key:	DDA 12-10 AR-PVC/T/C-F-32I002F
Max. Flow:	12 l/h
Max. flow in slow mode 50%:	6 l/h
Max. flow in slow mode 25%:	3 l/h
Min flow:	12.0 ml/h
Turn-down ratio:	1:1000
Approvals on nameplate:	CE,CSA-US,NSF61,EAC,RCM
Valve type:	Spring-Loaded (HV-version)
Maximum viscosity at 100 %:	500 mPas
Maximum viscosity in slow mode 50 %:	1300 mPas
Maximum viscosity in slow mode 25 %:	2500 mPas
Accuracy of repeatability:	1 %
Materials:	
Dosing head:	PVC (Polyvinyl chloride)
Valve ball:	Ceramic
Gasket:	PTFE
Installation:	
Range of ambient temperature:	0 .. 45 °C
Maximum operating pressure:	10 bar
Installation set:	YES
Installation type:	9/12 mm up to 60 l/h, 13 bar
Pump inlet:	Hose 9/12 mm 6
Pump outlet:	Hose 9/12 mm 6
Max. Suction lift during operation:	6 m
Max. Suction lift during priming:	3 m
Liquid:	
Pumped liquid:	Water
Liquid temperature range:	-10 .. 45 °C
Selected liquid temperature:	20 °C
Density:	998.2 kg/m ³
Electrical data:	
Maximum power input - P1:	24 W
Mains frequency:	50 / 60 Hz
Rated voltage:	1 x 100-240 V
Enclosure class (IEC 34-5):	IP65 / NEMA 4X
Length of cable:	1.5 m
Type of cable plug:	EU
Inrush current:	25A at 230V for 2ms
Controls:	
Control variant:	AR
Control panel:	FRONT-MOUNTED
Level control:	YES
Analog input:	0/4-20 MA
Pulse control:	YES
Ext. Stop input:	YES
Analog output:	0/4-20 MA
Output relays:	2
Bus communication:	YES
Others:	

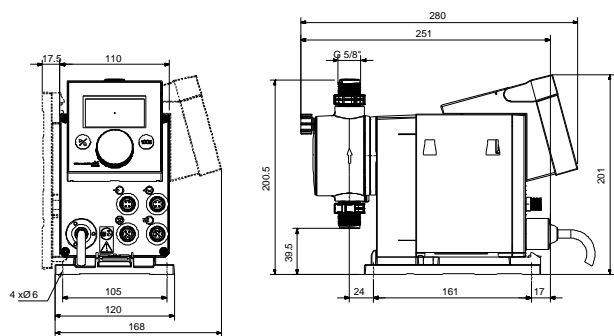
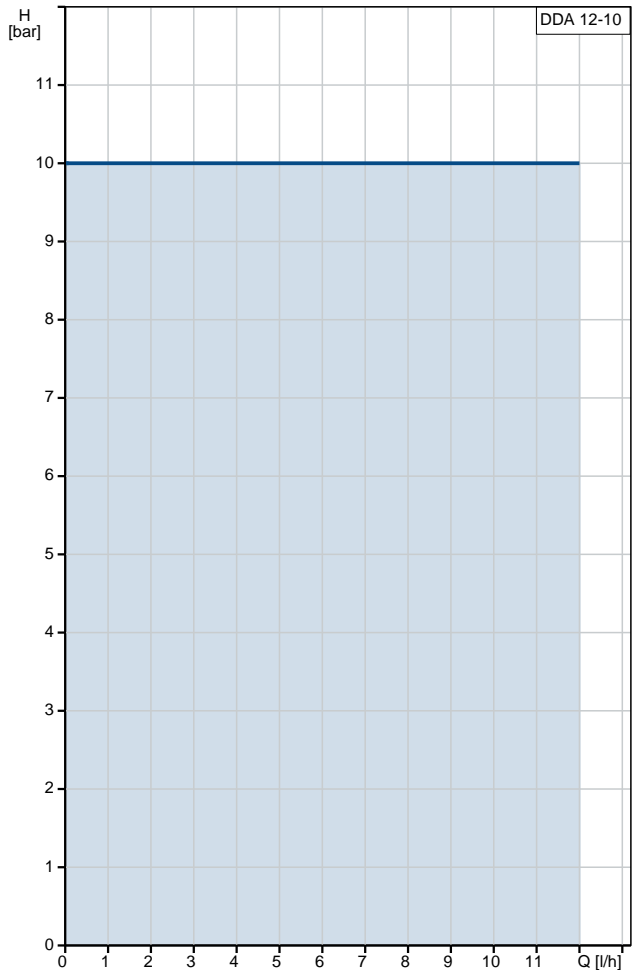



Company name:

Created by:

Phone:

Date:

25/02/2020

Description	Value
Net weight:	2 kg
Gross weight:	3 kg
Color:	RED

97722059 DDA 12-10

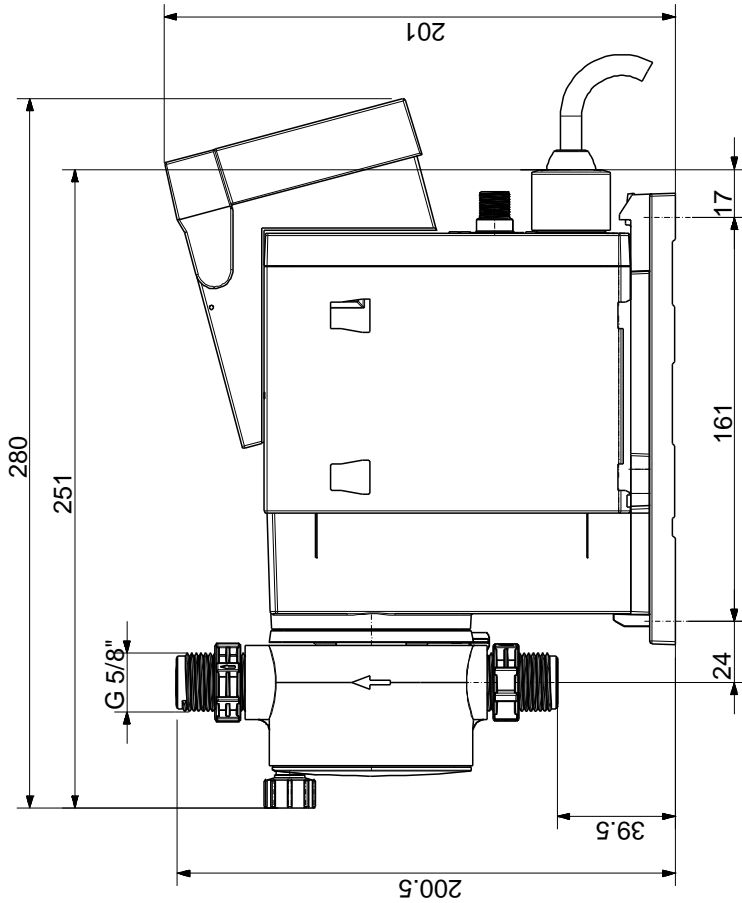

Note! All units are in [mm] unless others are stated.
Disclaimer: This simplified dimensional drawing does not show all details.