

**Qty. Description**

1 **SLV.65.65.11.E.EX.2.50B**



**Note! Product picture may differ from actual product**

Product No.: [96878481](#)

Non-self-priming, single-stage, centrifugal pump designed for handling wastewater, process water and unscreened raw sewage.

The pump is designed for intermittent and continuous operations in submerged installation. The efficient SuperVortex impeller provides passage of long fibres and solids up to 2 9/16 in and is suitable for wastewater with a dry matter content of up to 5 %. A unique stainless-steel clamp assembling system enables quick and easy disassembly of the pump from the motor unit for service and inspection. No special tools are required. Pipework connection is via a DIN flange.

The pump is explosion-proof.

### Further product details

The pump is suitable for both temporary and permanent installation either as free-standing on ring stand or on an auto-coupling system.

### Pump

The pump housing, motor top and impeller are made of cast iron (EN-GJL-250).

All surfaces of the cast iron parts are protected with cathodolysis coating. The surface of the cast iron pump parts is afterwards painted with environmental friendly powder coating (type NCS 9000N (black), gloss code 30, thickness 100 µm) which ensures high impact and corrosion protection. The final pump is assembled from already painted parts which ensures that no rust or scale can be formed in grooves between parts, etc.

The SuperVortex impeller is a symmetrical multivane winglet impeller. The design ensures a flow entirely outside the impeller providing limited contact between the impeller and the pumped liquid. This ensures that long fibres, rags and more passes freely through the pump without getting caught and without causing clogging or jamming.



The shaft seal consists of two mechanical seals that ensure a reliable sealing between the pumped liquid and motor. The shaft seals are incorporated in a single-unit cartridge shaft seal system that is easy to replace in the field without use of special tools.

The combination of the primary and secondary seals in a cartridge shaft seal system results in a shorter assembly length compared to conventional shaft seals.

**Qty. Description**

- Primary seal: Silicon carbide/silicon carbide (SiC/SiC)
- Secondary seal: Carbon/Ceramics

The shaft seal is bidirectional, meaning it operates correctly in case of backflow through the pump.



The pump is approved according to CE 0344. The pump is approved for installation in explosive atmospheres and holds the following examination certificate:

- ATEX (EU): KEMA08ATEX0125X
- IECEX: IECEX KEM08.0039X

The certificate has been issued according to the ATEX directive (94/9/EC).

For applications involving a risk of explosion, or where otherwise required, the pump is approved with the following explosion protection classifications.

Mains-driven pump, without sensor:

II2 G Ex cd IIB T3, T4 Gb

Mains-driven pump, with sensor:

II2 G Ex cd mb IIB T3, T4 Gb

Frequency converter pump, without sensor:

II2 G Ex cd IIB T3, T4 Gb

Frequency converter pump, with sensor:

II2 G Ex cd mb IIB T3, T4 Gb

Note: Explosion-proof pumps must always be fully submerged.

**Motor**

The motor is a watertight, totally encapsulated motor supplied with a 33 ft power cable. The stainless steel plug is fastened with a union nut. This nut and the O-rings provide sealing against ingress of the liquid.

The plug is polyurethane-embedded, ensuring a watertight and durable seal around the leads of the cable. This prevents the ingress of water into the motor through the cable in case of cable breakage or adverse handling in connection with installation or service.

A compact motor construction with a short shaft reduces vibrations, resulting in an increased efficiency and lifetime of the shaft seal and ball bearings.

The motor features built-in thermal protection to protect the motor against overheating and ensure the reliability.

The pump is designed for speed-controlled operation to keep the energy consumption at a minimum. To avoid the risk of sedimentation in the pipes, we recommend that you operate the speed-controlled pump within a speed range of 30 % to 100 % and at a flow rate above 1 m/s.

**Controls:**

Moisture sensor:	without moisture sensors
Water-in-oil sensor:	without water-in-oil sensor
AUTOADAPT:	YES

**Liquid:**

Pumped liquid:	Any Newtonian liquid
Maximum liquid temperature:	104 °F
Density:	62.29 lb/ft <sup>3</sup>

**Technical:**

Type of impeller:	SUPER VORTEX
Maximum particle size:	2 9/16 in
Primary shaft seal:	SIC/SIC
Secondary shaft seal:	LIPSEAL
Approvals on nameplate:	CE 0344
Curve tolerance:	ISO9906:2012 3B2

**Materials:**

Qty.	Description
	Pump housing: Cast iron EN-JL-1030 Impeller: Cast iron EN-GJS-400-15 Motor: EN-GJL-200 Installation: Maximum ambient temperature: 104 °F Flange standard: DIN Pump outlet: 65 Pressure rating: PN 10 Maximum installation depth: 32.8 ft Frame range: A Electrical data: Power input - P1: 1.6 kW Rated power - P2: 1.5 HP Mains frequency: 50 Hz Rated voltage: 3 x 400-415 V Voltage tolerance: +6/-10 % Max starts per. hour: 30 Rated current: 3.1-3.1 A Rated current at 3/4 load: 2.7 A Rated current at 1/2 load: 2.2 A Starting current: 21 A Rated current at no load: 1.9 A Cos phi - power factor: 0.81 Cos phi - p.f. at 3/4 load: 0.74 Cos phi - p.f. at 1/2 load: 0.63 Rated speed: 2830 rpm Motor efficiency at full load: 67 % Motor efficiency at 3/4 load: 64 % Motor efficiency at 1/2 load: 57 % Number of poles: 2 Start. method: direct-on-line Enclosure class (IEC 34-5): IP68 Insulation class (IEC 85): F Explosion proof: yes Length of cable: 33 ft Cable type: LYNIFLEX Others: Net weight: 116 lb Country of origin: HU Custom tariff no.: 84137021

## 96878481 SLV.65.65.11.E.EX.2.50B 50 Hz

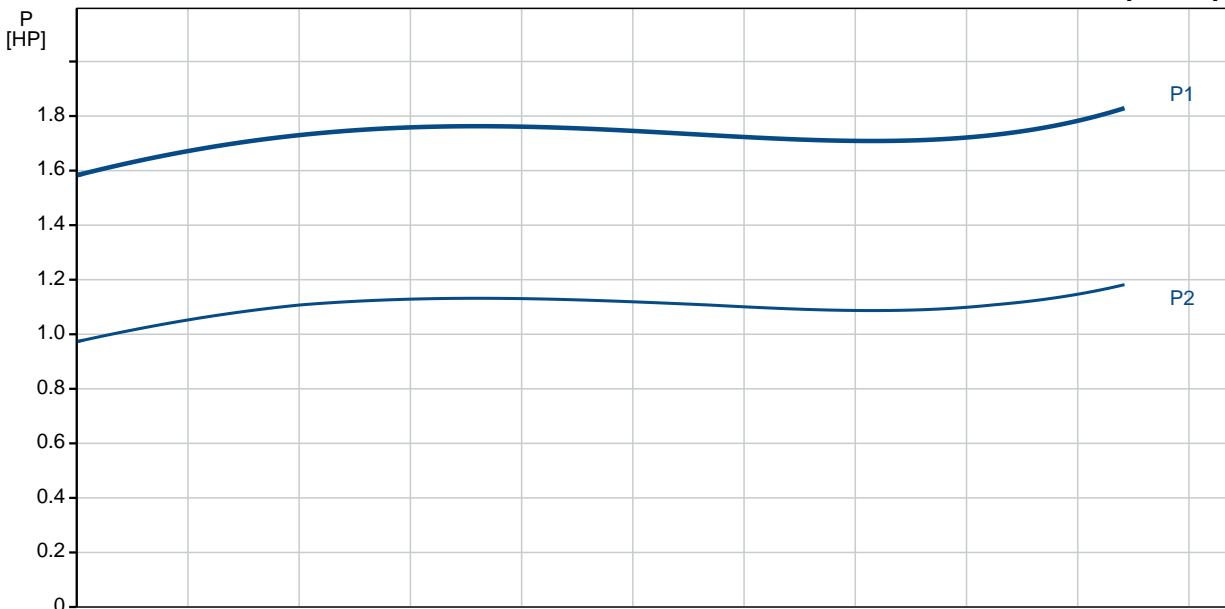
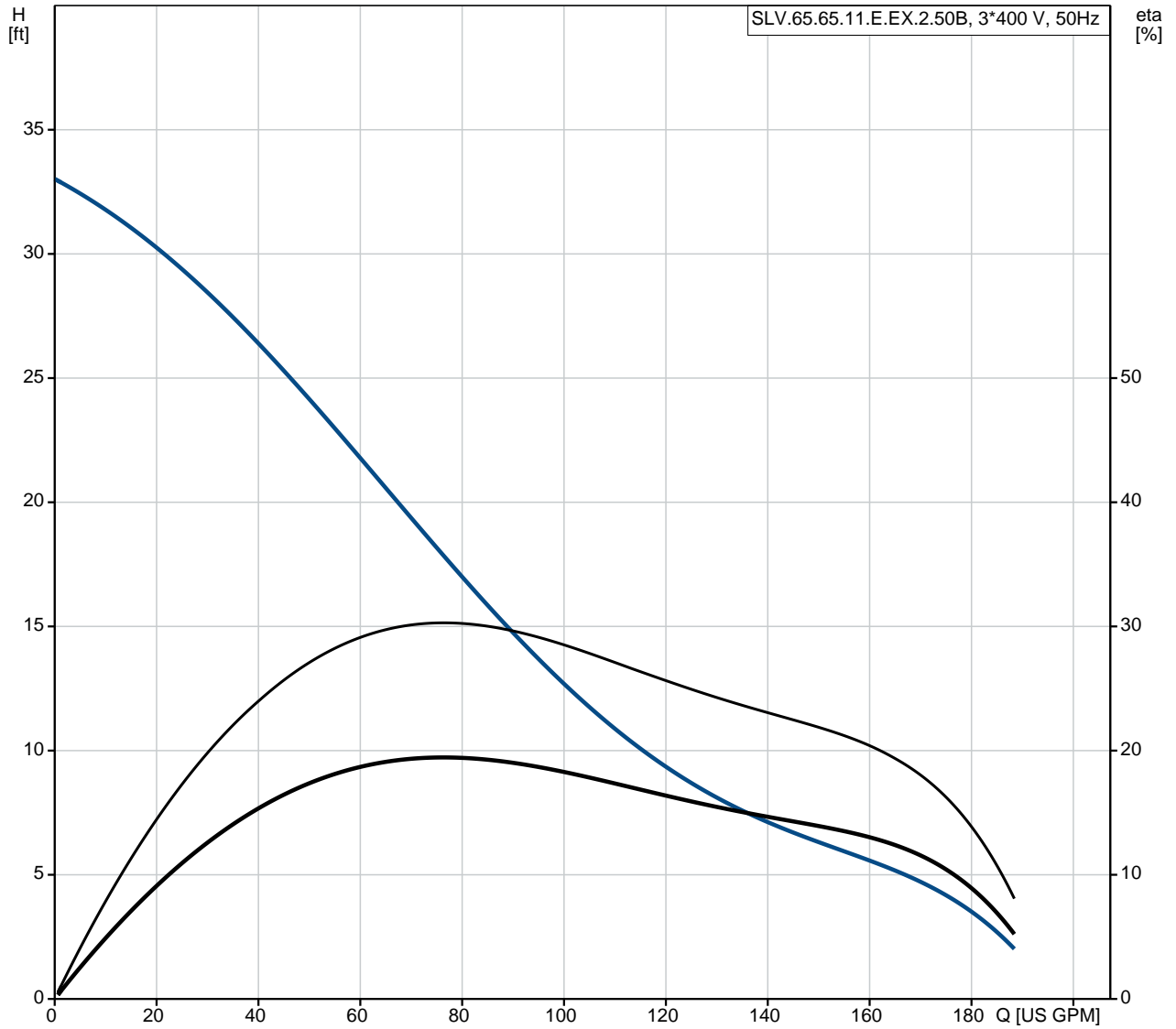

Description	Value
<b>General information:</b>	
Product name:	SLV.65.65.11.E.EX.2.50B
Product No:	96878481
EAN number:	5700312550839
Price:	GBP 2244
<b>Technical:</b>	
Maximum flow:	188 US GPM
Max flow:	188 US GPM
Head max:	31.17 ft
Type of impeller:	SUPER VORTEX
Maximum particle size:	2 9/16 in
Primary shaft seal:	SIC/SIC
Secondary shaft seal:	LIPSEAL
Approvals on nameplate:	CE 0344
Curve tolerance:	ISO9906:2012 3B2
Cooling jacket:	without cooling jacket
<b>Materials:</b>	
Pump housing:	Cast iron
Pump housing:	EN-JL-1030
Impeller:	Cast iron
Impeller:	EN-GJS-400-15
Motor:	EN-GJL-200
<b>Installation:</b>	
Maximum ambient temperature:	104 °F
Flange standard:	DIN
Pump outlet:	65
Pressure rating:	PN 10
Maximum installation depth:	32.8 ft
Inst dry/wet:	SUBMERGED
Installation:	Vertical
Frame range:	A
<b>Liquid:</b>	
Pumped liquid:	Any Newtonian liquid
Maximum liquid temperature:	104 °F
Density:	62.29 lb/ft <sup>3</sup>
<b>Electrical data:</b>	
Power input - P1:	1.6 kW
Rated power - P2:	1.5 HP
Mains frequency:	50 Hz
Rated voltage:	3 x 400-415 V
Voltage tolerance:	+6/-10 %
Max starts per. hour:	30
Rated current:	3.1-3.1 A
Rated current at 3/4 load:	2.7 A
Rated current at 1/2 load:	2.2 A
Starting current:	21 A
Rated current at no load:	1.9 A
Cos phi - power factor:	0.81
Cos phi - p.f. at 3/4 load:	0.74
Cos phi - p.f. at 1/2 load:	0.63
Rated speed:	2830 rpm
Motor efficiency at full load:	67 %
Motor efficiency at 3/4 load:	64 %
Motor efficiency at 1/2 load:	57 %
Number of poles:	2
Start. method:	direct-on-line
Enclosure class (IEC 34-5):	IP68
Insulation class (IEC 85):	F

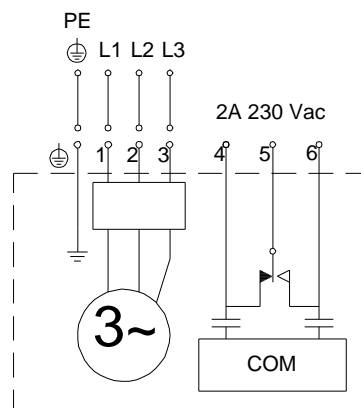
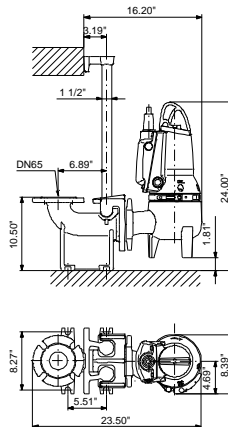
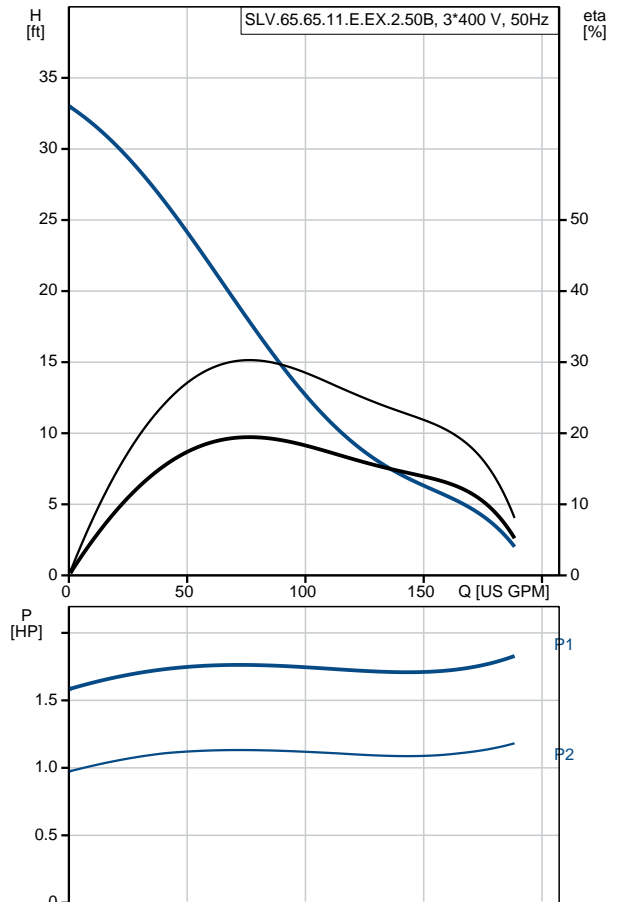



Company name:

Created by:

Phone:

Date:

01/10/2020

Description	Value
Explosion proof:	yes
Motor protec:	THERMAL SWITCH
Length of cable:	33 ft
Cable type:	LYNIFLEX
<b>Controls:</b>	
Control box:	not included
Moisture sensor:	without moisture sensors
Water-in-oil sensor:	without water-in-oil sensor
AUTOADAPT:	YES
<b>Others:</b>	
Net weight:	116 lb
Country of origin:	HU
Custom tariff no.:	84137021

## 96878481 SLV.65.65.11.E.EX.2.50B 50 Hz

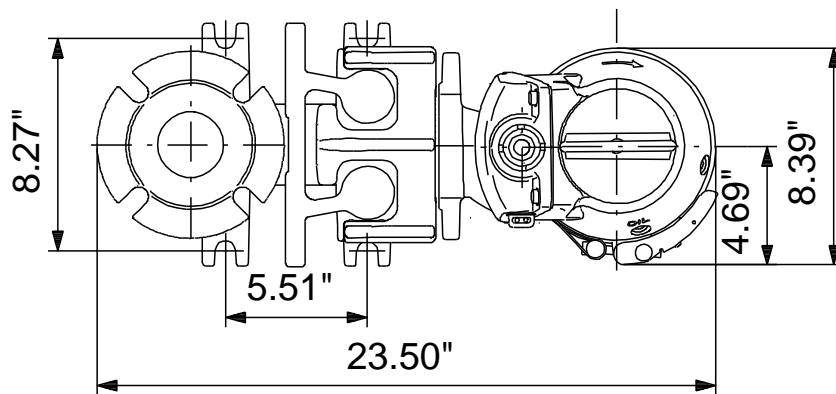
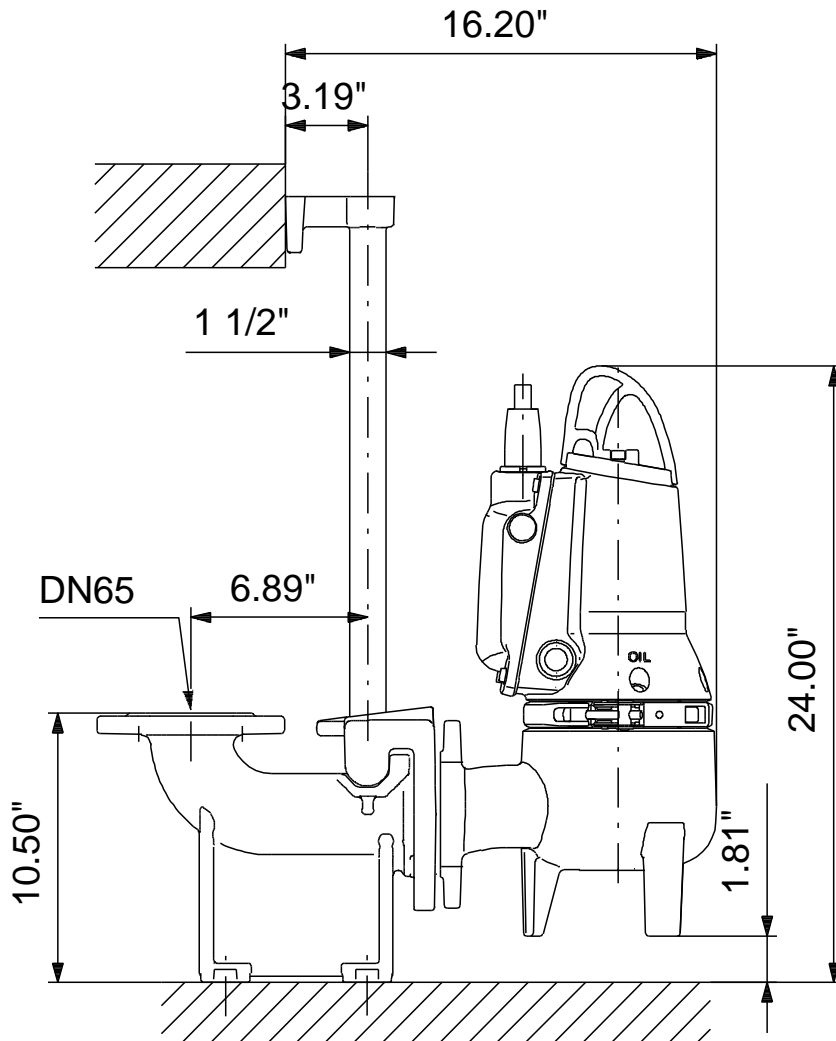

Note! All units are in [in] unless others are stated.  
Disclaimer: This simplified dimensional drawing does not show all details.

## 96878481 SLV.65.65.11.E.EX.2.50B 50 Hz

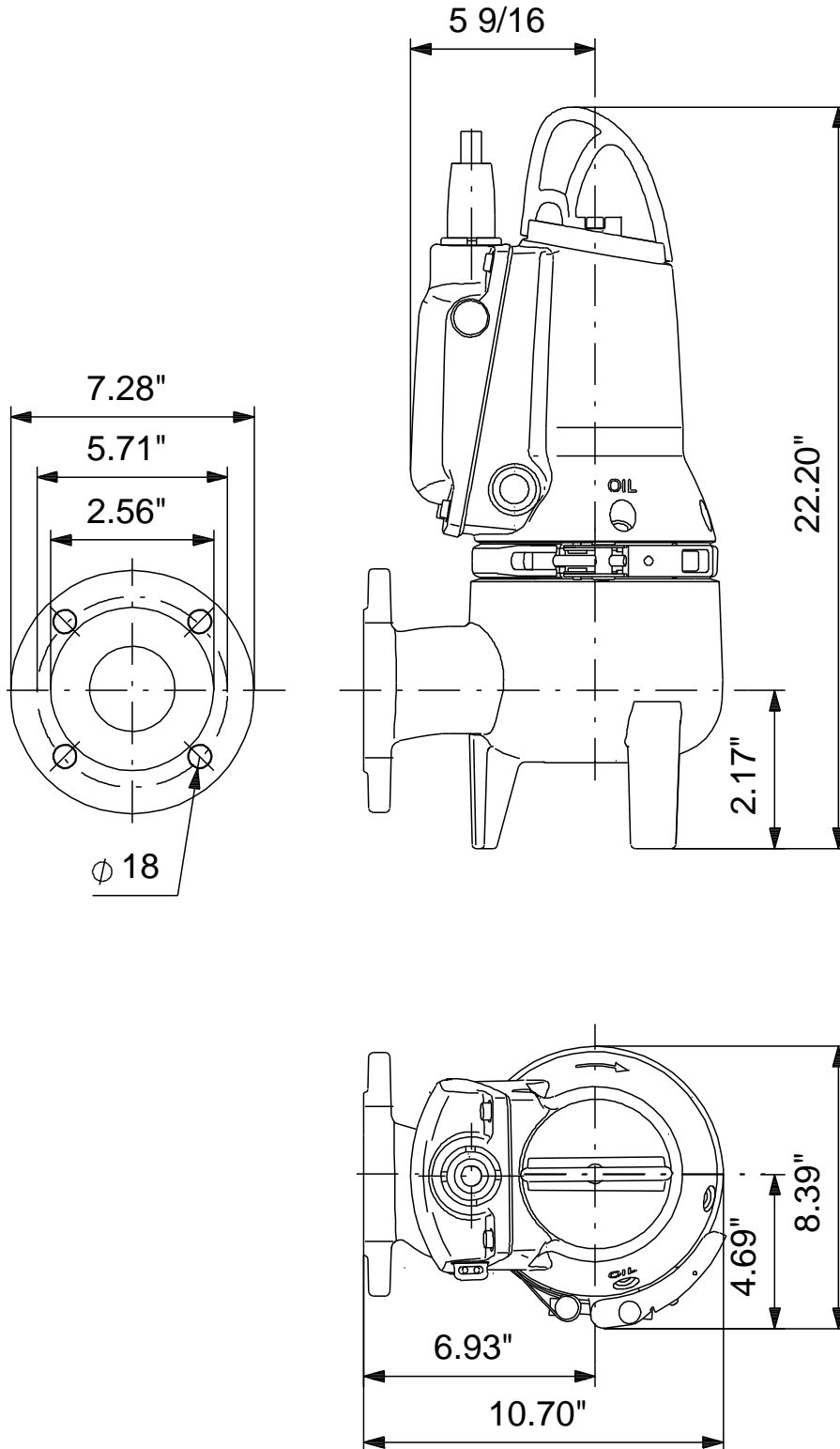

Note! All units are in [in] unless others are stated.  
Disclaimer: This simplified dimensional drawing does not show all details.



**96878481 SLV.65.65.11.E.EX.2.50B 50 Hz**

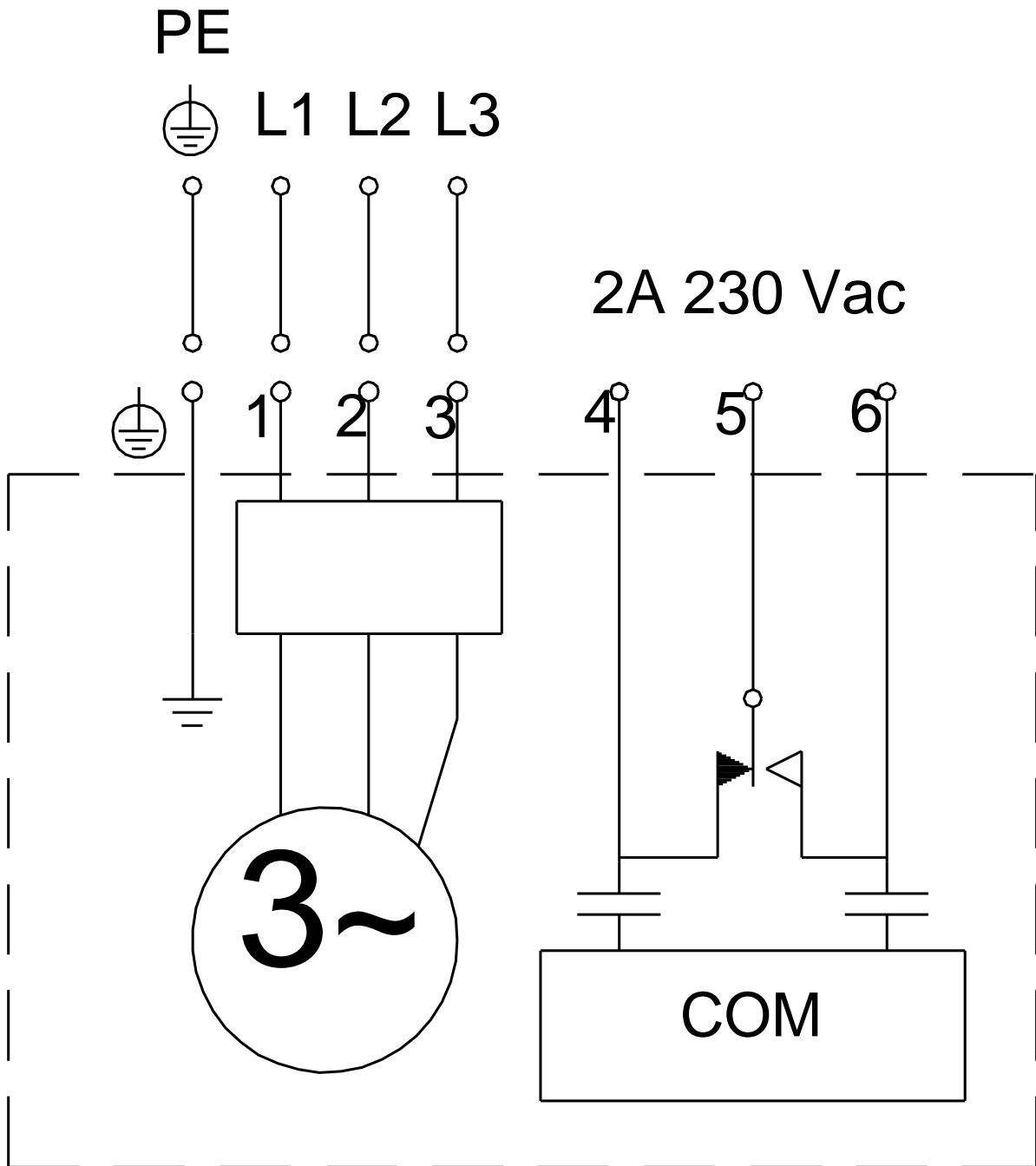

Note! All units are in [in] unless others are stated.