

Qty.	Description
1	<p data-bbox="199 340 518 362">CRN 64-3-1 A-F-H-E-HQQE</p>  <p data-bbox="199 660 470 683">Product No.: 96692772</p> <p data-bbox="199 721 1460 817">Vertical, multistage centrifugal pump with inlet and outlet ports on same the level (inline). Pump materials in contact with the liquid are in high-grade stainless steel. A cartridge shaft seal ensures high reliability, safe handling, and easy access and service. Power transmission is via a rigid split coupling. Pipe connection is via DIN flanges.</p> <p data-bbox="199 862 933 884">The pump is fitted with a 3-phase, fan-cooled asynchronous motor.</p> <p data-bbox="199 922 311 945">Controls:</p> <p data-bbox="199 952 638 974">Frequency converter: NONE</p> <p data-bbox="199 1012 287 1034">Liquid:</p> <p data-bbox="199 1041 638 1064">Pumped liquid: Water</p> <p data-bbox="199 1070 710 1093">Liquid temperature range: -40 .. 120 °C</p> <p data-bbox="199 1099 686 1122">Liquid temperature during operation: 20 °C</p> <p data-bbox="199 1128 702 1151">Density: 998.2 kg/m³</p> <p data-bbox="199 1189 327 1211">Technical:</p> <p data-bbox="199 1218 821 1240">Pump speed on which pump data are based: 2923 rpm</p> <p data-bbox="199 1247 654 1270">Rated flow: 64 m³/h</p> <p data-bbox="199 1276 646 1299">Rated head: 59.8 m</p> <p data-bbox="199 1305 646 1328">Pump orientation: Vertical</p> <p data-bbox="199 1335 638 1357">Shaft seal arrangement: Single</p> <p data-bbox="199 1364 638 1386">Code for shaft seal: HQQE</p> <p data-bbox="199 1393 726 1415">Approvals on nameplate: CE, EAC,ACS</p> <p data-bbox="199 1422 766 1444">Curve tolerance: ISO9906:2012 3B</p> <p data-bbox="199 1482 319 1505">Materials:</p> <p data-bbox="199 1512 726 1601">Base: Stainless steel EN 1.4408 AISI 316</p> <p data-bbox="199 1608 726 1697">Impeller: Stainless steel EN 1.4401 AISI 316</p> <p data-bbox="199 1704 638 1749">Bearing: SIC Support bearing: Graflon</p> <p data-bbox="199 1787 343 1809">Installation:</p> <p data-bbox="199 1816 638 1839">Maximum ambient temperature: 60 °C</p> <p data-bbox="199 1845 638 1868">Maximum operating pressure: 16 bar</p> <p data-bbox="199 1874 742 1930">Max pressure at stated temp: 16 bar / 120 °C 16 bar / -40 °C</p> <p data-bbox="199 1937 614 1960">Type of connection: DIN</p> <p data-bbox="199 1966 654 1989">Size of inlet connection: DN 100</p> <p data-bbox="199 1995 654 2018">Size of outlet connection: DN 100</p> <p data-bbox="199 2024 686 2047">Pressure rating for pipe connection: PN 16</p> <p data-bbox="199 2054 638 2076">Flange size for motor: FF300</p>

Qty.	Description
	<p>Electrical data:</p> <p>Motor standard: IEC</p> <p>Motor type: 160MD</p> <p>IE Efficiency class: IE3</p> <p>Rated power - P2: 15 kW</p> <p>Power (P2) required by pump: 15 kW</p> <p>Mains frequency: 50 Hz</p> <p>Rated voltage: 3 x 380-415D/660-690Y V</p> <p>Rated current: 28,0-26,0/16,2-15,6 A</p> <p>Starting current: 660-780 %</p> <p>Cos phi - power factor: 0.89-0.87</p> <p>Rated speed: 2930-2950 rpm</p> <p>Efficiency: IE3 91,9%</p> <p>Motor efficiency at full load: 91.9-91.9 %</p> <p>Motor efficiency at 3/4 load: 92.4 %</p> <p>Motor efficiency at 1/2 load: 92.4 %</p> <p>Number of poles: 2</p> <p>Enclosure class (IEC 34-5): 55 Dust/Jetting</p> <p>Insulation class (IEC 85): F</p> <p>Others:</p> <p>Minimum efficiency index, MEI $\hat{\alpha}\%$: 0.70</p> <p>Net weight: 178 kg</p> <p>Gross weight: 211 kg</p> <p>Shipping volume: 0.495 m³</p> <p>Country of origin: GB</p> <p>Custom tariff no.: 84137075</p>

96692772 CRN 64-3-1 A-F-H-E-HQQE 50 Hz

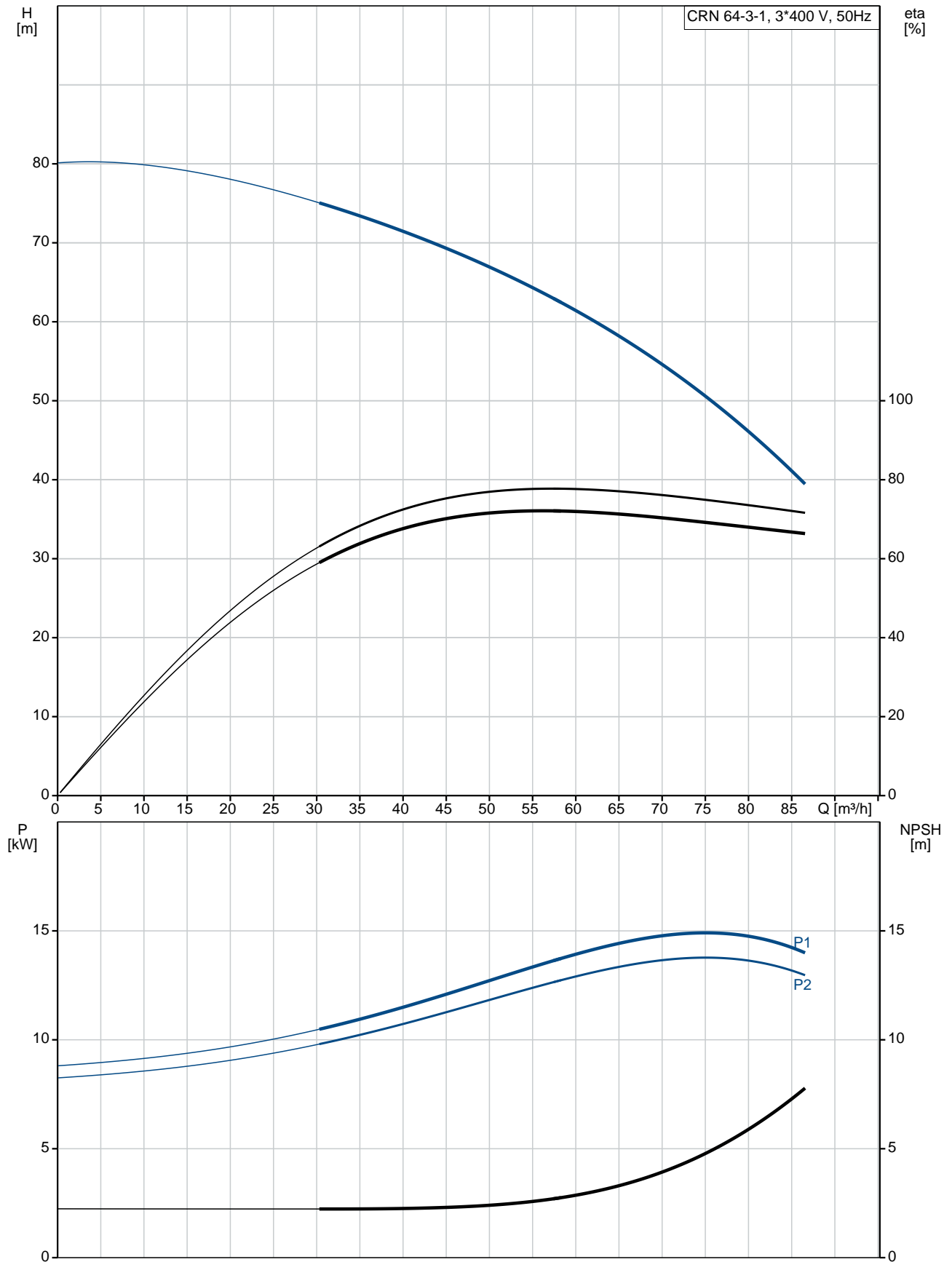

Description	Value
General information:	
Product name:	CRN 64-3-1 A-F-H-E-HQQE
Product No:	96692772
EAN number:	5700837300346
Price:	7.011,00 GBP
Technical:	
Pump speed on which pump data are based:	2923 rpm
Rated flow:	64 m ³ /h
Rated head:	59.8 m
Head max:	79.8 m
Stages:	3
Impellers:	3
Number of reduced-diameter impellers:	1
Low NPSH:	N
Pump orientation:	Vertical
Shaft seal arrangement:	Single
Code for shaft seal:	HQQE
Approvals on nameplate:	CE, EAC, ACS
Curve tolerance:	ISO9906:2012 3B
Pump version:	A
Model:	B
Materials:	
Base:	Stainless steel EN 1.4408 AISI 316
Impeller:	Stainless steel EN 1.4401 AISI 316
Material code:	H
Code for rubber:	E
Bearing:	SIC
Support bearing:	Graflon
Installation:	
Maximum ambient temperature:	60 °C
Maximum operating pressure:	16 bar
Max pressure at stated temp:	16 bar / 120 °C 16 bar / -40 °C
Type of connection:	DIN
Size of inlet connection:	DN 100
Size of outlet connection:	DN 100
Pressure rating for pipe connection:	PN 16
Flange size for motor:	FF300
Connect code:	F
Liquid:	
Pumped liquid:	Water
Liquid temperature range:	-40 .. 120 °C
Liquid temperature during operation:	20 °C
Density:	998.2 kg/m ³
Electrical data:	
Motor standard:	IEC
Motor type:	160MD
IE Efficiency class:	IE3
Rated power - P2:	15 kW
Power (P2) required by pump:	15 kW
Mains frequency:	50 Hz
Rated voltage:	3 x 380-415D/660-690Y V

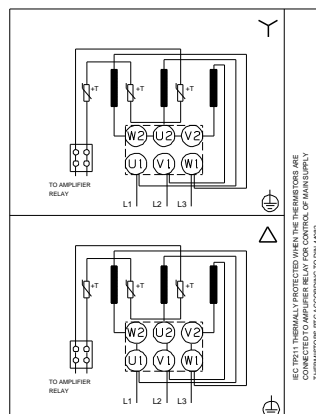
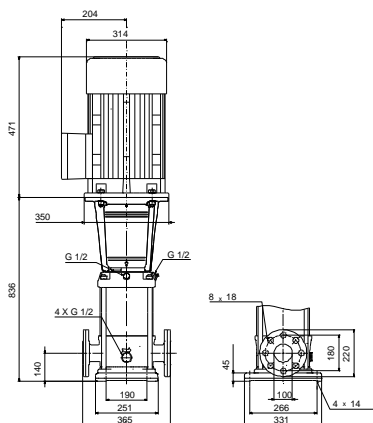
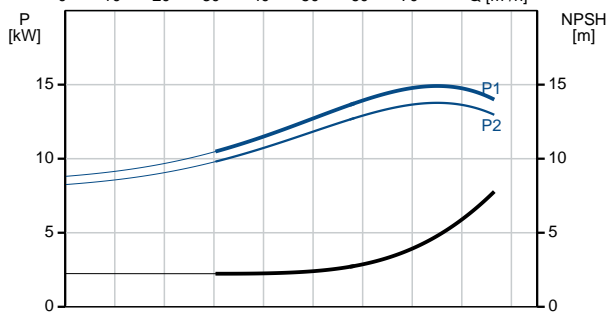
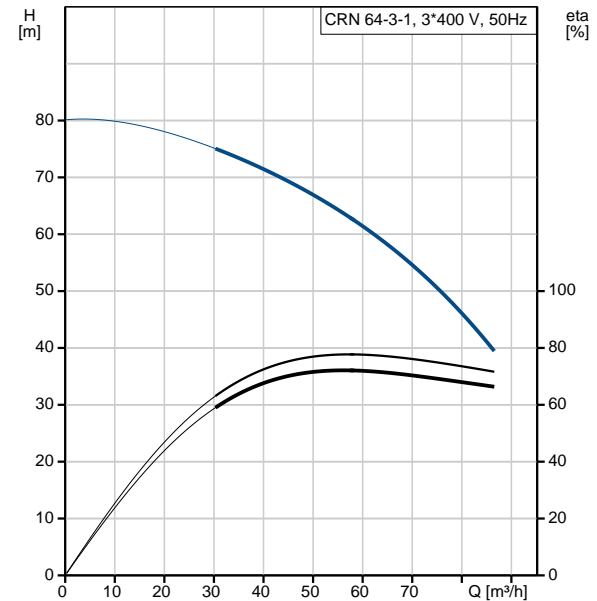



Company name:

Created by:

Phone:

Date:

12/03/2019

Description	Value
Rated current:	28,0-26,0/16,2-15,6 A
Starting current:	660-780 %
Cos phi - power factor:	0.89-0.87
Rated speed:	2930-2950 rpm
Efficiency:	IE3 91,9%
Motor efficiency at full load:	91.9-91.9 %
Motor efficiency at 3/4 load:	92.4 %
Motor efficiency at 1/2 load:	92.4 %
Number of poles:	2
Enclosure class (IEC 34-5):	55 Dust/Jetting
Insulation class (IEC 85):	F
Motor protec:	PTC
Motor No:	85U17526
Controls:	
Frequency converter:	NONE
Others:	
Minimum efficiency index, MEI η_{min} :	0.70
Net weight:	178 kg
Gross weight:	211 kg
Shipping volume:	0.495 m ³
Sales region:	Great Britain
Country of origin:	GB
Custom tariff no.:	84137075

96692772 CRN 64-3-1 A-F-H-E-HQQE 50 Hz

