

Qty. Description

1 CRN 90-5 A-F-H-E-HQQE



Product No.: [96536549](#)

Vertical, multistage centrifugal pump with inlet and outlet ports on same the level (inline). Pump materials in contact with the liquid are in high-grade stainless steel. A cartridge shaft seal ensures high reliability, safe handling, and easy access and service. Power transmission is via a rigid split coupling. Pipe connection is via DIN flanges.

The pump is fitted with a 3-phase, fan-cooled asynchronous motor.

Controls:

Frequency converter: NONE

Liquid:

Pumped liquid: Water
 Liquid temperature range: -40 .. 120 °C
 Liquid temperature during operation: 20 °C
 Density: 998.2 kg/m³

Technical:

Pump speed on which pump data are based: 2957 rpm
 Rated flow: 90 m³/h
 Rated head: 111.2 m
 Pump orientation: Vertical
 Shaft seal arrangement: Single
 Code for shaft seal: HQQE
 Approvals on nameplate: CE, EAC, ACS
 Curve tolerance: ISO9906:2012 3B

Materials:

Base: Stainless steel
 EN 1.4408
 AISI 316
 Impeller: Stainless steel
 EN 1.4401
 AISI 316
 Bearing: SIC
 Support bearing: Graflon

Installation:

Maximum ambient temperature: 55 °C
 Maximum operating pressure: 30 bar
 Max pressure at stated temp: 30 bar / 120 °C
 30 bar / -40 °C
 Type of connection: DIN
 Size of inlet connection: DN 100
 Size of outlet connection: DN 100
 Pressure rating for pipe connection: PN 40
 Flange size for motor: FF350

Qty.	Description
	<p>Electrical data:</p> <p>Motor standard: IEC</p> <p>Motor type: SIEMENS</p> <p>IE Efficiency class: IE3</p> <p>Rated power - P2: 37 kW</p> <p>Power (P2) required by pump: 37 kW</p> <p>Mains frequency: 50 Hz</p> <p>Rated voltage: 3 x 380-420D/660-725Y V</p> <p>Rated current: 68,0-63,0/39,0-36,0 A</p> <p>Starting current: 670-670 %</p> <p>Cos phi - power factor: 0.88</p> <p>Rated speed: 2955 rpm</p> <p>Efficiency: IE3 93,7%</p> <p>Motor efficiency at full load: 93.7-93.7 %</p> <p>Motor efficiency at 3/4 load: 93.9-93.9 %</p> <p>Motor efficiency at 1/2 load: 93.5-93.5 %</p> <p>Number of poles: 2</p> <p>Enclosure class (IEC 34-5): 55 Dust/Jetting</p> <p>Insulation class (IEC 85): F</p> <p>Others:</p> <p>Minimum efficiency index, MEI $\hat{\alpha}\%$: 0.70</p> <p>Net weight: 353 kg</p> <p>Gross weight: 392 kg</p> <p>Shipping volume: 0.805 m³</p>

96536549 CRN 90-5 A-F-H-E-HQQE 50 Hz

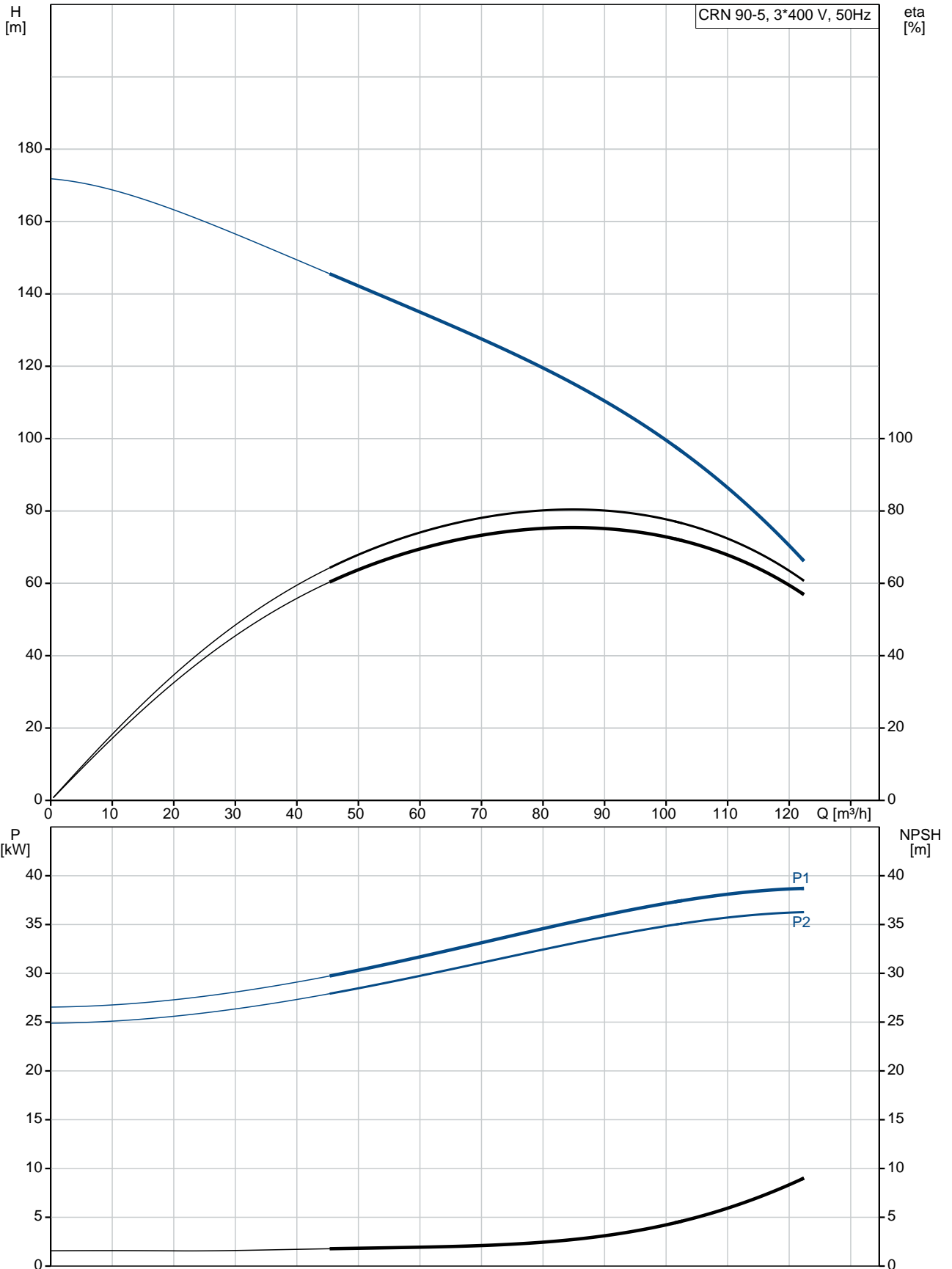

Description	Value
General information:	
Product name:	CRN 90-5 A-F-H-E-HQQE
Product No:	96536549
EAN number:	5700397575178
Technical:	
Pump speed on which pump data are based:	2957 rpm
Rated flow:	90 m ³ /h
Rated head:	111.2 m
Head max:	170.5 m
Stages:	5
Impellers:	5
Number of reduced-diameter impellers:	0
Low NPSH:	N
Pump orientation:	Vertical
Shaft seal arrangement:	Single
Code for shaft seal:	HQQE
Approvals on nameplate:	CE, EAC, ACS
Curve tolerance:	ISO9906:2012 3B
Pump version:	A
Model:	B
Materials:	
Base:	Stainless steel EN 1.4408 AISI 316
Impeller:	Stainless steel EN 1.4401 AISI 316
Material code:	H
Code for rubber:	E
Bearing:	SIC
Support bearing:	Graflon
Installation:	
Maximum ambient temperature:	55 °C
Maximum operating pressure:	30 bar
Max pressure at stated temp:	30 bar / 120 °C 30 bar / -40 °C
Type of connection:	DIN
Size of inlet connection:	DN 100
Size of outlet connection:	DN 100
Pressure rating for pipe connection:	PN 40
Flange size for motor:	FF350
Connect code:	F
Liquid:	
Pumped liquid:	Water
Liquid temperature range:	-40 .. 120 °C
Liquid temperature during operation:	20 °C
Density:	998.2 kg/m ³
Electrical data:	
Motor standard:	IEC
Motor type:	SIEMENS
IE Efficiency class:	IE3
Rated power - P2:	37 kW
Power (P2) required by pump:	37 kW
Mains frequency:	50 Hz
Rated voltage:	3 x 380-420D/660-725V V
Rated current:	68,0-63,0/39,0-36,0 A

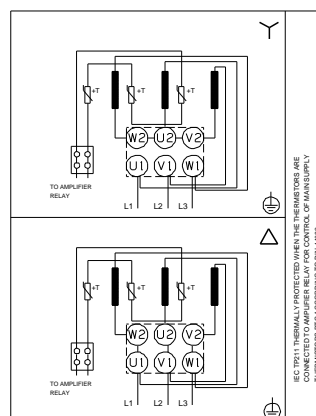
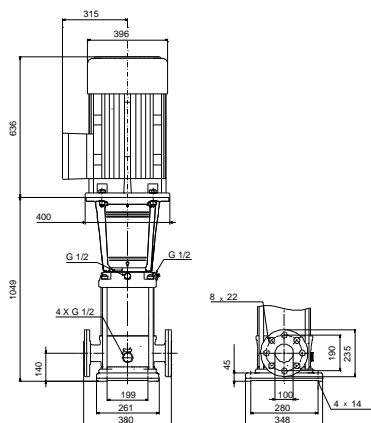
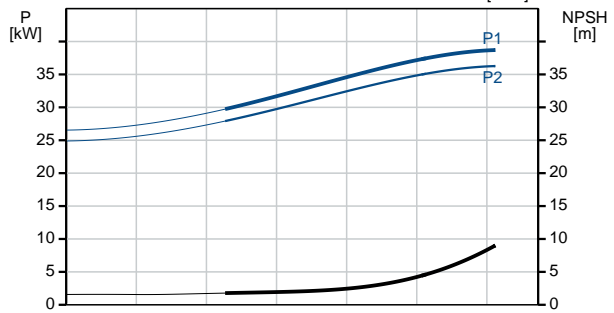
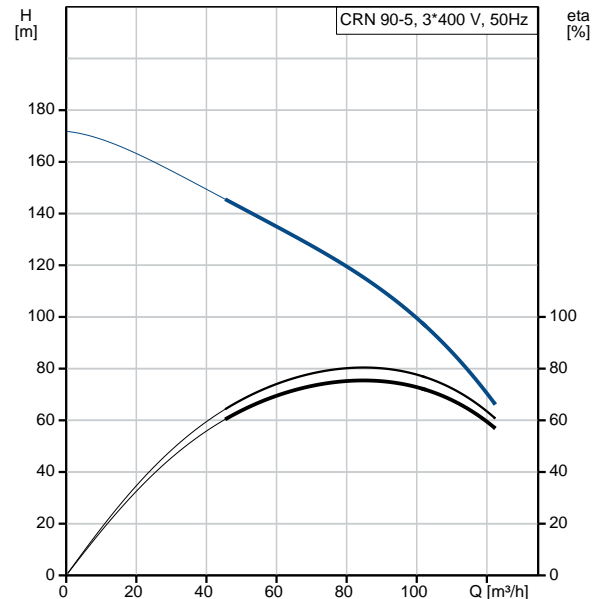



Company name:

Created by:

Phone:

Date:

12/03/2019

Description	Value
Starting current:	670-670 %
Cos phi - power factor:	0.88
Rated speed:	2955 rpm
Efficiency:	IE3 93,7%
Motor efficiency at full load:	93.7-93.7 %
Motor efficiency at 3/4 load:	93.9-93.9 %
Motor efficiency at 1/2 load:	93.5-93.5 %
Number of poles:	2
Enclosure class (IEC 34-5):	55 Dust/Jetting
Insulation class (IEC 85):	F
Motor protec:	PTC
Motor No:	81U15334
Controls:	
Frequency converter:	NONE
Others:	
Minimum efficiency index, MEI %:	0.70
Net weight:	353 kg
Gross weight:	392 kg
Shipping volume:	0.805 m ³
Sales region:	Great Britain