

Qty. Description

1 CRN 90-1-1 A-F-H-E-HQQE



Product No.: [96536542](#)

Vertical, multistage centrifugal pump with inlet and outlet ports on same the level (inline). Pump materials in contact with the liquid are in high-grade stainless steel. A cartridge shaft seal ensures high reliability, safe handling, and easy access and service. Power transmission is via a rigid split coupling. Pipe connection is via DIN flanges.

The pump is fitted with a 3-phase, fan-cooled asynchronous motor.

Controls:

Frequency converter: NONE

Liquid:

Pumped liquid: Water
 Liquid temperature range: -40 .. 120 °C
 Liquid temperature during operation: 20 °C
 Density: 998.2 kg/m³

Technical:

Pump speed on which pump data are based: 2919 rpm
 Rated flow: 90 m³/h
 Rated head: 13.1 m
 Pump orientation: Vertical
 Shaft seal arrangement: Single
 Code for shaft seal: HQQE
 Approvals on nameplate: CE, EAC, ACS
 Curve tolerance: ISO9906:2012 3B

Materials:

Base: Stainless steel
 EN 1.4408
 AISI 316
 Impeller: Stainless steel
 EN 1.4401
 AISI 316
 Bearing: SIC
 Support bearing: Graflon

Installation:

Maximum ambient temperature: 60 °C
 Maximum operating pressure: 16 bar
 Max pressure at stated temp: 16 bar / 120 °C
 16 bar / -40 °C
 Type of connection: DIN
 Size of inlet connection: DN 100
 Size of outlet connection: DN 100
 Pressure rating for pipe connection: PN 16
 Flange size for motor: FF265

Qty.	Description
	<p>Electrical data:</p> <p>Motor standard: IEC Motor type: 132SC IE Efficiency class: IE3 Rated power - P2: 5.5 kW Power (P2) required by pump: 5.5 kW Mains frequency: 50 Hz Rated voltage: 3 x 380-415D V Rated current: 11 A Starting current: 1080-1180 % Cos phi - power factor: 0.87-0.82 Rated speed: 2920-2940 rpm Efficiency: IE3 89,2% Motor efficiency at full load: 89.2 % Motor efficiency at 3/4 load: 90.0 % Motor efficiency at 1/2 load: 89.6 % Number of poles: 2 Enclosure class (IEC 34-5): 55 Dust/Jetting Insulation class (IEC 85): F</p> <p>Others:</p> <p>Minimum efficiency index, MEI $\hat{\%}$: 0.70 Net weight: 109 kg Gross weight: 132 kg Shipping volume: 0.309 m³</p>

96536542 CRN 90-1-1 A-F-H-E-HQQE 50 Hz

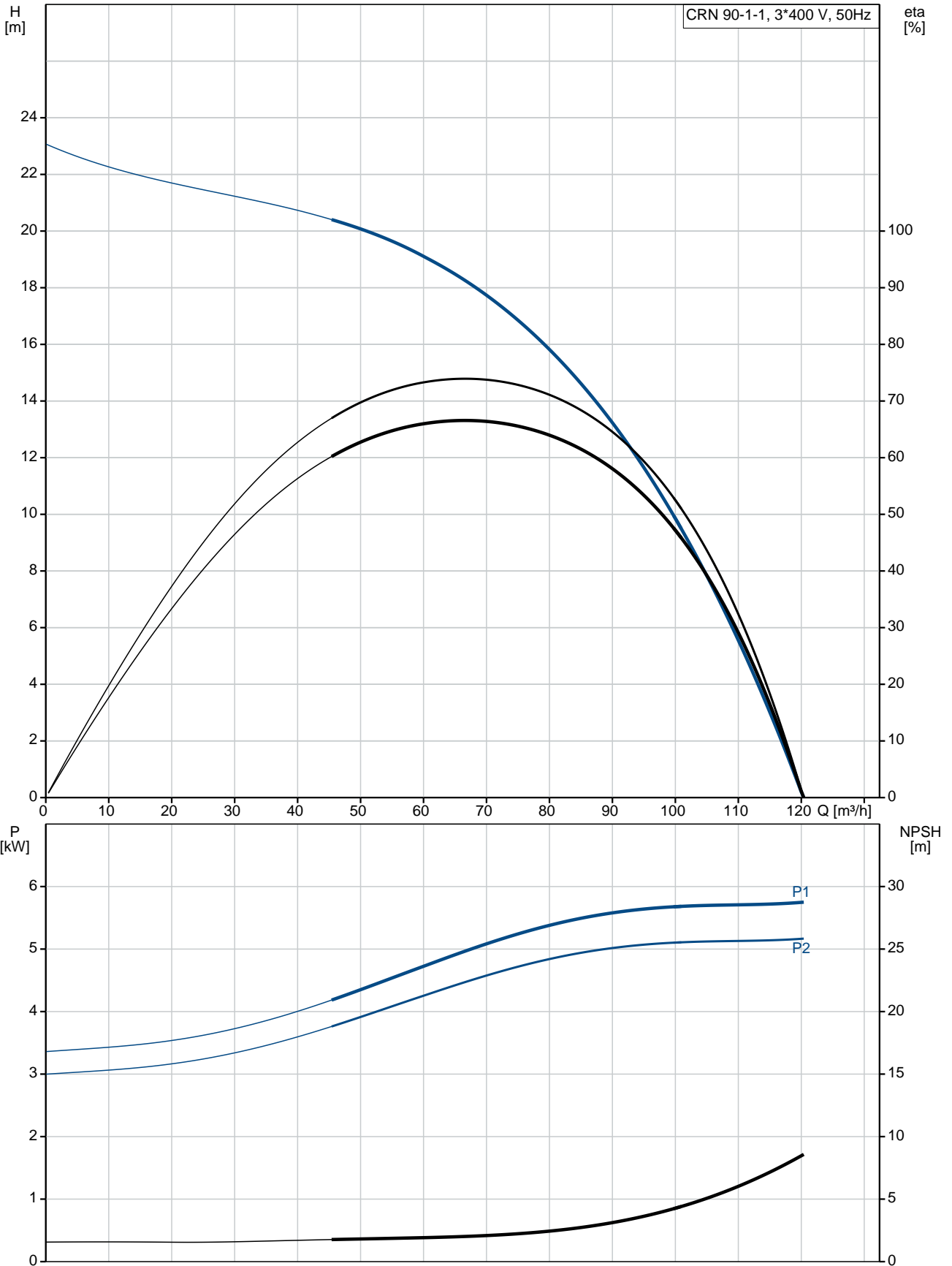

Description	Value
General information:	
Product name:	CRN 90-1-1 A-F-H-E-HQQE
Product No:	96536542
EAN number:	5700397574904
Technical:	
Pump speed on which pump data are based:	2919 rpm
Rated flow:	90 m ³ /h
Rated head:	13.1 m
Head max:	23.3 m
Stages:	1
Impellers:	1
Number of reduced-diameter impellers:	1
Low NPSH:	N
Pump orientation:	Vertical
Shaft seal arrangement:	Single
Code for shaft seal:	HQQE
Approvals on nameplate:	CE, EAC, ACS
Curve tolerance:	ISO9906:2012 3B
Pump version:	A
Model:	B
Materials:	
Base:	Stainless steel EN 1.4408 AISI 316
Impeller:	Stainless steel EN 1.4401 AISI 316
Material code:	H
Code for rubber:	E
Bearing:	SIC
Support bearing:	Graflon
Installation:	
Maximum ambient temperature:	60 °C
Maximum operating pressure:	16 bar
Max pressure at stated temp:	16 bar / 120 °C 16 bar / -40 °C
Type of connection:	DIN
Size of inlet connection:	DN 100
Size of outlet connection:	DN 100
Pressure rating for pipe connection:	PN 16
Flange size for motor:	FF265
Connect code:	F
Liquid:	
Pumped liquid:	Water
Liquid temperature range:	-40 .. 120 °C
Liquid temperature during operation:	20 °C
Density:	998.2 kg/m ³
Electrical data:	
Motor standard:	IEC
Motor type:	132SC
IE Efficiency class:	IE3
Rated power - P2:	5.5 kW
Power (P2) required by pump:	5.5 kW
Mains frequency:	50 Hz
Rated voltage:	3 x 380-415D V
Rated current:	11 A
Starting current:	1080-1180 %

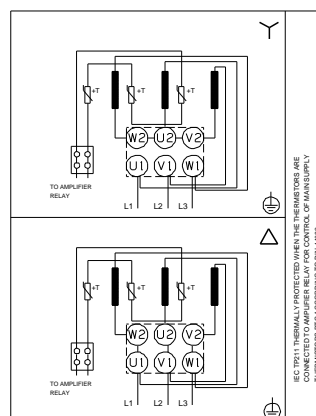
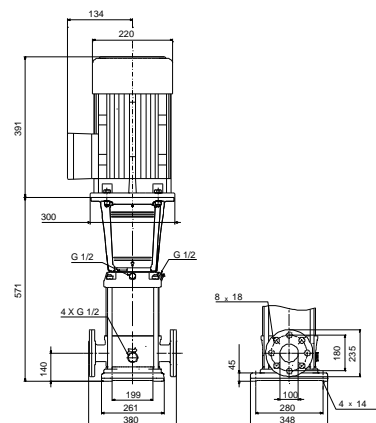
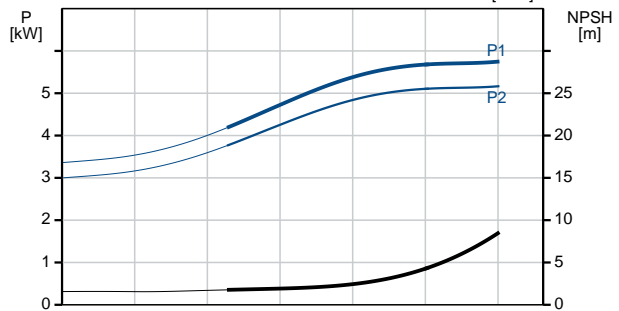
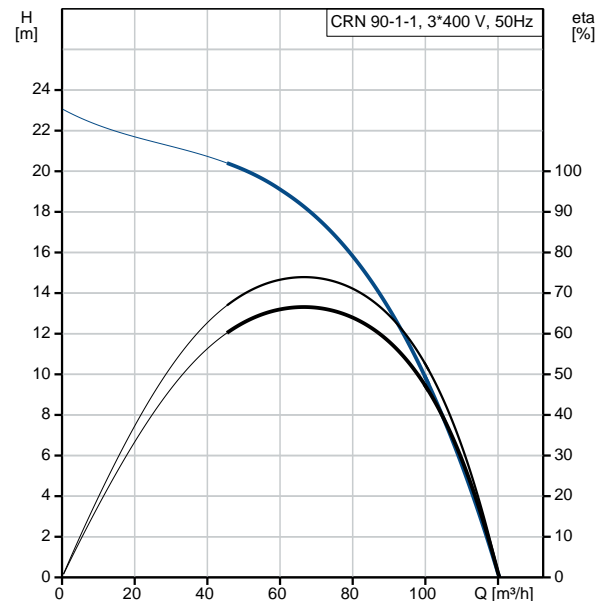



Company name:

Created by:

Phone:

Date:

12/03/2019

Description	Value
Cos phi - power factor:	0.87-0.82
Rated speed:	2920-2940 rpm
Efficiency:	IE3 89,2%
Motor efficiency at full load:	89.2 %
Motor efficiency at 3/4 load:	90.0 %
Motor efficiency at 1/2 load:	89.6 %
Number of poles:	2
Enclosure class (IEC 34-5):	55 Dust/Jetting
Insulation class (IEC 85):	F
Motor protec:	PTC
Motor No:	85U17417
Controls:	
Frequency converter:	NONE
Others:	
Minimum efficiency index, MEI %:	0.70
Net weight:	109 kg
Gross weight:	132 kg
Shipping volume:	0.309 m ³
Sales region:	Great Britain

96536542 CRN 90-1-1 A-F-H-E-HQQE 50 Hz

