

**Qty. Description**

1 CRN 45-9 A-F-H-E-HQQE



Product No.: [96536464](#)

Vertical, multistage centrifugal pump with inlet and outlet ports on same the level (inline). Pump materials in contact with the liquid are in high-grade stainless steel. A cartridge shaft seal ensures high reliability, safe handling, and easy access and service. Power transmission is via a rigid split coupling. Pipe connection is via DIN flanges.

The pump is fitted with a 3-phase, fan-cooled asynchronous motor.

**Controls:**

Frequency converter: NONE

**Liquid:**

Pumped liquid: Water  
 Liquid temperature range: -40 .. 120 °C  
 Liquid temperature during operation: 20 °C  
 Density: 998.2 kg/m<sup>3</sup>

**Technical:**

Pump speed on which pump data are based: 2957 rpm  
 Rated flow: 45 m<sup>3</sup>/h  
 Rated head: 185 m  
 Pump orientation: Vertical  
 Shaft seal arrangement: Single  
 Code for shaft seal: HQQE  
 Approvals on nameplate: CE, EAC, ACS  
 Curve tolerance: ISO9906:2012 3B

**Materials:**

Base: Stainless steel  
 EN 1.4408  
 AISI 316  
 Impeller: Stainless steel  
 EN 1.4401  
 AISI 316  
 Bearing: SIC  
 Support bearing: Graflon

**Installation:**

Maximum ambient temperature: 55 °C  
 Maximum operating pressure: 30 bar  
 Max pressure at stated temp: 30 bar / 120 °C  
 30 bar / -40 °C  
 Type of connection: DIN  
 Size of inlet connection: DN 80  
 Size of outlet connection: DN 80  
 Pressure rating for pipe connection: PN 40  
 Flange size for motor: FF350

Qty.	Description
------	-------------

**Electrical data:**

Motor standard:	IEC
Motor type:	SIEMENS
IE Efficiency class:	IE3
Rated power - P2:	37 kW
Power (P2) required by pump:	37 kW
Mains frequency:	50 Hz
Rated voltage:	3 x 380-420D/660-725Y V
Rated current:	68,0-63,0/39,0-36,0 A
Starting current:	670-670 %
Cos phi - power factor:	0.88
Rated speed:	2955 rpm
Efficiency:	IE3 93,7%
Motor efficiency at full load:	93.7-93.7 %
Motor efficiency at 3/4 load:	93.9-93.9 %
Motor efficiency at 1/2 load:	93.5-93.5 %
Number of poles:	2
Enclosure class (IEC 34-5):	55 Dust/Jetting
Insulation class (IEC 85):	F

**Others:**

Minimum efficiency index, MEI $\hat{\alpha}\%$ :	0.70
Net weight:	357 kg
Gross weight:	402 kg
Shipping volume:	0.808 m <sup>3</sup>
Country of origin:	GB
Custom tariff no.:	84137075

## 96536464 CRN 45-9 A-F-H-E-HQQE 50 Hz

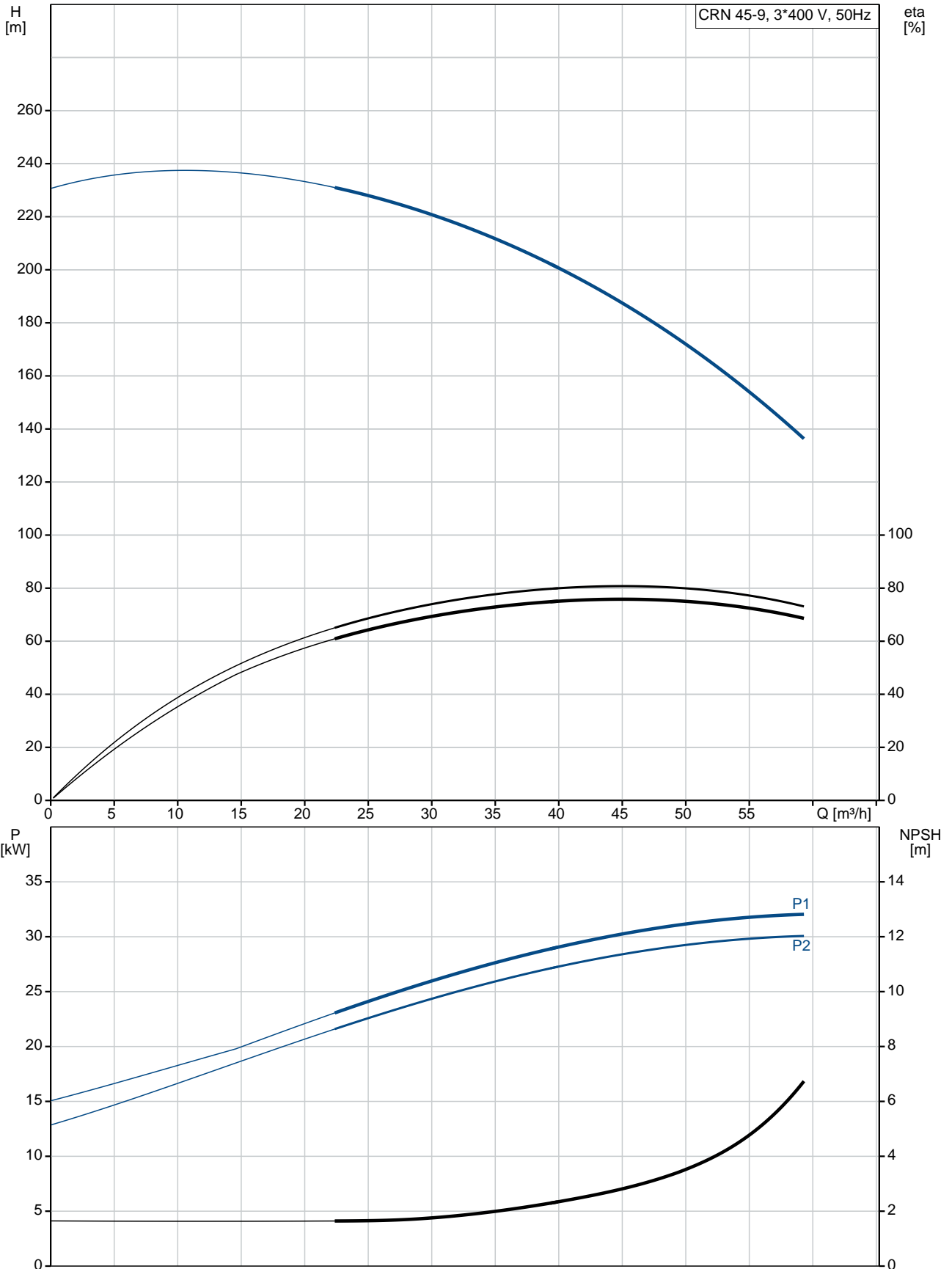

Description	Value
<b>General information:</b>	
Product name:	CRN 45-9 A-F-H-E-HQQE
Product No:	96536464
EAN number:	5700397572146
<b>Technical:</b>	
Pump speed on which pump data are based:	2957 rpm
Rated flow:	45 m <sup>3</sup> /h
Rated head:	185 m
Head max:	230.2 m
Stages:	9
Impellers:	9
Number of reduced-diameter impellers:	0
Low NPSH:	N
Pump orientation:	Vertical
Shaft seal arrangement:	Single
Code for shaft seal:	HQQE
Approvals on nameplate:	CE, EAC, ACS
Curve tolerance:	ISO9906:2012 3B
Pump version:	A
Model:	B
<b>Materials:</b>	
Base:	Stainless steel EN 1.4408 AISI 316
Impeller:	Stainless steel EN 1.4401 AISI 316
Material code:	H
Code for rubber:	E
Bearing:	SIC
Support bearing:	Graflon
<b>Installation:</b>	
Maximum ambient temperature:	55 °C
Maximum operating pressure:	30 bar
Max pressure at stated temp:	30 bar / 120 °C 30 bar / -40 °C
Type of connection:	DIN
Size of inlet connection:	DN 80
Size of outlet connection:	DN 80
Pressure rating for pipe connection:	PN 40
Flange size for motor:	FF350
Connect code:	F
<b>Liquid:</b>	
Pumped liquid:	Water
Liquid temperature range:	-40 .. 120 °C
Liquid temperature during operation:	20 °C
Density:	998.2 kg/m <sup>3</sup>
<b>Electrical data:</b>	
Motor standard:	IEC
Motor type:	SIEMENS
IE Efficiency class:	IE3
Rated power - P2:	37 kW
Power (P2) required by pump:	37 kW
Mains frequency:	50 Hz
Rated voltage:	3 x 380-420D/660-725V
Rated current:	68,0-63,0/39,0-36,0 A

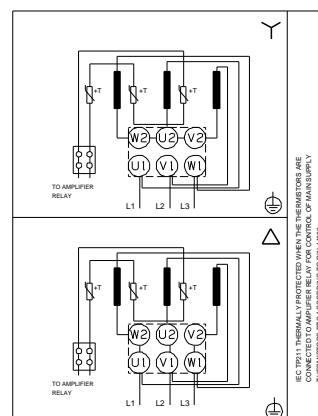
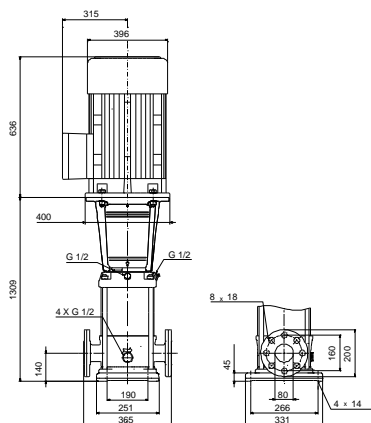
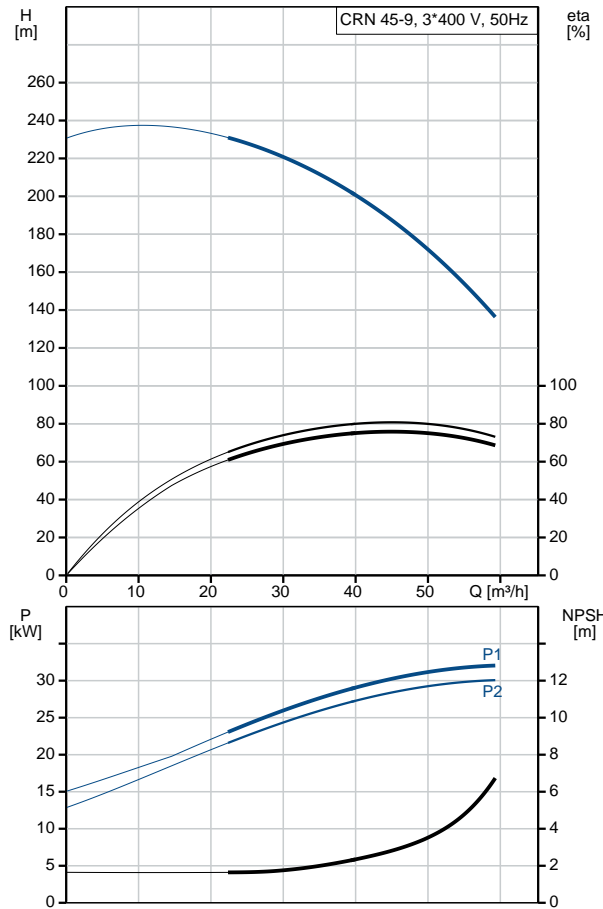



Company name:

Created by:

Phone:

Date:

12/03/2019

Description	Value
Starting current:	670-670 %
Cos phi - power factor:	0.88
Rated speed:	2955 rpm
Efficiency:	IE3 93,7%
Motor efficiency at full load:	93.7-93.7 %
Motor efficiency at 3/4 load:	93.9-93.9 %
Motor efficiency at 1/2 load:	93.5-93.5 %
Number of poles:	2
Enclosure class (IEC 34-5):	55 Dust/Jetting
Insulation class (IEC 85):	F
Motor protec:	PTC
Motor No:	81U15334
<b>Controls:</b>	
Frequency converter:	NONE
<b>Others:</b>	
Minimum efficiency index, MEI %:	0.70
Net weight:	357 kg
Gross weight:	402 kg
Shipping volume:	0.808 m <sup>3</sup>
Sales region:	Great Britain
Country of origin:	GB
Custom tariff no.:	84137075