

Qty. Description

1 CRN 45-7 A-F-H-E-HQQE



Product No.: [96536460](#)

Vertical, multistage centrifugal pump with inlet and outlet ports on same the level (inline). Pump materials in contact with the liquid are in high-grade stainless steel. A cartridge shaft seal ensures high reliability, safe handling, and easy access and service. Power transmission is via a rigid split coupling. Pipe connection is via DIN flanges.

The pump is fitted with a 3-phase, fan-cooled asynchronous motor.

Controls:

Frequency converter: NONE

Liquid:

Pumped liquid: Water
 Liquid temperature range: -40 .. 120 °C
 Liquid temperature during operation: 20 °C
 Density: 998.2 kg/m³

Technical:

Pump speed on which pump data are based: 2951 rpm
 Rated flow: 45 m³/h
 Rated head: 143.9 m
 Pump orientation: Vertical
 Shaft seal arrangement: Single
 Code for shaft seal: HQQE
 Approvals on nameplate: CE, EAC, ACS
 Curve tolerance: ISO9906:2012 3B

Materials:

Base: Stainless steel
 EN 1.4408
 AISI 316
 Impeller: Stainless steel
 EN 1.4401
 AISI 316
 Bearing: SIC
 Support bearing: Graflon

Installation:

Maximum ambient temperature: 55 °C
 Maximum operating pressure: 30 bar
 Max pressure at stated temp: 30 bar / 120 °C
 30 bar / -40 °C
 Type of connection: DIN
 Size of inlet connection: DN 80
 Size of outlet connection: DN 80
 Pressure rating for pipe connection: PN 40
 Flange size for motor: FF350

Qty. Description

Electrical data:

Motor standard:	IEC
Motor type:	SIEMENS
IE Efficiency class:	IE3
Rated power - P2:	30 kW
Power (P2) required by pump:	30 kW
Mains frequency:	50 Hz
Rated voltage:	3 x 380-420D/660-725Y V
Rated current:	56,0-51,0/32,0-29,5 A
Starting current:	660-660 %
Cos phi - power factor:	0.87
Rated speed:	2955 rpm
Efficiency:	IE3 93,3%
Motor efficiency at full load:	93.3-93.3 %
Motor efficiency at 3/4 load:	93.6-93.6 %
Motor efficiency at 1/2 load:	93.4-93.4 %
Number of poles:	2
Enclosure class (IEC 34-5):	55 Dust/Jetting
Insulation class (IEC 85):	F

Others:

Minimum efficiency index, MEI $\hat{\alpha}\%$:	0.70
Net weight:	323 kg
Gross weight:	362 kg
Shipping volume:	0.805 m ³
Country of origin:	GB
Custom tariff no.:	84137075

96536460 CRN 45-7 A-F-H-E-HQQE 50 Hz

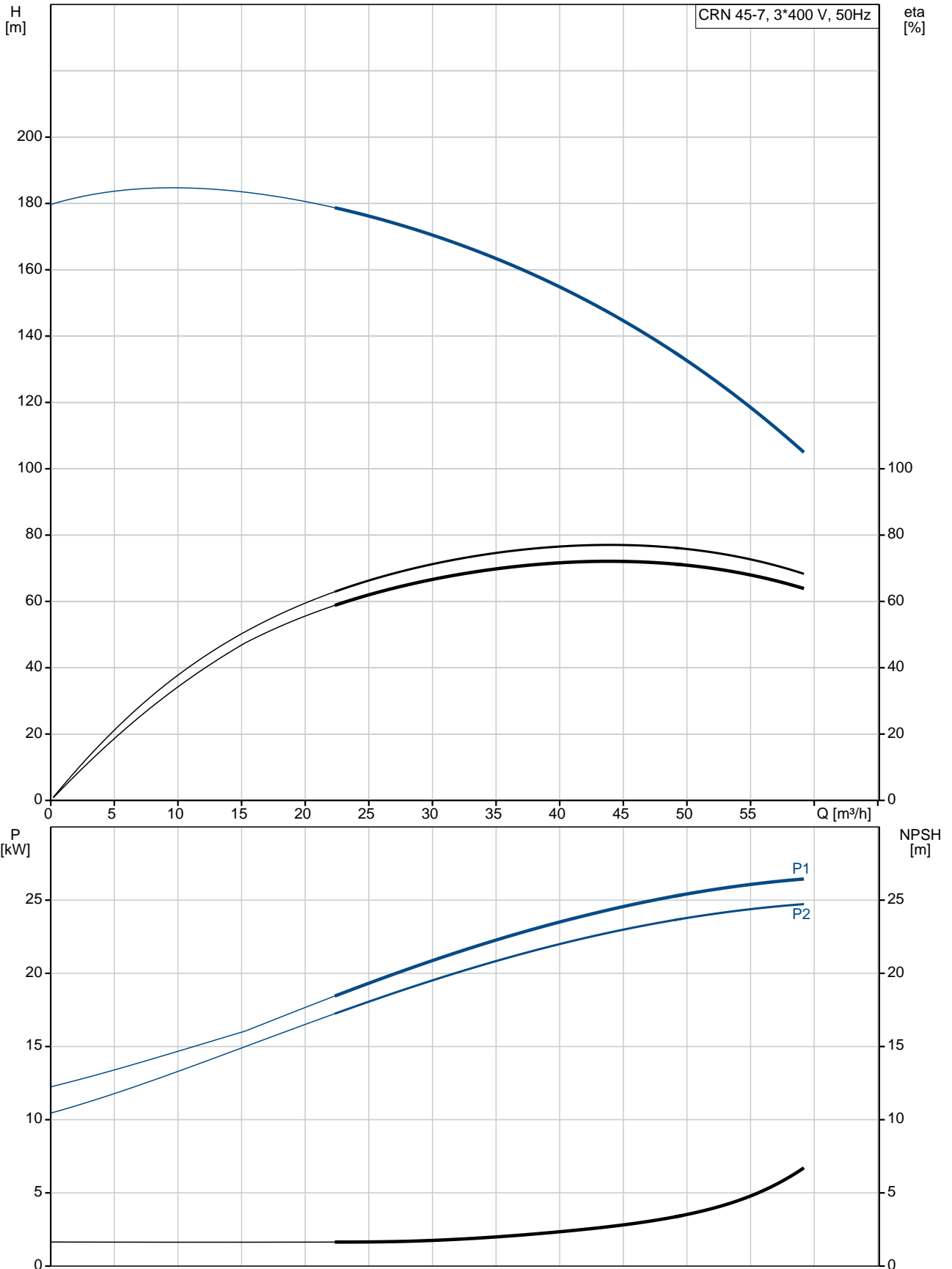

Description	Value
General information:	
Product name:	CRN 45-7 A-F-H-E-HQQE
Product No:	96536460
EAN number:	5700397572108
Technical:	
Pump speed on which pump data are based:	2951 rpm
Rated flow:	45 m ³ /h
Rated head:	143.9 m
Head max:	179.4 m
Stages:	7
Impellers:	7
Number of reduced-diameter impellers:	0
Low NPSH:	N
Pump orientation:	Vertical
Shaft seal arrangement:	Single
Code for shaft seal:	HQQE
Approvals on nameplate:	CE, EAC, ACS
Curve tolerance:	ISO9906:2012 3B
Pump version:	A
Model:	B
Materials:	
Base:	Stainless steel EN 1.4408 AISI 316
Impeller:	Stainless steel EN 1.4401 AISI 316
Material code:	H
Code for rubber:	E
Bearing:	SIC
Support bearing:	Graflon
Installation:	
Maximum ambient temperature:	55 °C
Maximum operating pressure:	30 bar
Max pressure at stated temp:	30 bar / 120 °C 30 bar / -40 °C
Type of connection:	DIN
Size of inlet connection:	DN 80
Size of outlet connection:	DN 80
Pressure rating for pipe connection:	PN 40
Flange size for motor:	FF350
Connect code:	F
Liquid:	
Pumped liquid:	Water
Liquid temperature range:	-40 .. 120 °C
Liquid temperature during operation:	20 °C
Density:	998.2 kg/m ³
Electrical data:	
Motor standard:	IEC
Motor type:	SIEMENS
IE Efficiency class:	IE3
Rated power - P2:	30 kW
Power (P2) required by pump:	30 kW
Mains frequency:	50 Hz
Rated voltage:	3 x 380-420D/660-725V V
Rated current:	56,0-51,0/32,0-29,5 A

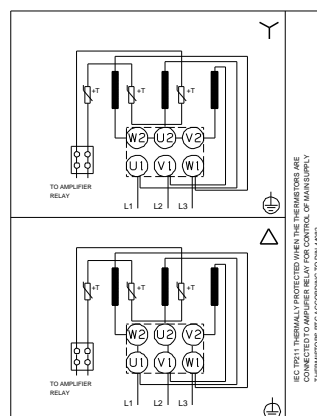
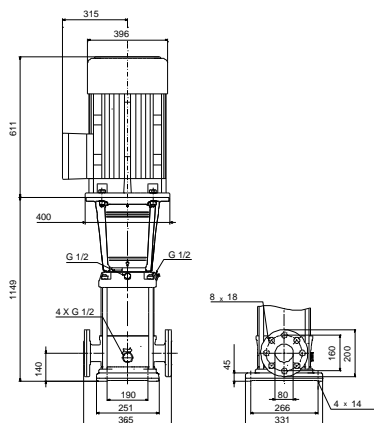
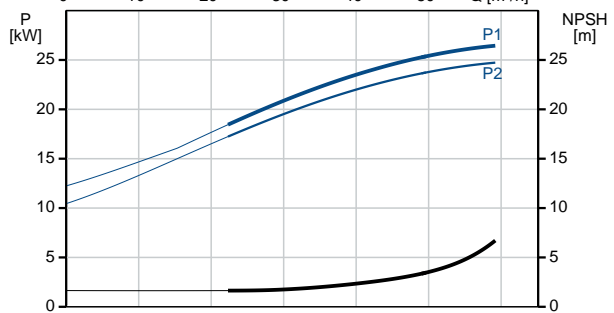
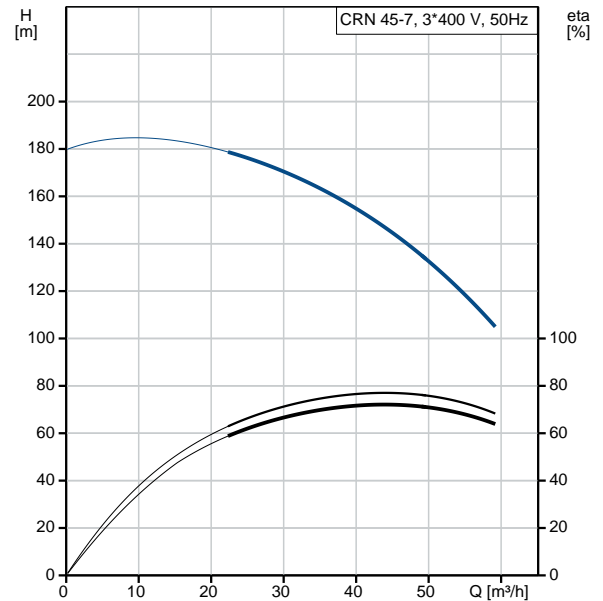



Company name:

Created by:

Phone:

Date:

12/03/2019

Description	Value
Starting current:	660-660 %
Cos phi - power factor:	0.87
Rated speed:	2955 rpm
Efficiency:	IE3 93,3%
Motor efficiency at full load:	93.3-93.3 %
Motor efficiency at 3/4 load:	93.6-93.6 %
Motor efficiency at 1/2 load:	93.4-93.4 %
Number of poles:	2
Enclosure class (IEC 34-5):	55 Dust/Jetting
Insulation class (IEC 85):	F
Motor protec:	PTC
Motor No:	81U15332
Controls:	
Frequency converter:	NONE
Others:	
Minimum efficiency index, MEI %:	0.70
Net weight:	323 kg
Gross weight:	362 kg
Shipping volume:	0.805 m ³
Sales region:	Great Britain
Country of origin:	GB
Custom tariff no.:	84137075