

Qty.	Description
1	<p data-bbox="199 338 531 367"><b>CRN 32-12-2 A-F-H-E-HQQE</b></p>  <p data-bbox="199 660 469 689">Product No.: <a href="#">96536160</a></p> <p data-bbox="199 719 1453 822">Vertical, multistage centrifugal pump with inlet and outlet ports on same the level (inline). Pump materials in contact with the liquid are in high-grade stainless steel. A cartridge shaft seal ensures high reliability, safe handling, and easy access and service. Power transmission is via a rigid split coupling. Pipe connection is via DIN flanges.</p> <p data-bbox="199 862 935 891">The pump is fitted with a 3-phase, fan-cooled asynchronous motor.</p> <p data-bbox="199 920 316 949"><b>Controls:</b></p> <p data-bbox="199 952 638 981">Frequency converter: NONE</p> <p data-bbox="199 1010 288 1039"><b>Liquid:</b></p> <p data-bbox="199 1041 707 1160">Pumped liquid: Water Liquid temperature range: -40 .. 120 °C Liquid temperature during operation: 20 °C Density: 998.2 kg/m<sup>3</sup></p> <p data-bbox="199 1189 328 1218"><b>Technical:</b></p> <p data-bbox="199 1220 820 1456">Pump speed on which pump data are based: 2947 rpm Rated flow: 30 m<sup>3</sup>/h Rated head: 177.5 m Pump orientation: Vertical Shaft seal arrangement: Single Code for shaft seal: HQQE Approvals on nameplate: CE, EAC, ACS Curve tolerance: ISO9906:2012 3B</p> <p data-bbox="199 1485 320 1514"><b>Materials:</b></p> <p data-bbox="199 1516 727 1753">Base: Stainless steel EN 1.4408 AISI 316 Impeller: Stainless steel EN 1.4401 AISI 316 Bearing: SIC Support bearing: Graflon</p> <p data-bbox="199 1783 344 1812"><b>Installation:</b></p> <p data-bbox="199 1814 742 2078">Maximum ambient temperature: 60 °C Maximum operating pressure: 30 bar Max pressure at stated temp: 30 bar / 120 °C 30 bar / -40 °C Type of connection: DIN Size of inlet connection: DN 65 Size of outlet connection: DN 65 Pressure rating for pipe connection: PN 40 Flange size for motor: FF300</p>

Qty.	Description
	<p><b>Electrical data:</b></p> <p>Motor standard: IEC</p> <p>Motor type: 180MB</p> <p>IE Efficiency class: IE3</p> <p>Rated power - P2: 22 kW</p> <p>Power (P2) required by pump: 22 kW</p> <p>Mains frequency: 50 Hz</p> <p>Rated voltage: 3 x 380-415D/660-690Y V</p> <p>Rated current: 39.5/22.8 A</p> <p>Starting current: 830 %</p> <p>Cos phi - power factor: 0.90-0.90</p> <p>Rated speed: 2950 rpm</p> <p>Efficiency: IE3 92,7%</p> <p>Motor efficiency at full load: 92.7-92.7 %</p> <p>Motor efficiency at 3/4 load: 93.7 %</p> <p>Motor efficiency at 1/2 load: 94.4 %</p> <p>Number of poles: 2</p> <p>Enclosure class (IEC 34-5): 55 Dust/Jetting</p> <p>Insulation class (IEC 85): F</p> <p><b>Others:</b></p> <p>Minimum efficiency index, MEI <math>\hat{\alpha}\%</math>: 0.70</p> <p>Net weight: 224 kg</p> <p>Gross weight: 269 kg</p> <p>Shipping volume: 0.808 m<sup>3</sup></p> <p>Country of origin: GB</p> <p>Custom tariff no.: 84137075</p>

## 96536160 CRN 32-12-2 A-F-H-E-HQQE 50 Hz

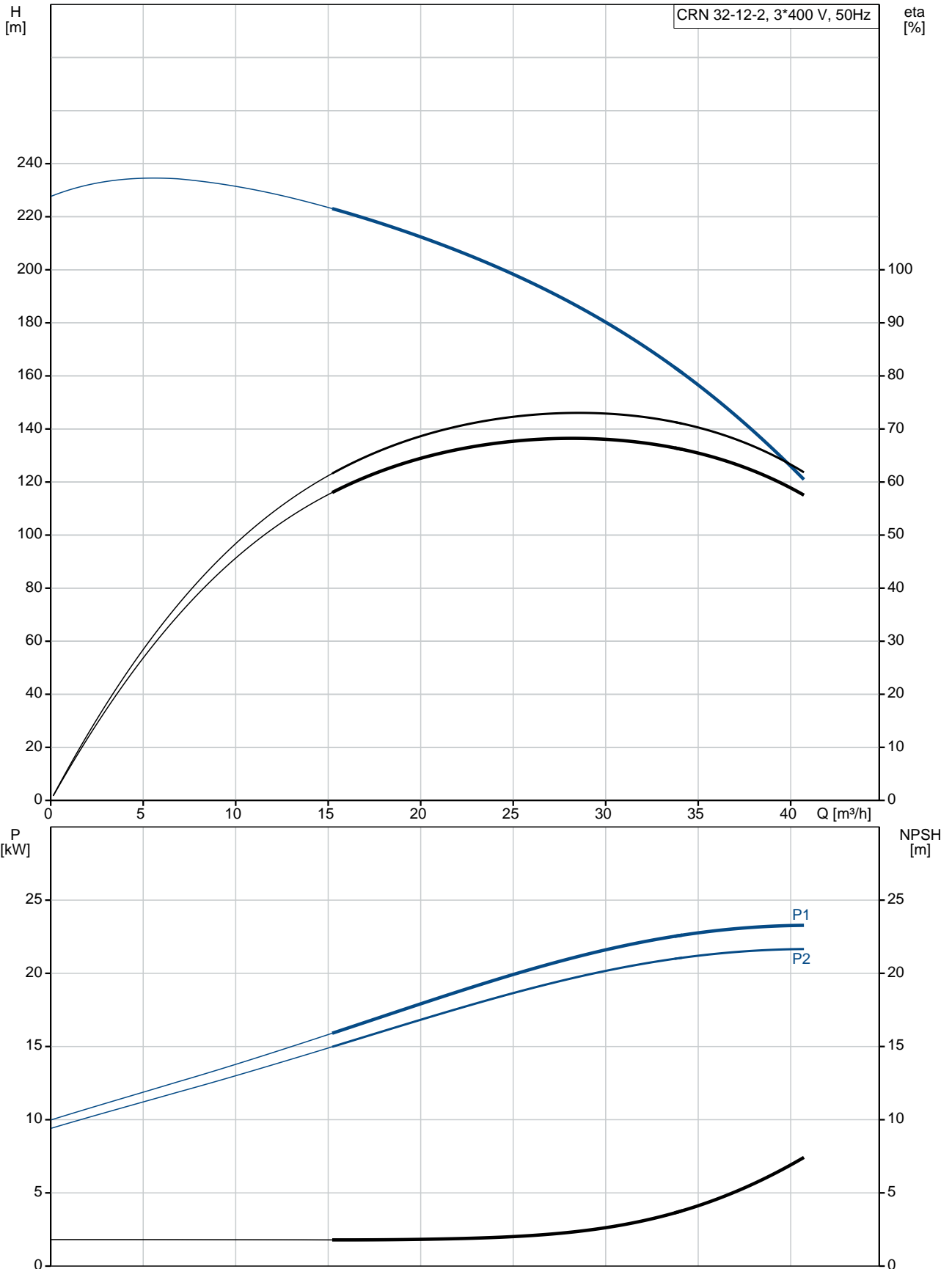

Description	Value
<b>General information:</b>	
Product name:	CRN 32-12-2 A-F-H-E-HQQE
Product No:	96536160
EAN number:	5700397564233
Price:	9.773,00 GBP
<b>Technical:</b>	
Pump speed on which pump data are based:	2947 rpm
Rated flow:	30 m <sup>3</sup> /h
Rated head:	177.5 m
Head max:	226.1 m
Stages:	12
Impellers:	12
Number of reduced-diameter impellers:	2
Low NPSH:	N
Pump orientation:	Vertical
Shaft seal arrangement:	Single
Code for shaft seal:	HQQE
Approvals on nameplate:	CE, EAC, ACS
Curve tolerance:	ISO9906:2012 3B
Pump version:	A
Model:	B
<b>Materials:</b>	
Base:	Stainless steel EN 1.4408 AISI 316
Impeller:	Stainless steel EN 1.4401 AISI 316
Material code:	H
Code for rubber:	E
Bearing:	SIC
Support bearing:	Graflon
<b>Installation:</b>	
Maximum ambient temperature:	60 °C
Maximum operating pressure:	30 bar
Max pressure at stated temp:	30 bar / 120 °C 30 bar / -40 °C
Type of connection:	DIN
Size of inlet connection:	DN 65
Size of outlet connection:	DN 65
Pressure rating for pipe connection:	PN 40
Flange size for motor:	FF300
Connect code:	F
<b>Liquid:</b>	
Pumped liquid:	Water
Liquid temperature range:	-40 .. 120 °C
Liquid temperature during operation:	20 °C
Density:	998.2 kg/m <sup>3</sup>
<b>Electrical data:</b>	
Motor standard:	IEC
Motor type:	180MB
IE Efficiency class:	IE3
Rated power - P2:	22 kW
Power (P2) required by pump:	22 kW
Mains frequency:	50 Hz
Rated voltage:	3 x 380-415D/660-690Y V

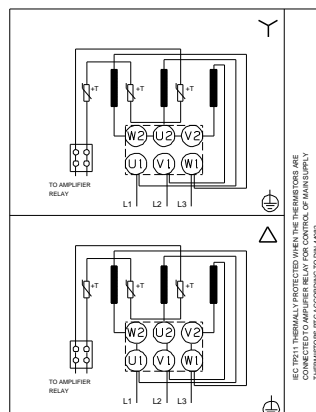
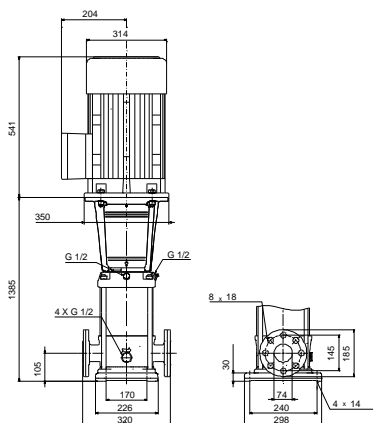
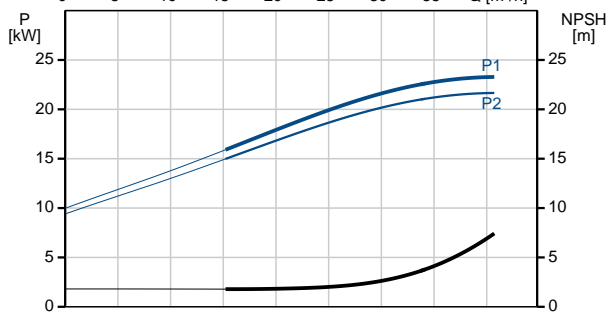
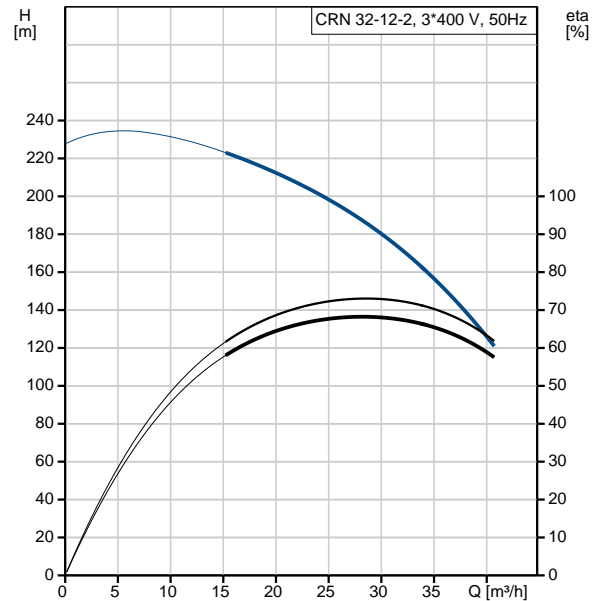



Company name:

Created by:

Phone:

Date:

12/03/2019

Description	Value
Rated current:	39.5/22.8 A
Starting current:	830 %
Cos phi - power factor:	0.90-0.90
Rated speed:	2950 rpm
Efficiency:	IE3 92,7%
Motor efficiency at full load:	92.7-92.7 %
Motor efficiency at 3/4 load:	93.7 %
Motor efficiency at 1/2 load:	94.4 %
Number of poles:	2
Enclosure class (IEC 34-5):	55 Dust/Jetting
Insulation class (IEC 85):	F
Motor protec:	PTC
Motor No:	85U17530
<b>Controls:</b>	
Frequency converter:	NONE
<b>Others:</b>	
Minimum efficiency index, MEI $\eta_{min}$ :	0.70
Net weight:	224 kg
Gross weight:	269 kg
Shipping volume:	0.808 m <sup>3</sup>
Sales region:	Great Britain
Country of origin:	GB
Custom tariff no.:	84137075

## 96536160 CRN 32-12-2 A-F-H-E-HQQE 50 Hz

