

Qty.	Description
1	<p data-bbox="199 336 526 369">CRN 10-4 A-FGJ-H-E-HQQE</p>  <p data-bbox="199 660 470 683">Product No.: 96527743</p> <p data-bbox="199 716 1404 817">Vertical, multistage centrifugal pump with inlet and outlet ports on same the level (inline). Pump materials in contact with the liquid are in high-grade stainless steel. A cartridge shaft seal ensures high reliability, safe handling, and easy access and service. Power transmission is via a rigid split coupling. Pipe connection is via combined DIN-ANSI-JIS flanges.</p> <p data-bbox="199 862 933 884">The pump is fitted with a 3-phase, fan-cooled asynchronous motor.</p> <p data-bbox="199 918 319 940">Controls:</p> <p data-bbox="199 952 638 974">Frequency converter: NONE</p> <p data-bbox="199 1008 287 1030">Liquid:</p> <p data-bbox="199 1041 638 1064">Pumped liquid: Water</p> <p data-bbox="199 1070 710 1093">Liquid temperature range: -20 .. 120 °C</p> <p data-bbox="199 1099 686 1122">Liquid temperature during operation: 20 °C</p> <p data-bbox="199 1128 702 1151">Density: 998.2 kg/m³</p> <p data-bbox="199 1187 327 1209">Technical:</p> <p data-bbox="199 1220 821 1243">Pump speed on which pump data are based: 2896 rpm</p> <p data-bbox="199 1249 654 1272">Rated flow: 10 m³/h</p> <p data-bbox="199 1279 646 1301">Rated head: 31.9 m</p> <p data-bbox="199 1308 646 1330">Pump orientation: Vertical</p> <p data-bbox="199 1337 638 1359">Shaft seal arrangement: Single</p> <p data-bbox="199 1366 638 1388">Code for shaft seal: HQQE</p> <p data-bbox="199 1395 726 1417">Approvals on nameplate: CE, EAC,ACS</p> <p data-bbox="199 1424 766 1447">Curve tolerance: ISO9906:2012 3B</p> <p data-bbox="199 1482 319 1505">Materials:</p> <p data-bbox="199 1516 726 1601">Base: Stainless steel EN 1.4408 AISI 316</p> <p data-bbox="199 1608 726 1693">Impeller: Stainless steel EN 1.4401 AISI 316</p> <p data-bbox="199 1700 606 1722">Bearing: SIC</p> <p data-bbox="199 1758 343 1780">Installation:</p> <p data-bbox="199 1787 630 1809">Maximum ambient temperature: 60 °C</p> <p data-bbox="199 1816 638 1839">Maximum operating pressure: 25 bar</p> <p data-bbox="199 1845 742 1899">Max pressure at stated temp: 25 bar / 120 °C 25 bar / -20 °C</p> <p data-bbox="199 1906 742 1928">Type of connection: DIN / ANSI / JIS</p> <p data-bbox="199 1935 638 1957">Size of inlet connection: DN 40 1 1/2 inch</p> <p data-bbox="199 1964 638 2018">Size of outlet connection: DN 40 1 1/2 inch</p> <p data-bbox="199 2024 686 2047">Pressure rating for pipe connection: PN 25</p> <p data-bbox="199 2054 638 2076">Flange rating inlet: 300 lb</p>

Qty.	Description
	<p>Flange size for motor: FT115</p> <p>Electrical data:</p> <p>Motor standard: IEC</p> <p>Motor type: 90SB</p> <p>IE Efficiency class: IE3</p> <p>Rated power - P2: 1.5 kW</p> <p>Power (P2) required by pump: 1.5 kW</p> <p>Mains frequency: 50 Hz</p> <p>Rated voltage: 3 x 220-240D/380-415Y V</p> <p>Rated current: 5.45/3.15 A</p> <p>Starting current: 850-930 %</p> <p>Cos phi - power factor: 0.87-0.82</p> <p>Rated speed: 2890-2910 rpm</p> <p>Efficiency: IE3 84,2%</p> <p>Motor efficiency at full load: 84.2 %</p> <p>Motor efficiency at 3/4 load: 84.5 %</p> <p>Motor efficiency at 1/2 load: 83.1 %</p> <p>Number of poles: 2</p> <p>Enclosure class (IEC 34-5): 55 Dust/Jetting</p> <p>Insulation class (IEC 85): F</p> <p>Others:</p> <p>Minimum efficiency index, MEI $\hat{\alpha}\%$: 0.70</p> <p>Net weight: 46 kg</p> <p>Gross weight: 49 kg</p> <p>Shipping volume: 0.094 m³</p> <p>Country of origin: GB</p> <p>Custom tariff no.: 84137075</p>

96527743 CRN 10-4 A-FGJ-H-E-HQQE 50 Hz

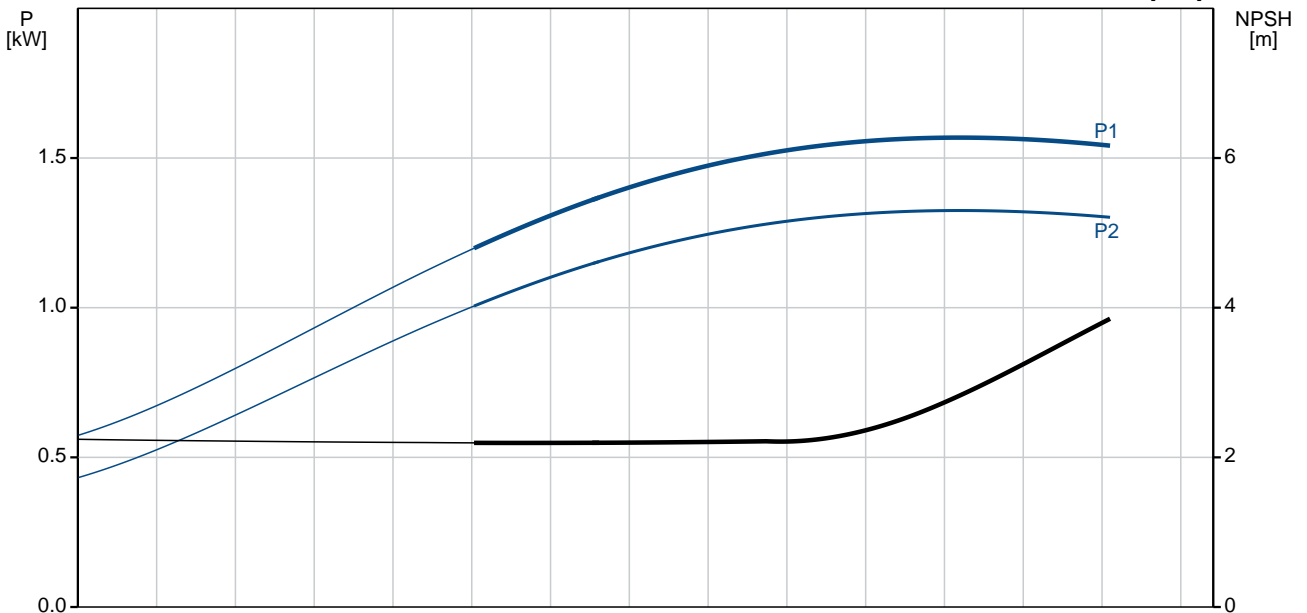
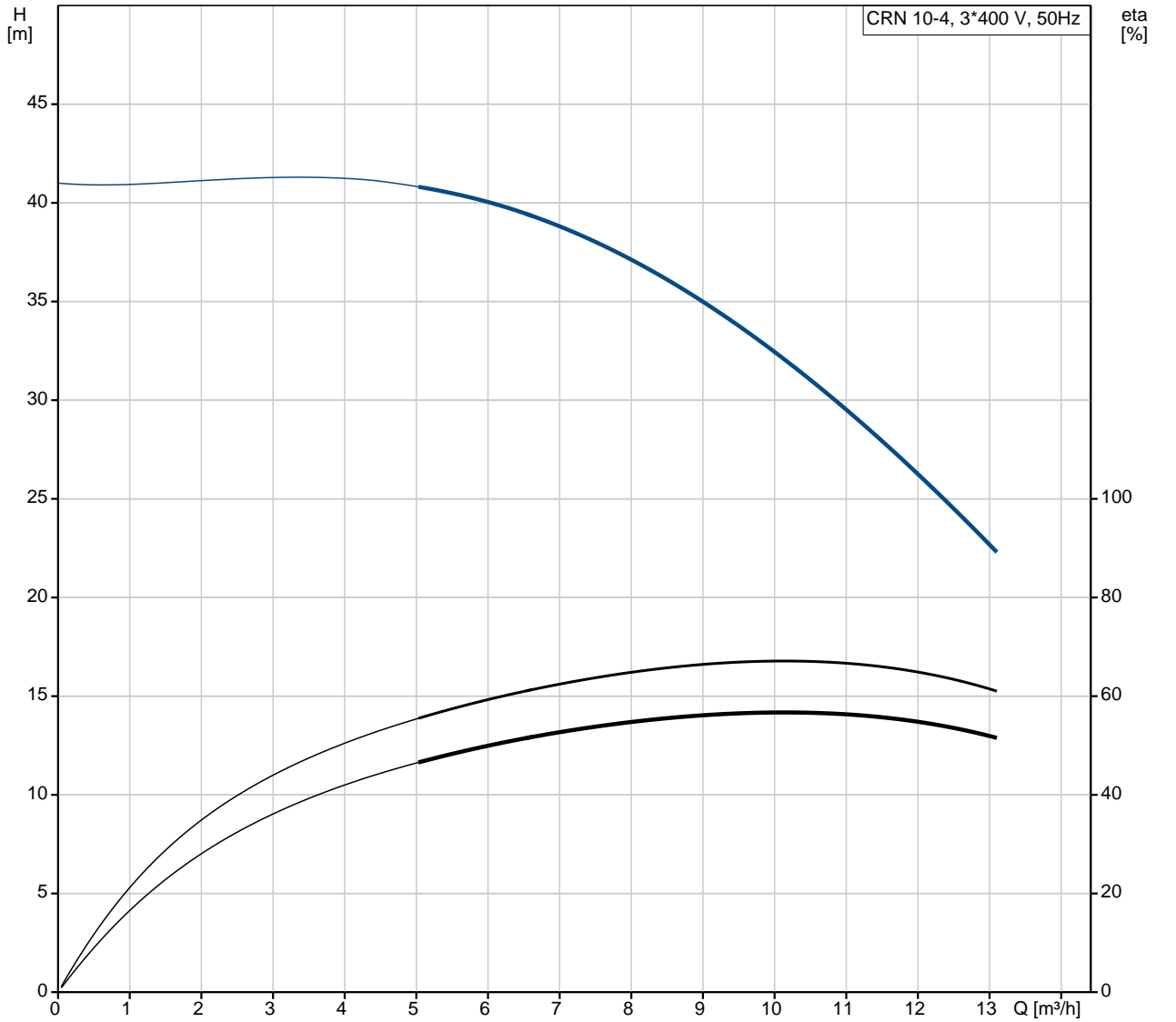

Description	Value
General information:	
Product name:	CRN 10-4 A-FGJ-H-E-HQQE
Product No:	96527743
EAN number:	5700397084830
Price:	1.740,00 GBP
Technical:	
Pump speed on which pump data are based:	2896 rpm
Rated flow:	10 m ³ /h
Rated head:	31.9 m
Head max:	40.8 m
Stages:	4
Impellers:	4
Number of reduced-diameter impellers:	0
Low NPSH:	N
Pump orientation:	Vertical
Shaft seal arrangement:	Single
Code for shaft seal:	HQQE
Approvals on nameplate:	CE, EAC, ACS
Curve tolerance:	ISO9906:2012 3B
Pump version:	A
Model:	A
Materials:	
Base:	Stainless steel EN 1.4408 AISI 316
Impeller:	Stainless steel EN 1.4401 AISI 316
Material code:	H
Code for rubber:	E
Bearing:	SIC
Installation:	
Maximum ambient temperature:	60 °C
Maximum operating pressure:	25 bar
Max pressure at stated temp:	25 bar / 120 °C 25 bar / -20 °C
Type of connection:	DIN / ANSI / JIS
Size of inlet connection:	DN 40 1 1/2 inch
Size of outlet connection:	DN 40 1 1/2 inch
Pressure rating for pipe connection:	PN 25
Flange rating inlet:	300 lb
Flange size for motor:	FT115
Connect code:	FGJ
Liquid:	
Pumped liquid:	Water
Liquid temperature range:	-20 .. 120 °C
Liquid temperature during operation:	20 °C
Density:	998.2 kg/m ³
Electrical data:	
Motor standard:	IEC
Motor type:	90SB
IE Efficiency class:	IE3
Rated power - P2:	1.5 kW
Power (P2) required by pump:	1.5 kW
Mains frequency:	50 Hz

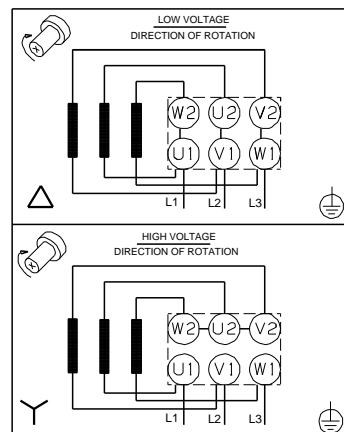
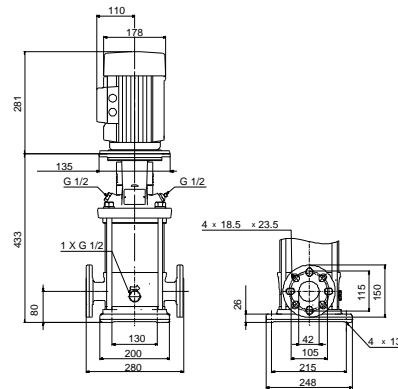
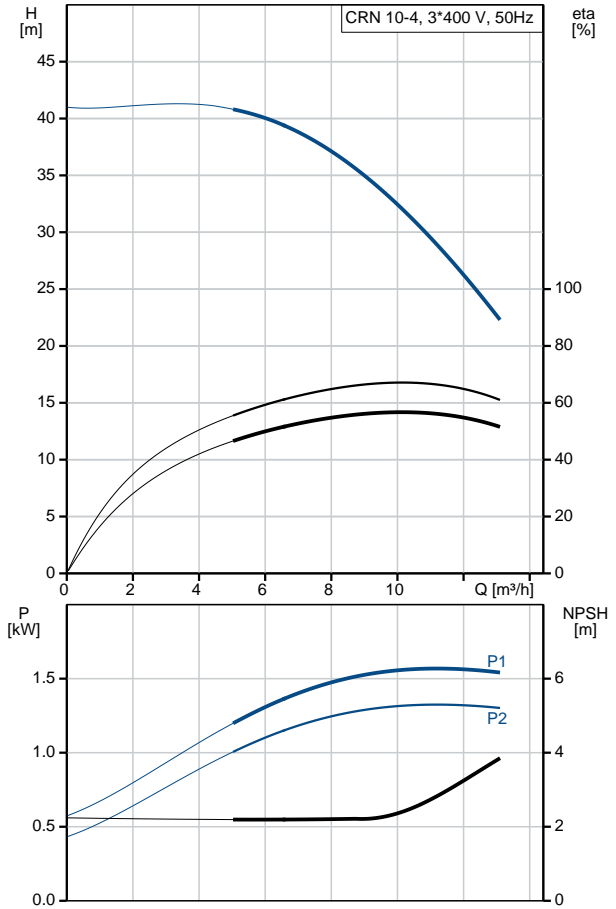



Company name:

Created by:

Phone:

Date:

12/03/2019

Description	Value
Rated voltage:	3 x 220-240D/380-415Y V
Rated current:	5.45/3.15 A
Starting current:	850-930 %
Cos phi - power factor:	0.87-0.82
Rated speed:	2890-2910 rpm
Efficiency:	IE3 84,2%
Motor efficiency at full load:	84.2 %
Motor efficiency at 3/4 load:	84.5 %
Motor efficiency at 1/2 load:	83.1 %
Number of poles:	2
Enclosure class (IEC 34-5):	55 Dust/Jetting
Insulation class (IEC 85):	F
Motor protec:	NONE
Motor No:	85U05906
Controls:	
Frequency converter:	NONE
Others:	
Minimum efficiency index, MEI $\hat{\alpha}\%$:	0.70
Net weight:	46 kg
Gross weight:	49 kg
Shipping volume:	0.094 m ³
Sales region:	Great Britain
Country of origin:	GB
Custom tariff no.:	84137075

96527743 CRN 10-4 A-FGJ-H-E-HQQE 50 Hz

